

730 Drive with 720R/RX Pumphead



700 series cased pump

Features and benefits

- Color display and intuitive menu structures provide visual status indication and minimal key presses
- Flow rates from 0.12 L/h (0.03 USGPH) to 3,300 L/h (872 USGPH)
- 3,600:1 speed control range from 0.1 to 360 rpm in 0.1 rpm increments
- Keypad incorporates 3-level security PIN lock
- IP66 (NEMA 4X) cased pumps
- Dual voltage 115/230 V 50/60 Hz
- Remote Analogue/Digital, RS485, PROFIBUS®, PROFINET®, SCADA and EtherNet/IP™ control options



730 Drive with 720R/RX Pumphead performance

720RX four-roller extension pumpheads for continuous 4.8 mm wall thickness tubing – Tube bore and flow rates – L/h (USGPH)										
720R/RX twin pumpheads	0.25 bar (3.6 psi)		0.5 bar (8 psi)		1 bar (15 psi)		1.5 bar (22 psi)		2 bar (30 psi)	
	Max speed (rpm)*	Max flow	Max speed (rpm)*	Max flow	Max speed (rpm)*	Max flow	Max speed (rpm)*	Max flow	Max speed (rpm)*	Max flow
9.6 mm (0.4")	300*	700 (185)	300*	700 (185)	300*	700 (185)	250	590 (156)	200	470 (124)
12.7 mm (0.5")	300*	1300 (343)	300*	1300 (343)	250	1100 (291)	200	870 (230)	175	760 (201)
15.9 mm (0.6")	300*	1800 (476)	200	1200 (317)	175	1100 (291)				
19.0 mm (0.7")	300*	2500 (660)	200	1700 (449)	160	1390 (367)				
25.4 mm (1.0")	300*	3300 (872)	200	2200 (581)						

*The maximum speed is reduced at increased discharge pressures to ensure safe running of the pump

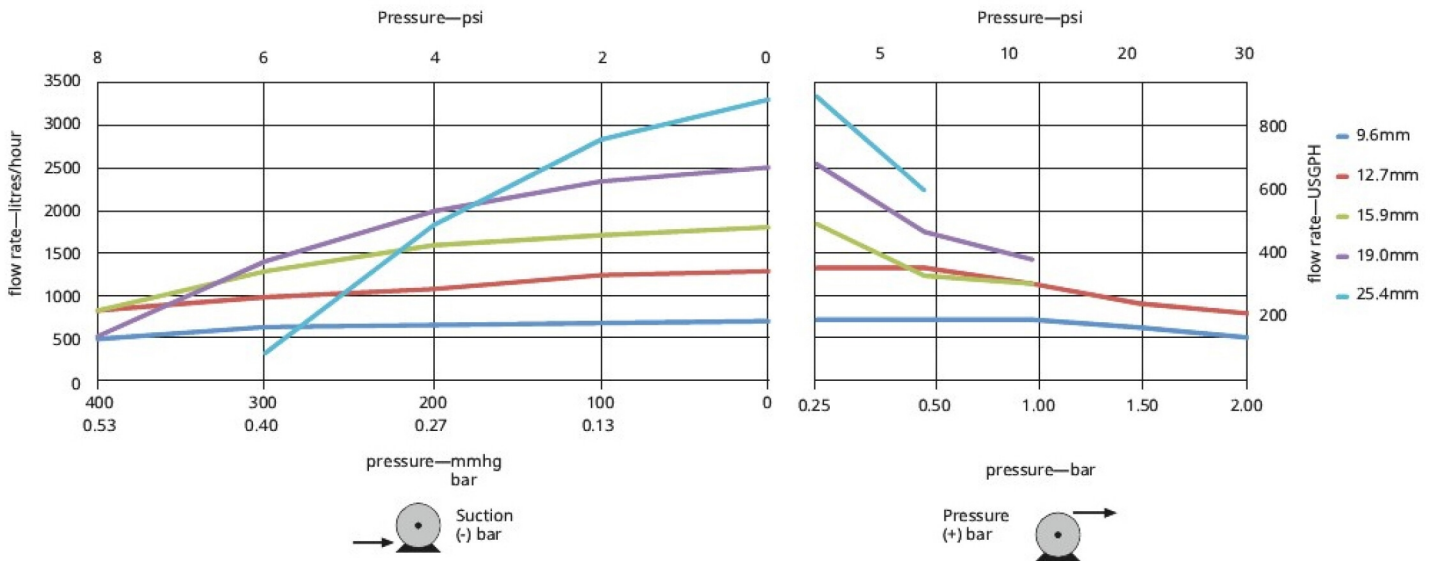

Technical specifications

	730 Drive with 720R/RX Pumphead
Pumphead number of rollers	4
Pumphead number of channels	1
FlowRateRange	0.12 L/h to 3300 L/h
FlowRateRange	0.03 USGPH to 872 USGPH
Drive speed control ratio	3600:1
Drive speed	0.1 - 360 rpm
Operating temperature	40 °F to 104 °F (5 °C to 40 °C)
Weight	69.4 lbs (31.5 kg)
Drive weight	40.8 lbs (18.5 kg)
Control types	EtherNet/IP™, PROFIBUS®, PROFINET®, Remote Analogue/Digital, RS485, SCADA
Drive control options	DuN, DuS, EnN, PnN, SN, UN, US
Standards	CE, cETLus, C-Tick, IRAM, NSF/ANSI 61 (for Marprene tubing and loadsure elements)
Drive ingress protection	IP66, NEMA 4X
Drive humidity	(Non-condensing) 80% up to 31°C (88°F), decreasing linearly to 50% at 40C (104F)
Drive noise	85dB(A) at 1m
Max. altitude	6562 ft (2000 m)
Drive power supply	100 to 120 V/200 to 240 V 1ph 50/60 Hz 350 VA, 100 V to 120 V/200 V to 240 V 1ph 50/60 Hz 350 VA
Compatible tubing bore size	9.6, 12.7, 15.9, 19, 25.4 mm
Compatible tubing wall thickness	4.8 mm

Materials of construction

	730 Drive with 720R/RX Pumphead
Driveshaft	Stainless steel 440C
Drive casework	Pressure die-cast aluminum LM24, Pressure die-cast aluminum LM6
Drive casework coating	Alocrom pre-treatment, Exterior grade polyester powder coat
Guide roller assembly	MoS2 filled Nylon 6 (Nylatron)
Drive keypad/HMI	Polyester
Pumphead front back plates	Aluminum
Drive rear blanking plate	Stainless steel 316
Pumphead body assembly	Aluminum
Pumphead roller assembly	MoS2 filled Nylon 6 (Nylatron)
Pumphead rotor assembly	Aluminum, Stainless steel
Pumphead track	Aluminum
Spindles	Stainless steel
Springs	Stainless steel
Switch-plate	ABS PA-765

Information listed covers the complete range.

For detailed specifications of individual models/components refer to user manual or contact WMFTS representative.

730 Drive with 720R/RX Pumphead dimensions

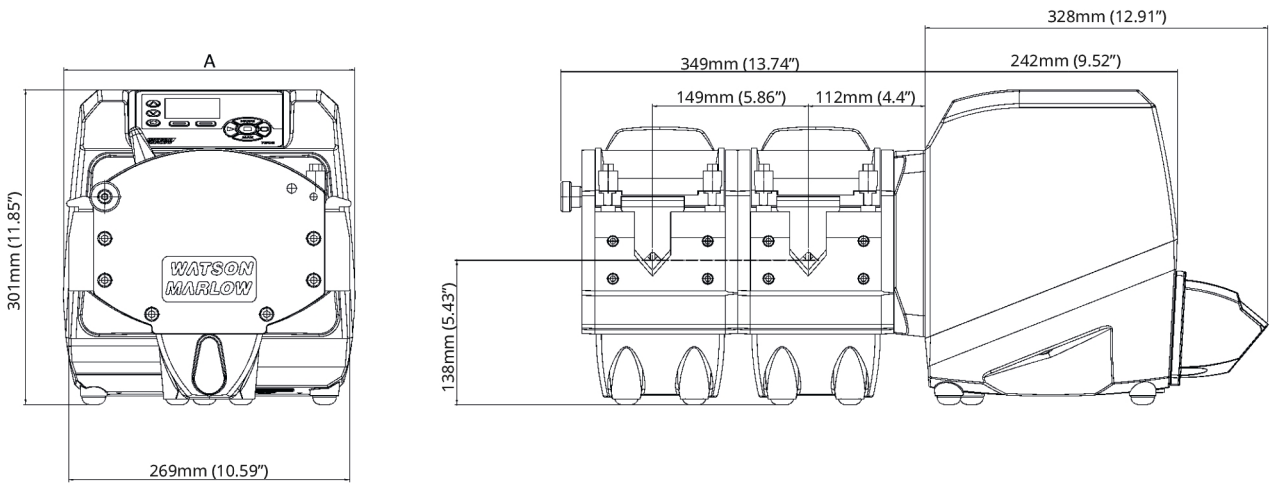

Dimension A	
720RX	279 mm (11")

Control options

Key to pump drive models									
730SN	730UN	730DuN	730BpN	730US	730DuS	730EnN	730PnN		
Standard IP66 / NEMA 4X	Universal IP66 / NEMA 4X	Digital Universal IP66 / NEMA 4X	Bus Pump / Profibus IP66 / NEMA 4X	Universal SCADA / IP66 / NEMA 4X	Digital Universal SCADA / IP66 / NEMA 4X	EtherNet/IP / IP66 / NEMA 4X	PROFINET® / IP66 / NEMA 4X		
Manual control									
Pump drives	730SN	730UN	730DuN	730BpN	730US	730DuS	730EnN	730PnN	
Intuitive keypad and colour display	✓	✓	✓	✓	✓	✓	✓	✓	✓
Choice of flowrate or speed display	✓	✓	✓	✓	✓	✓	✓	✓	✓
Full calibration with choice of flow units	✓	✓	✓	✓	✓	✓	✓	✓	✓
MemoDose function	✓	✓	✓	✓	✓	✓	✓	✓	✓
Auto restart facility	✓	✓	✓	✓	✓	✓	✓	✓	✓
Guard switch detection	✓	✓	✓	✓	✓	✓	✓	✓	✓
Leak detection		✓	✓	✓	✓	✓	✓	✓	✓
Dipensing (Network Control)									
Remote control									
Pump drives	730SN	730UN	730DuN	730BpN	730US	730DuS	730EnN	730PnN	
Configurable Start/Stop and leak detector, via contact closure or 5V TTL or 24V industrial logic**		✓	✓				✓		✓
Configurable start/stop, leak detector and pressure switch input (via 110 V industrial logic)						✓	✓		
Direction change and auto/manual toggle input (via contact closure or 5 V TTL to 24 V)		✓	✓						
Direction change and auto/manual toggle input (via 110 V industrial logic)						✓	✓		
Remote operation of MemoDose (foot/hand-switch or logic input)			✓	✓		✓	✓		
Four configurable digital status outputs through 24 V, 30 W relays			✓	✓					
Four configurable digital status outputs through 110 V relays						✓	✓		
Remote pressure/flow sensors								✓	✓
Analogue speed control									
Pump drives	730SN	730UN	730DuN	730BpN	730US	730DuS	730EnN	730PnN	
Fully configurable inputs; 0-10 V or 4-20 mA		✓	✓			✓	✓		
Analogue outputs; 0-10 V, 4-20 mA		✓	✓			✓	✓		
Keypad/analogue input scaling (replacement of diaphragm pumps)			✓				✓		
Tacho frequency output; 0-1478 Hz		✓	✓						
2x sensor inputs 4-20 mA or 0-1000Hz*								✓	✓
Security									
Pump drives	730SN	730UN	730DuN	730BpN	730US	730DuS	730EnN	730PnN	
3-level security PIN lock	✓	✓	✓	✓	✓	✓	✓	✓	✓
Network communication									
Pump drives	730SN	730UN	730DuN	730BpN	730US	730DuS	730EnN	730PnN	
RS485 network control			✓			✓			
Digital pump commands (Profibus / EtherNet/IP)									
Pump drives	730SN	730UN	730DuN	730BpN	730US	730DuS	730EnN	730PnN	
PROFIBUS® DP V0				✓					
PROFINET® (CC-B & Netload Class III)									✓
EtherNet/IP™							✓		
Communication speeds from 9.6 kbits/s up to 12000 kbits/s					✓				
Network speed: 10/100 Mbps - Full Duplex Operation							✓		
Network speed: 100 Mbps - Full Duplex Operation									✓
Auto-detect bus speed				✓					
Speed set point				✓			✓		✓
Speed feedback				✓			✓		✓
Flow calibration function				✓			✓		✓
Hours run				✓			✓		✓
Revolution counter				✓			✓		✓
Leak detection				✓			✓		✓
Low fluid level alarm				✓			✓		✓
Diagnostic feedback				✓			✓		✓
Flow Totaliser							✓		✓
Sensor scaling							✓		✓
Dipensing (Network Control)								✓	✓

*Range of 3rd party pressure/flow sensors supported—see compatible sensor list on www.wmfts.com/literature

**If you can't see the option you need, contact the engineered products team at WMFTS to discuss

Product codes

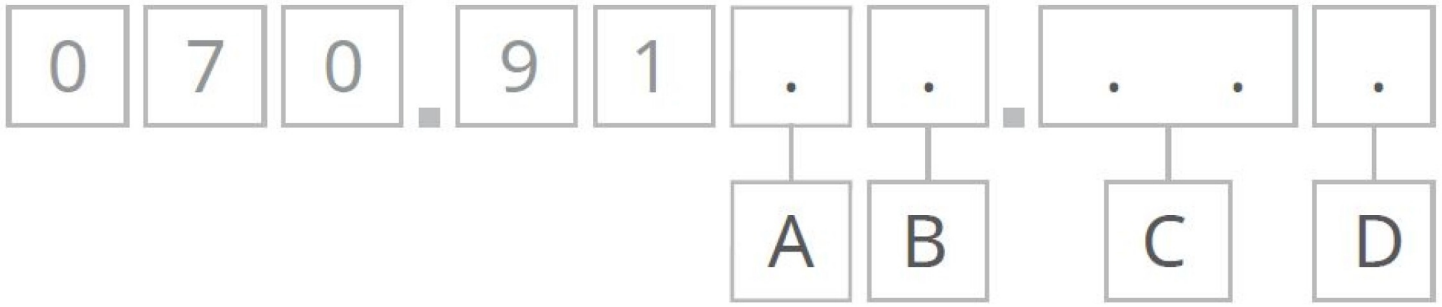

A	B	C	D
Model	Ingress Protection	Pumphead	Plug options
3: S	N: IP66/ NEMA 4X	00: 720R	U: UK mains plug
4: U	S: SCADA IP66/ NEMA 4X ^{1,2}	E0: 720RE	E: EU mains plug
5: Du		X0: 720R/RX	A: American mains plug
6: Bp		EX: 720RE/RX	K: Australia mains plug
8: En			R: Argentina mains plug
9: Pn			C: Swiss mains plug
			D: India/ South Africa mains plug
			B: Brazilian mains plug
Notes: 1. U and Du models only 2. Only available with American mains plug			

Disclaimer: All flow rates shown were obtained pumping water at 20 °C (68 °F) with zero suction and delivery heads. The information contained in this document is believed to be correct but Watson-Marlow Limited accepts no liability for any errors it contains and reserves the right to alter specifications without notice. It is the users responsibility to ensure product suitability for use within their application. Watson-Marlow, LoadSure, Pumpsil, PureWeld XL, Bioprene, Marprene are registered trademarks of Watson-Marlow Limited. Tri-Clamp is a registered trademark of Alfa Laval Corporate AB. GORE and STA-PURE are registered trademarks of W.L. Gore and Associates. Please state the product code when ordering pumps and tubing.



wmfts.com/global
28 October 2025