

Insulate valves

Insulate valves

Features and benefits

- Patented radial diaphragm, eliminates entrapment for easy cleaning
- Use with freeze tanks or any tank that has a critical temperature control mission
- Extended body and diaphragm allows for direct welding of vessel jacket
- Simple Tri-Clamp assembly makes maintenance 80 % faster
- Valve sizes: 0.5", 1.0", 1.5", 2.0", 2.5", 3.0", 4.0"



Performance

Insulate valve flow rates		
Size	Cv at 0.07 bar (1 psi)	
inches	LPM	USGPM
1.50	180	48
2.00	272	72

Technical specifications

	Insulate valves
Mounting type	Flush
Flow rate	180 - 272 l/m
Flow rate	48 - 72 USGPM
Sizes	1.5", 2.0", 3.0"
Outlet connections	Hygienic clamp, Tube end
Max. operating pressure	250 psi (17 bar)
Operating temperature	-60 °F to 350 °F (-51 °C to 177 °C)
Compatible actuators	Compact pneumatic, Fail closed, Fail open, Manual
Compatible diaphragms	EPDM, Silicone, Silicone plus
Surface finish options	Electropolished, Max 10 micro-inch Ra (0.25 µm Ra), Max 15 micro-inch Ra (0.375 µm Ra), Max 20 micro-inch Ra (0.5 µm Ra)
Certification and compliance	ISO 9001
Standards	ASME BPE, CE-PED
Weight	4.65 - 15.75 lbs (2.1 - 7.2 kg)

<p>Temperature range depends on diaphragm material.</p>

Materials of construction

	Insulate valves
Material	Hastelloy, Stainless steel 316L, Stainless steel AL-6XN

Insulate valves dimensions

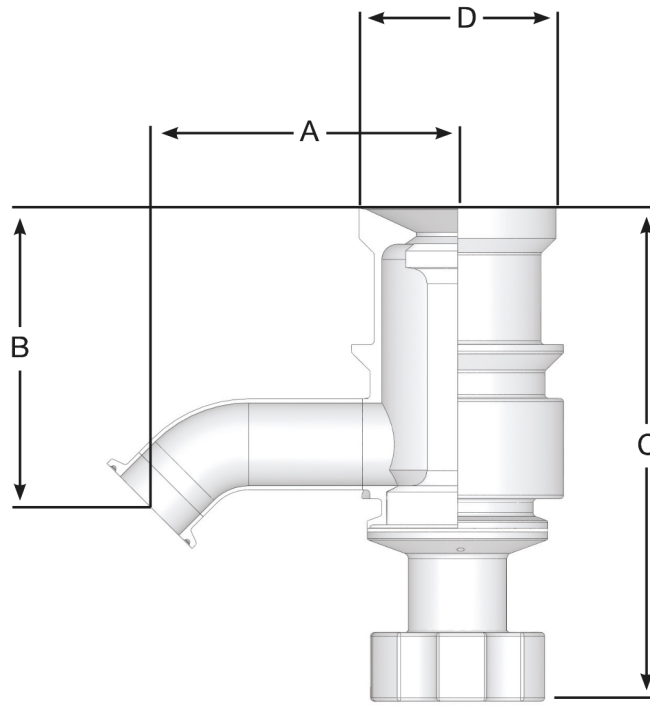

TEXX-100-X: Insulate valve										
Size	A		B		C - with Manual Actuator		C - with Pneumatic Actuator		D	
inches	mm	in	mm	in	mm	in	mm	in	mm	in
1.50	129.3	5.09	124.7	4.91	206.8	8.14	246.6	9.71	82.6	3.25
2.00	161.5	6.36	158.0	6.22	268.7	10.58	289.6	11.40	119.6	4.71

Weights

Weights							
Size	Valve Body		Total Weight with Manual Actuator		Total Weight with Pneumatic Actuator		
inches	kg	lb	kg	lb	kg	lb	
1.50	2.1	4.65	5.3	11.70	6.1	13.50	
2.00	7.2	15.75	10.5	23.10	11.3	24.90	

Product codes

Model Code	Part Description
TE17-100-X*	Extended Radial valve, 1.5" Flush Tank EN 1.4435 body/EN1.4404 fittings, 1.5" 45 clamp-end outlet, Flush diaphragm, Ra surface finish*, electropolished and passivated, includes body/actuator clamp
TE20-100-X*	Extended Radial valve, 2" Flush Tank EN 1.4435 body/EN1.4404 fittings, 2" 45 clamp-end outlet, Flush diaphragm, Ra surface finish*, electropolished and passivated, includes body/actuator clamp
TE30-100-X*	Extended Radial valve, 3" Flush Tank EN 1.4435 body/EN1.4404 fittings, 3" 45 clamp-end outlet, Flush diaphragm, Ra surface finish, electropolished and passivated, includes body/actuator clamp

*Note: X represents one of the following options- 1 = 20 micro-inch Ra surface finish 2 = 15 micro-inch Ra surface finish 3 = 10 micro-inch Ra surface finish

Disclaimer: The information contained in this document is believed to be correct but ASEPCO accepts no liability for any errors it contains and reserves the right to alter specifications without notice. It is the users responsibility to ensure product suitability for use within their application. Radial diaphragm is a trademark of ASEPCO Corporation. Tri-Clamp is a registered trademark of Alfa Laval Corporate AB. A member of Watson-Marlow Fluid Technology Group, A Spirax-Sarco Engineering plc company.



wmfts.com/global
14 July 2025