

300 VBM heavy duty pump



300 series panel mount pumps

Key Features

- Rugged peristaltic pumps for industrial applications
- Heavy duty spur gearbox with ball bearings
- Iconic flip-top design for fast and error-free tube loading
- Available with 313X extension pumpheads for multi-channel applications
- Flow rates up to 1800 ml/min

300 VBM heavy duty pump performance

313/314 VBM pumps – Flow rates (ml/min)			
Tube bore (mm)	VBM 24VDC		
	Speed (rpm)		
	100	190	360
0.5	3.4	6.5	12
0.8	7.0	14	26
1.6	27	52	100
3.2	100	190	360
4.8	420	790	
6.4	360	685	1296
8.0	500	950	1800

314 flowrates are approximately 85 % of 313 flow rates

Marprene tubing 1.6 mm wall, zero pressure and no suction lift

Nominal flow rates may vary +/-10 %

Technical specifications

	300 VBM heavy duty pump
Motor types	Variable speed brushless DC motor
Pumphead options	313D, 314D
Pumphead number of rollers	3, 4
Pumphead number of channels	1
FlowRateRange	0.3 ml/min to 1800 ml/min
	4 rpm to 480
Supply voltage	24VDC
Operating temperature	23 °F to 104 °F (-10 °C to 40 °C)
Rated Power	60 W
Control options	0-4 V
Alarms	Cover-Open
Outputs	Tacho
Ingress Protection	IP41 drive
Gearbox ratio	Spur; 10:1, Spur; 20:1, Spur; 40:1, Spur; 5:1, Spur; 7.5:1
Compatible tubing bore size	0.5, 0.8, 1.6, 3.2, 4.8, 6.4, 8 mm
Compatible tubing wall thickness	1.6 mm

Outputs are for ADC version only. Alarms are for EtherNet/IP™ & PROFINET® versions only.

For detailed specifications of individual models refer to product reference manual or contact WMFTS representative.

Materials of construction

	300 VBM heavy duty pump
Pumphead body assembly	Glass filled polypropylene, Polyacrylamide–IXEF (PARA), Stainless steel
Pumphead rotor assembly	Electroless nickel plated hardened steel, Glass filled Nylon
Pumphead roller assembly	MoS2 filled Nylon 6 (Nylatron)

Information listed covers the complete range. For detailed specifications of individual models/components refer to product reference manual or contact WMFTS representative.

300 VBM heavy duty pump dimensions

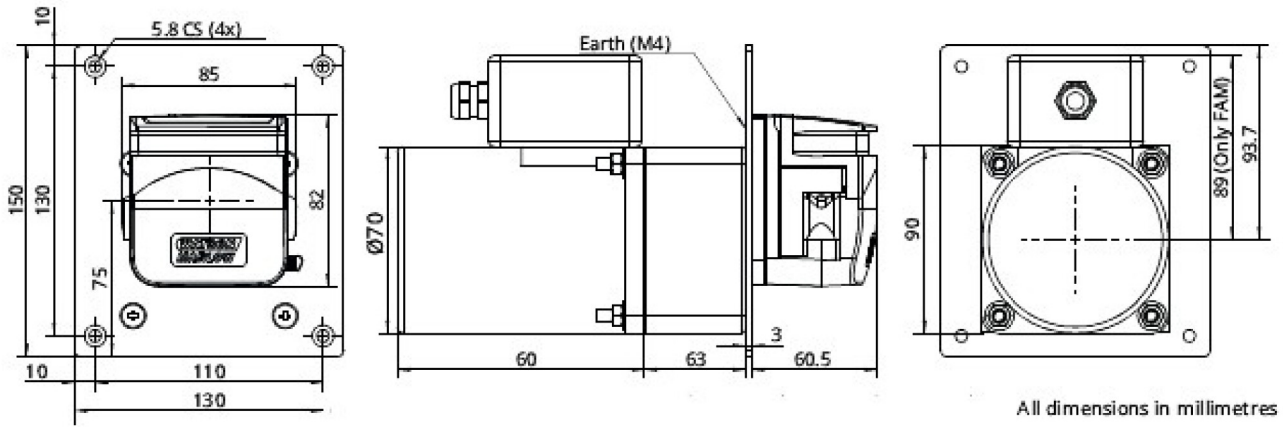

Product codes

Pump product codes				
Description	Supply voltage	Speed (rpm)	Number of channels	Product code
313VBM/D	24 VDC	100	3	040.NP23.010
	24 VDC	190	2	040.NS23.010
	24 VDC	360	1	040.NV23.010

Silicone 8.0 mm no backpressure

Marprene max 6.4 mm no backpressure

Disclaimer: All flow rates shown were obtained pumping water at 20 °C (68 °F) with zero suction and delivery heads. Watson-Marlow, Pumpsil, PureWeld XL, Bioprene and Marprene are trademarks of Watson-Marlow Limited. Disclaimer: The information contained in this document is believed to be correct but Watson-Marlow Limited accepts no liability for any errors it contains, and reserves the right to alter specifications without notice. GORE and STA-PURE are trademarks of W. L. Gore & Associates. Please state the product code when ordering pumps and tubing.



wmfts.com/global
21 October 2025