

# 825 series hygienic pump

800 series process pumps

## Features and benefits

- Maximum flow rate of 2060 L/h and pressures up to 3.5 Bar
- CIP/SIP sterilization at full velocity with no bypass required
- Self-priming and dry running, with no valves, seals or glands
- Door proximity sensor, to enable safe access during tube changes or cleaning
- Options for Bioprene and STA-PURE elements, to USP Class VI and hygienic stainless steel connectors certified to 3.1.B BS/EN 10204
- Ideal for viscous or shear sensitive products
- Motor/gearbox and control options include fixed speed, variable speed with mechanical variators, fixed speed motors with inverter control for 4 mA to 20 mA and 0 V to 10 V process control, remote stop/start and reverse and frequency output
- Pumpheads to accept B5 output flange-mounted gear motors in a range of single and three phase fixed and electronic variable speeds



## 825 series hygienic pump performance

### 825 series

Speed (rpm)	Flow rate (L/h)	Fitted Motor Power (kW)
8	162	0.37
10	196	0.37
13	260	0.55
17	327	0.55
21	412	0.55
26	507	0.55
28	563	0.55
33	658	0.55
36	721	0.55
40	796	0.55
47	933	0.75
53	1050	0.75
59	1169	0.75
67	1327	0.75
74	1474	1.1
84	1672	1.1
90	1787	1.1
104	2060	1.1

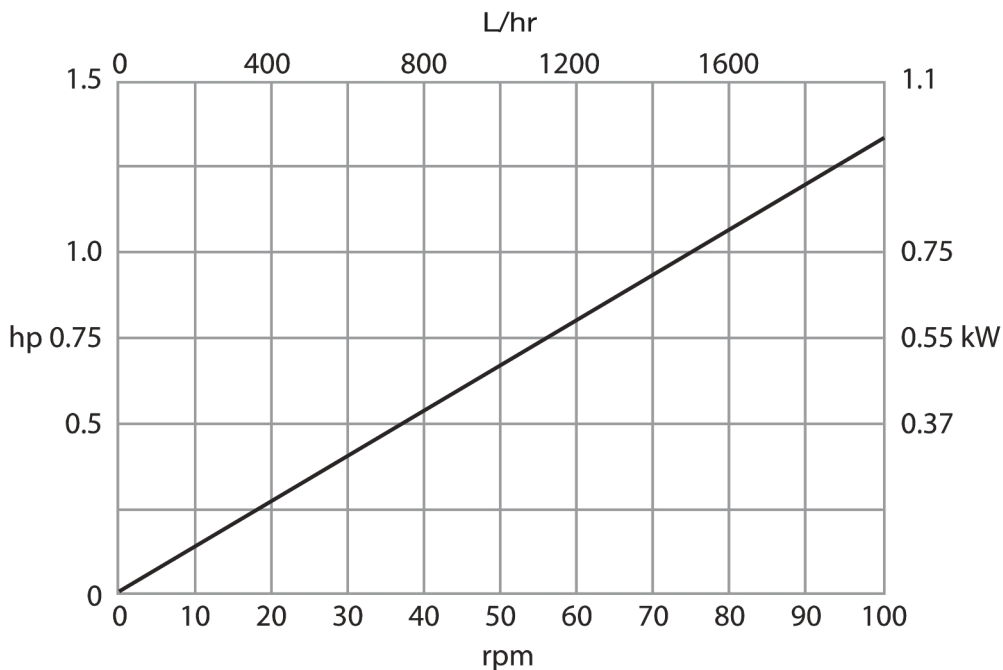

## Technical specifications

825 series hygienic pump	
FlowRateRange	162 L/h to 2060 L/h
Max. operating pressure	50.7 psi (3.5 bar)
Fluid temperature	-32 °F to 175 °F (0 °C to 80 °C)
Motor types	Fixed speed motor, Variable speed motor
	8 rpm to 104
Noise	<75dB(A) at 1m
Weight	187 lbs (85 kg)

## Materials of construction

825 series hygienic pump	
Fixings	Stainless steel, Zinc plated high tensile steel
Support frame	Stainless steel 304

## 825 series hygienic pump dimensions

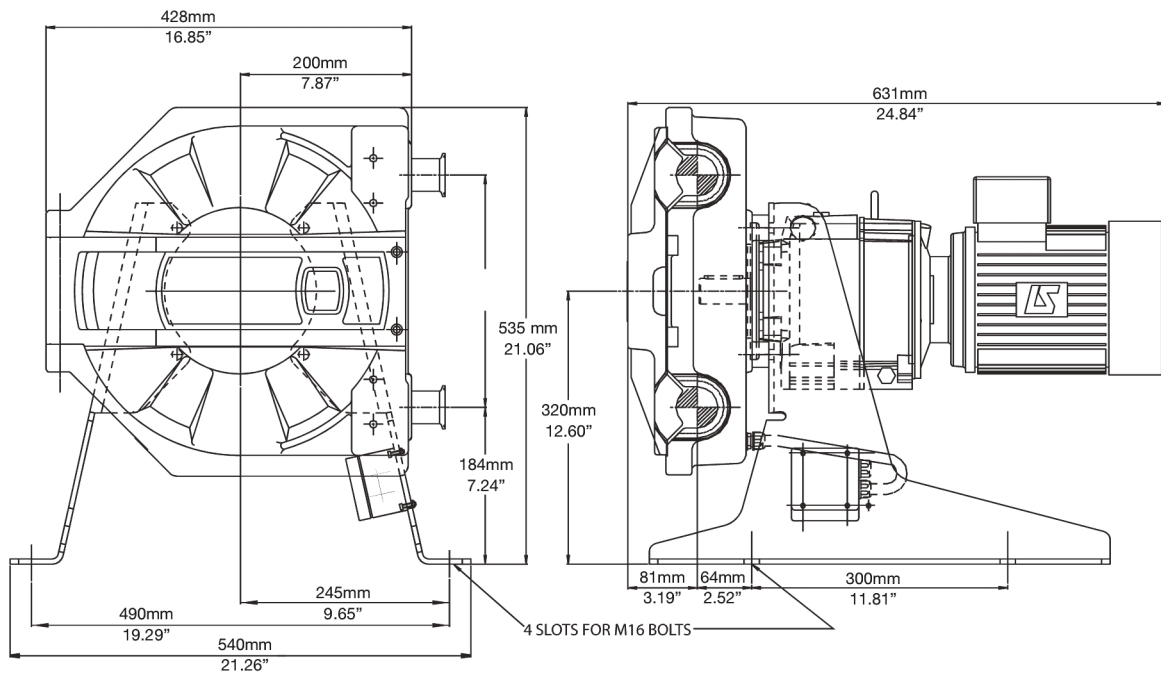

Disclaimer: All flow rates shown were obtained pumping water at 20 °C (68 °F) with zero suction and delivery heads. Watson-Marlow, Pumpsil, PureWeld XL, Bioprene and Marprene are trademarks of Watson-Marlow Limited. Disclaimer: The information contained in this document is believed to be correct but Watson-Marlow Limited accepts no liability for any errors it contains, and reserves the right to alter specifications without notice. GORE and STA-PURE are trademarks of W. L. Gore & Associates. Please state the product code when ordering pumps and tubing.



wmfts.com/global  
10 July 2025