

Certa Plus 400

Certa Plus process pump

Features and benefits

- Gentle product handling preserves high quality of product
- Impressive suction capability
- Almost zero pulsation
- Outstanding energy efficient pumping principle
- Bi-directional running
- Only one shaft and one seal system
- Different port orientations available, including self-draining position
- Traceability back to base materials



Certa Plus 400 performance

Performance curves

These performance curves show the theoretical flow without consideration of slip

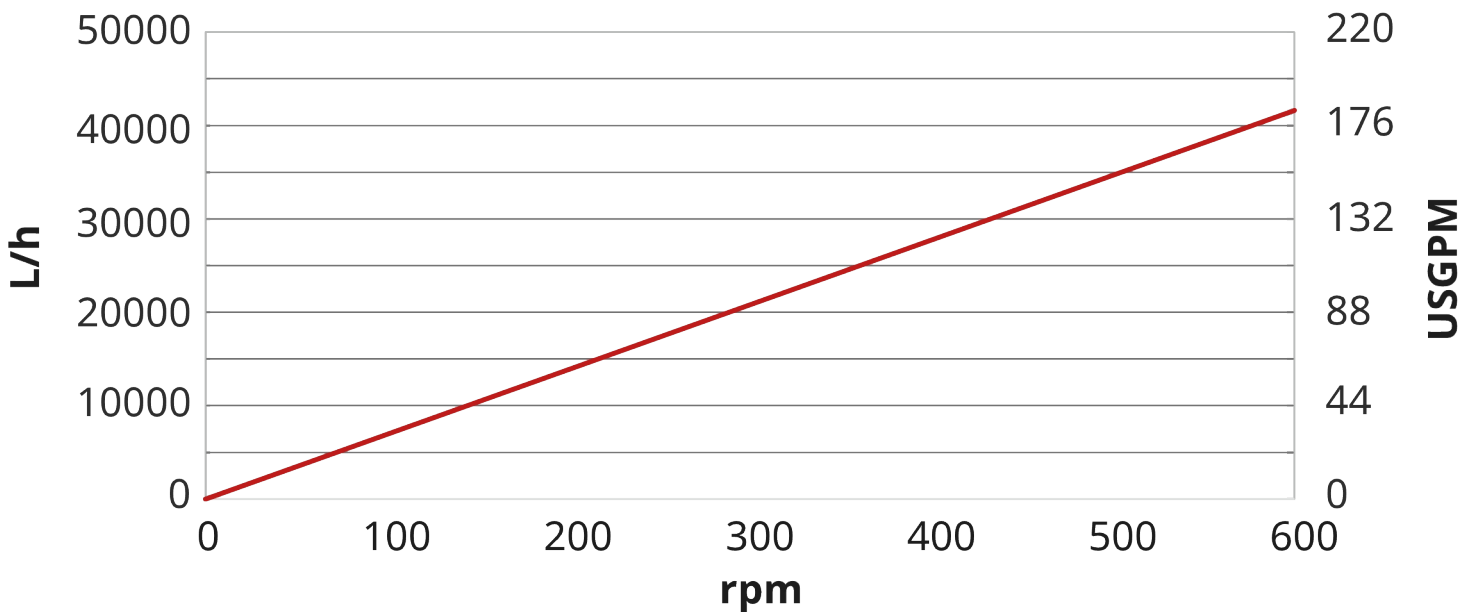

Technical specifications

	Certa Plus 400
Volume per revolution	1.16 l (0.305 USG)
Max. particle size	38 mm (1.5 in)
Suction pressure	85% of a vacuum
Max. operating pressure	6 bar (87 psi)
Operating temperature	-20 °C to 100 °C (-4 °F to 212 °F)
Max. SIP temperature	121 °C (250 °F)
Standards	3-A, ATEX, EHEDG Type EI Class I, EHEDG Type EL Class I Aseptic
Certification and compliance	EC 1935/2004, FDA, USP Class VI
Port orientation	Various options to meet your requirements
Port type	Flange, Milk fitting, RJT, SMS, TC
Shaft diameter	50 mm (1.97 in)
Shaft height	200 mm (7.87 in)

Materials of construction

	Certa Plus 400
Housing	Stainless steel 1.4435, Stainless steel 316L
Bearing frame	Stainless steel 1.4301, Stainless steel 304
Rotor	Stainless steel 1.4435, Stainless steel 316L
Gate	PEEK, PTFE
Seals/gaskets	EPDM, FKM
Shaft seal	PTFE, SSIC

Certa Plus 400 dimensions

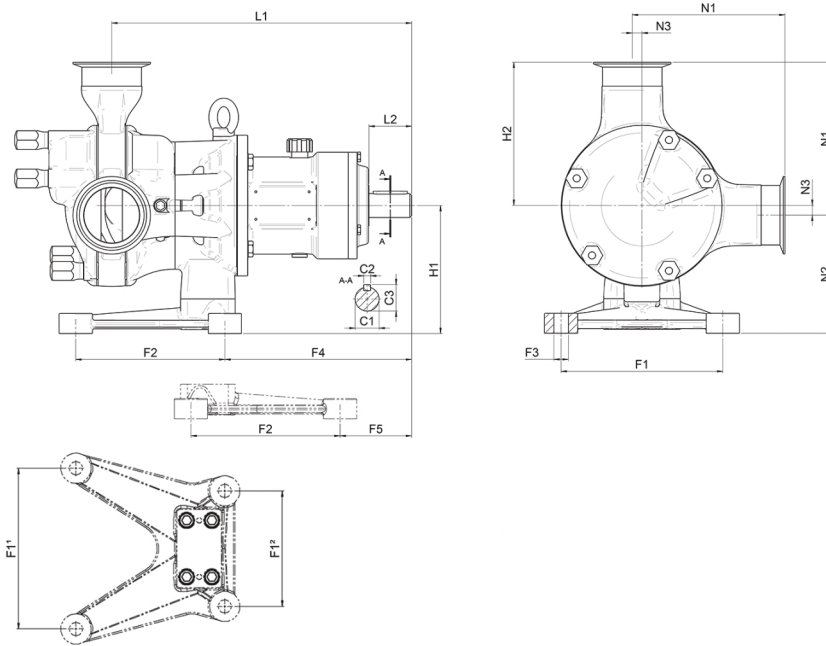

Model	Nozzles						Foot					Length				Height				Coupling										
	N1		N2		N3		F1		F2		F3		F4		F5		L1		L2		H1		H2		C1		C2		C3	
	mm	in.	mm	in.	mm	in.	mm	in.	mm	in.	mm	in.	mm	in.	mm	in.	mm	in.	mm	in.	mm	in.	mm	in.	mm	in.	mm	in.	mm	in.
C400	323.5	12.74	169	6.65	31	1.22	266.5	10.49	254	10.00	Ø21	Ø0.83	301	11.85	169	6.65	513.5	20.22	77	3.03	200	7.87	292.5	11.52	Ø50	Ø1.97	14	0.55	53.5	2.11

Disclaimer: All flow rates shown were obtained pumping water at 20 °C (68 °F) with zero suction and delivery heads. Disclaimer: The information contained in this document is believed to be correct but Watson-Marlow Limited accepts no liability for any errors it contains and reserves the right to alter specifications without notice. Watson-Marlow, MasoSine, Qdos, ReNu, LoadSure, Bioprene, Pumpsil and Marprene are trademarks of Watson-Marlow Limited. STA-PURE PFL® and STA-PURE PCS® are registered trademarks of W.L Gore & Associates Inc. Please state the product code when ordering pumps and tubing.



wmfts.com/global
28 October 2025