

FC32

Table top screw capping machines

Features and benefits

- Designed for small batch production
- Provides consistent closure torque for screw-threaded bottle capping
- Protect operators from repetitive strain injuries caused by manual capping
- Suitable for wide range of caps and bottles
- Easy adjustment and change-over between bottles or caps
- Compact footprint to fit inside BSC or LAF

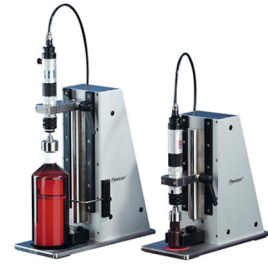

Technical specifications

	FC32
Ingress Protection	IP31
Torque rating	Black spring 1.0-4.0 Nm; Yellow spring 0.9-1.8 Nm; Green spring 0.5-1.0 Nm; Red spring 0.3-0.5 Nm
Standards	DS/EN ISO 12100 DS/EN 60204 2006/42/EC 2006/95/EC 2004/108/EC
Sterilisation methods	Vaporised Hydrogen Peroxide (VHP) compatible
Power supply	110/230 V AC, 50/60 Hz
Power consumption	Max 50 W
Air supply	6 bar (87 PSI) to ISO 8573-1 2010 [1:4:2]
Weight	16 kg (35 lbs)
Packaged Weight	16.1 kg
Packaged Dimensions	74*51*30 cm
Accessories	Cap tools, bottle tools
Max. bottle/vial diameter	100 mm
Max. bottle/vial height	240 mm
Max Capacity	1000 units/hour

FC32 dimensions

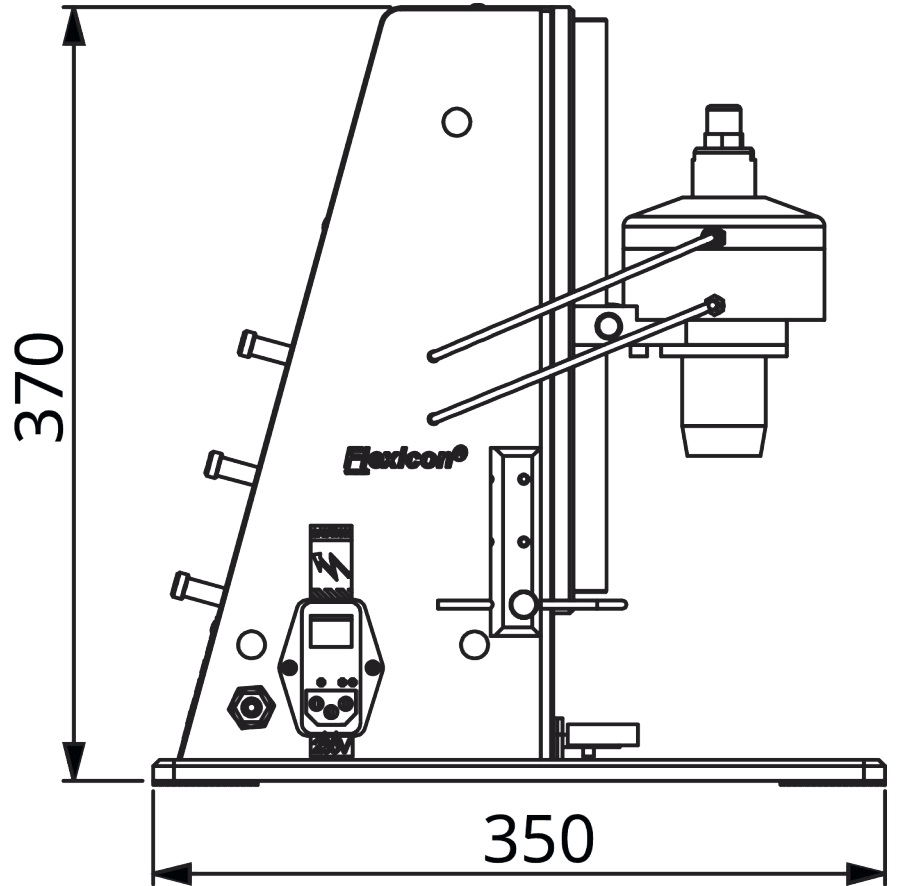
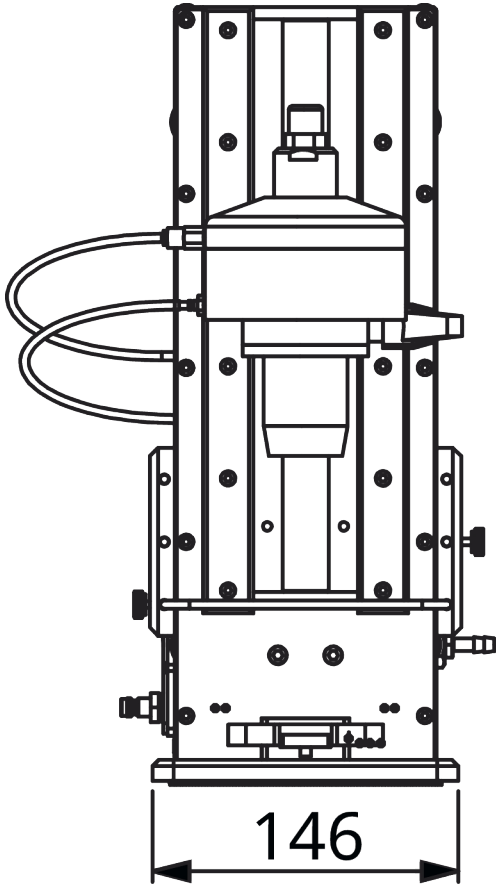

FS32

Units in mm

Disclaimer: The information in this document is believed to be correct, but Watson-Marlow Flexicon A/S accepts no liability for any errors it contains, and reserves the right to alter specifications without notice. WARNING: These products are not designed for use in, and should not be used for, patient-connected applications. WMArchitect and Accusil are registered trademarks.



wmfts.com/global
14 July 2025