

APEX20

APEX hose pumps

Bredel

Hose Pumps

Features and benefits

- Seal-less, valve-less design
- Precision machined hose elements for accurate, repeatable performance
- Optimized hose compression for unmatched flow stability
- Direct-coupled drive and maximum flexibility - no separate couplings to align or maintain
- Ultra compact design with flexibility to mount standard gear motors - rotor supported by own bearings to maximize gearbox life
- Lower maintenance costs - single component change means fewer spare parts inventory



APEX20 performance

Required motor power kW (hp)

APEX20

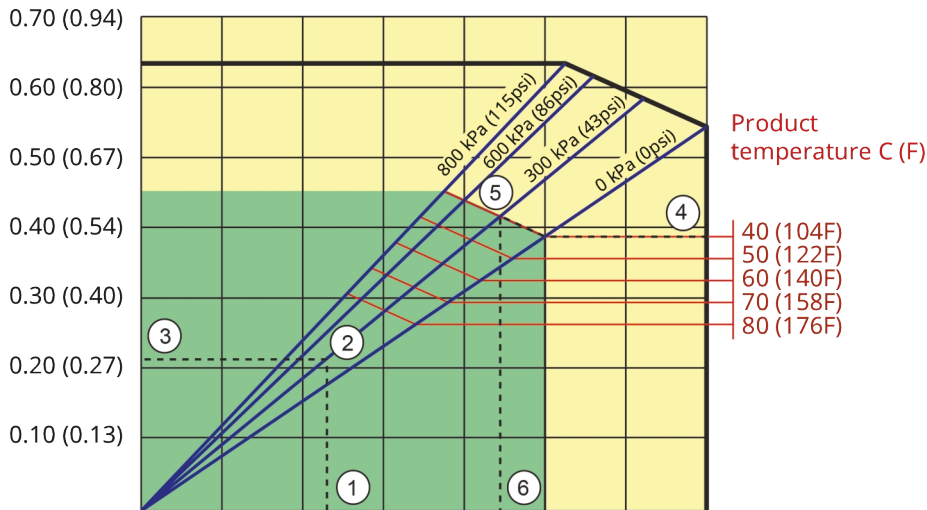

Pump speed rpm	20	40	60	80	100	120	140
Capacity L/h	175	350	525	700	875	1050	1225
Capacity USGPM	0.8	1.5	2.3	3.1	3.8	4.6	5.3

1. Flow required indicates pump speed
2. Calculated discharge pressure
3. Net motor power required
4. Product temperature
5. Calculated discharge pressure
6. Maximum recommended pump speed

- Continuous duty
- Intermittent duty

* Maximum 3 hours operation followed by minimum 1 hour stop

Technical specifications

	APEX20
Max. flow rate continuous	231 USGPH (875 L/h)
Max. flow rate intermittent	323 USGPH (1225 L/h)
Volume per revolution	0.038 USG (0.145 l)
Max. continuous operating speed	100 rpm
Max. intermittent operating speed	140 rpm
Max. operating pressure	116 psi (8 bar)
Suction pressure	0.05 bar abs
Suction pressure	0.73 psi abs
Max. inlet pressure	30 psi abs (2 bar abs)
Operating temperature	-4 °F to 113 °F (-20 °C to 45 °C)
Fluid temperature	-4 °F to 176 °F (-20 °C to 80 °C)
Min. starting torque	505 in.lbs (57 N m)
Weight	88 lbs (40 kg)
Port configurations	Down, Left, Right, Up
Compatible hose materials	CSM, EPDM, F-NBR, NBR, NBR for food, NR
Flange assembly type	ANSI, DIN

Materials of construction

	APEX20
Hose material	CSM, EPDM, F-NBR, NBR, NBR for food, NR
Housing	Die-cast aluminum (RAL 3011)
Rotor assembly	Cast iron
Cover assembly	Die-cast aluminum, EPDM, PMMA
Brackets and fasteners	Stainless steel 316
Support frame	Galvanized steel
Hose clamps	Stainless steel 316
Coupling bush	Alloy steel
Seals	EPDM, NBR

APEX20 dimensions

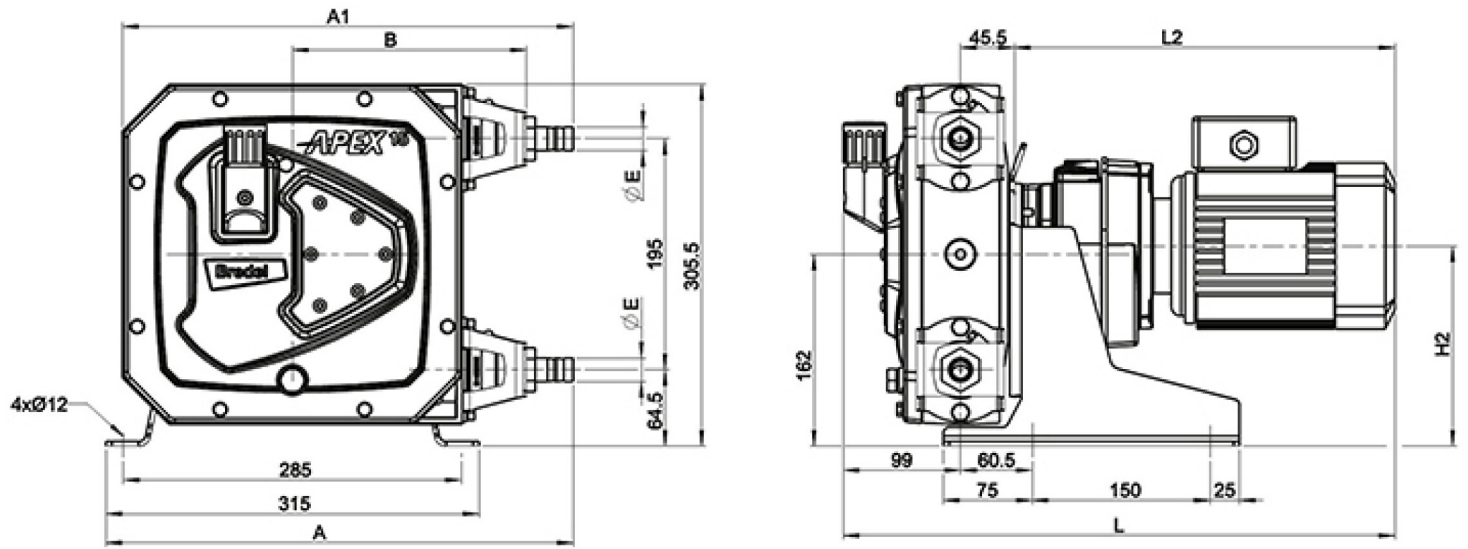

	A	A1	B	E	H2max	Lmax	L2max
APEX20 (mm)	394.5	380.5	197.5	Ø20	170	545.5	401
APEX20 (inches)	15.5	15	7.8	3/4" NPT	6.7	21.5	15.8
Connector sizes				MNPT	EN DIN	JIS	
APEX20				0.75"	20mm	20mm	

Product codes

Disclaimer: The information contained in this document is believed to be correct at the time of publication, but Watson-Marlow Bredel BV accepts no liability for any error it contains, and reserves the right to alter specifications without prior notice. All mentioned values in this document are values under controlled circumstances at our test bed. Actual flow rates achieved may vary because of changes in temperature, viscosity, inlet and discharge pressures and/or system configuration. APEX, DuCoNite, Bioprene and Bredel are registered trademarks.



wmfts.com/global
11 July 2025