

Bredel 25



Hose Pumps

Bredel hose pumps (10-50)

Features and benefits

- Dry running and self-priming
- Suction capability up to 9.5 mWC (374 inWC)
- No seals, ball-checks, diaphragms, glands, immersed rotors, stators or pistons to leak, clog, corrode or replace
- Handles abrasive slurries, corrosive acids, gaseous liquids
- No slippage, allowing true positive displacement for accurate and repeatable metering
- No ancillary equipment, check valves, sealing water flush systems or run-dry protection required
- Fully reversible to blow out suction and drain lines safely

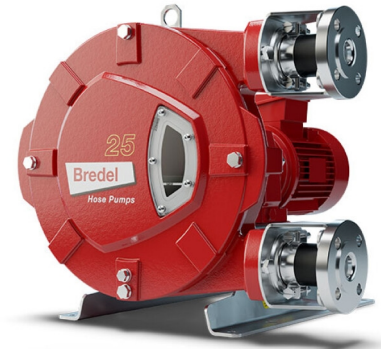

Bredel 25 performance

Required motor power kW (hp)

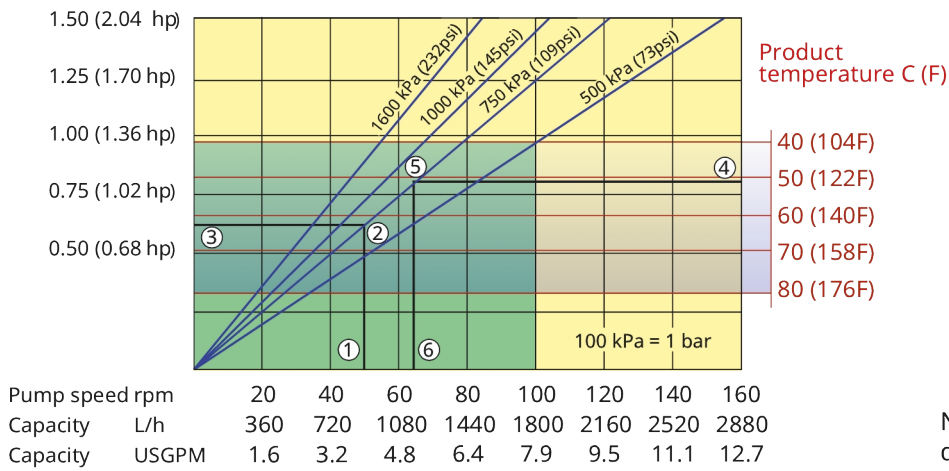

Note: The area of continuous operation diminishes with increased product temperatures. For product temperatures >40C, the area of continuous operation reduces to the corresponding red temperature line.

1. Flow required indicates pump speed
2. Calculated discharge pressure
3. Net motor power required
4. Product temperature
5. Calculated discharge pressure
6. Maximum recommended pump speed

- Continuous duty
- Intermittent duty

* Maximum 3 hours operation followed by minimum 1 hour stop

Technical specifications

	Bredel 25
Max. flow rate continuous	475 USGPH (1800 L/h)
Max. flow rate intermittent	723 USGPH (2740 L/h)
Volume per revolution	0.079 USG (0.3 l)
Max. continuous operating speed	100 rpm
Max. intermittent operating speed	155 rpm
Max. operating pressure	232 psi (16 bar)
Max. inlet pressure	51 psi abs (3.5 bar abs)
Max. suction capability	374 inWC (9.5 mWC)
Suction capability (80% Flow rate)	374 inWC (9.5 mWC)
Operating temperature	-4 °F to 113 °F (-20 °C to 45 °C)
Fluid temperature	-4 °F to 176 °F (-20 °C to 80 °C)
Min. starting torque	1018 in.lbs (115 N m)
Weight	198 lbs (90 kg)
Hose lubricant required	0.53 USG (2 l)
Port configurations	Down, Left, Right, Up
Compatible hose materials	CSM, EPDM, F-NBR, NBR, NBR for food, NR-Metering, NR-Transfer
Flange assembly type	ANSI, DIN, JIS

Please consult your Bredel representative for lower or higher temperature operation.

Allowable ambient temperature is based on pump capabilities and may be further limited by gearbox ambient capabilities.

Materials of construction

	Bredel 25
Hose material	CSM, EPDM, F-NBR, NBR, NBR for food, NR Endurance, NR-Transfer
Housing	Cast iron, ISO12944 category C4M
Rotor assembly	Cast iron, ISO12944 category C4M
Cover assembly	Cast iron, ISO12944 category C4M
Brackets and fasteners	Galvanized steel, Stainless steel 316
Support frame	Galvanized steel, Stainless steel 316
Hose clamps	Galvanized steel, Stainless steel 316
Seals	Nitrile

Bredel 25 dimensions

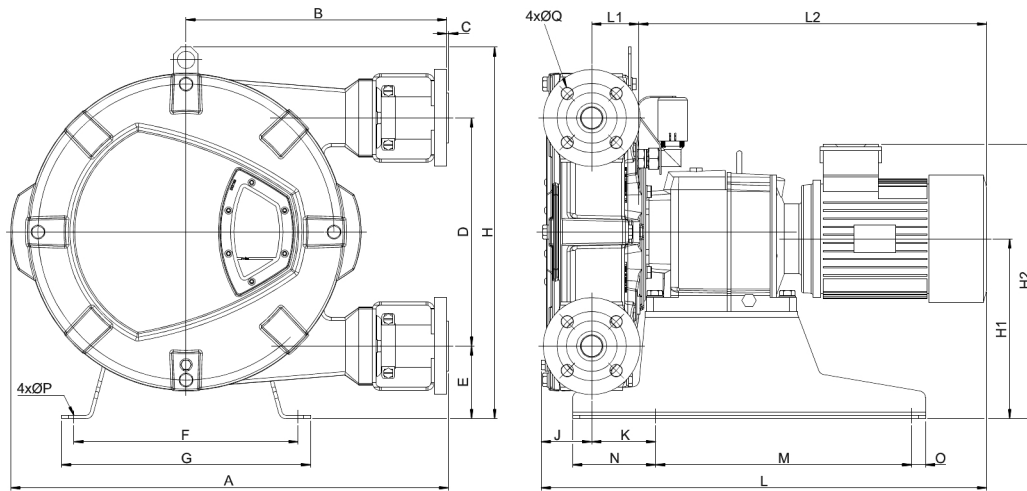

Type	A	B	C	D	E	F	G	H	H1	H2max	J	K	Lmax	L1	L2max	M	N	O	ØP	ØQ	R
Bredel 25 (mm)	521	304	2.5	264	98	279	315	460	222	359	66	97	592	58	468	305	120	15	12	14	85
Bredel 25 (inches)	20.5	12	0.09	10.4	3.9	11	12.4	18.1	8.7	14.1	2.6	3.8	23.3	2.3	18.4	12	4.7	0.6	0.47	0.6	3.3
Connector sizes								ANSI 150#					EN DIN					JIS			
Bredel 25								1"					25mm					25mm			

Product codes

Disclaimer: The information contained in this document is believed to be correct at the time of publication, but Watson-Marlow Bredel BV accepts no liability for any error it contains, and reserves the right to alter specifications without prior notice. All mentioned values in this document are values under controlled circumstances at our test bed. Actual flow rates achieved may vary because of changes in temperature, viscosity, inlet and discharge pressures and/or system configuration. APEX, DuCoNite, Bioprene and Bredel are registered trademarks.



wmfts.com/global
11 July 2025