

Bredel CIP25-32 Operating Manual

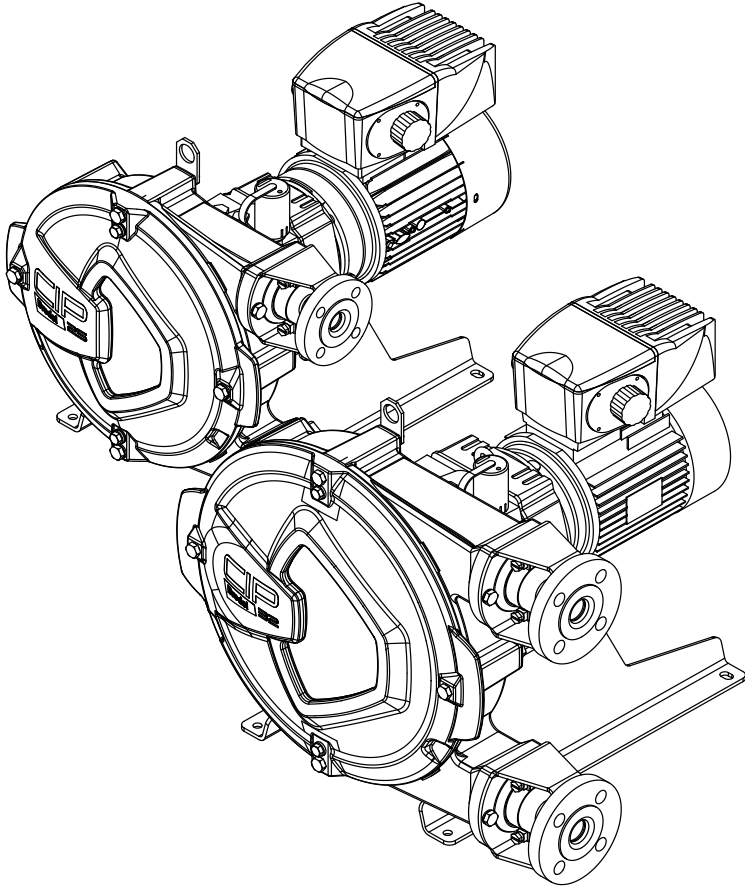

Contents

1 General	5
1.1 How to use this manual	5
1.2 Original instructions	5
1.3 Other supplied documentation	5
1.4 Service and support	5
1.5 Environment and disposal of waste	6
2 Safety	6
2.1 Symbols	6
2.2 Intended use	7
2.3 NSF/ANSI 61 certification	7
2.4 Responsibility	8
2.5 Qualification of the user	8
2.6 Regulations and instructions	8
3 Warranty conditions	9
4 Description	10
4.1 Identification of the product	10
4.2 Construction of the pump	14
4.3 Operation of the pump	15
4.4 Pump installation positions	16
4.5 Hose	17
4.6 Gearbox	19
4.7 Electric motor	19
4.8 Frequency controller	19
4.9 Available options	20
5 Installation	21
5.1 Unpacking and inspection	21
5.2 Installation conditions	21
5.3 Lifting and moving the pump	24
5.4 Placing the pump	24
6 Commissioning	27
6.1 Preparations	27
6.2 Commissioning	28

7 Operation	29
7.1 Temperature	29
7.2 Power rating	29
7.3 Performance graphs	29
7.4 Dry running	32
7.5 Hose failure	32
7.6 Fluid leakage	34
8 Maintenance	35
8.1 General	35
8.2 Maintenance and periodic inspections	35
8.3 Cleaning the hose	38
8.4 Changing lubricant	39
8.5 Changing oil in the gearbox	40
8.6 Changing the hose	40
8.7 Exchanging replacement parts	50
8.8 Adjust the compression force (shimming)	60
8.9 Fitting options	62
9 Storage	67
9.1 Hose pump	67
9.2 Hose	67
9.3 Lubricant	67
10 Troubleshooting	68
11 Specifications	76
11.1 Pumphead	76
11.2 Parts list	83
12 Safety form	93

Copyright

© 2025 Watson-Marlow Bredel B.V. All rights reserved.

The information provided herein may not be reproduced and/or published in any form, by print, photoprint, microfilm or any other means whatsoever (electronically or mechanically) without the prior written authorisation of Watson-Marlow Bredel B.V..

Names, trade names, brands, etc. used by Watson-Marlow Bredel B.V. may not, as per the legislation concerning the protection of trade names, be considered as available.

Disclaimers

The information contained in this document is believed to be correct but Watson-Marlow Bredel B.V. accepts no liability for any errors it contains and reserves the right to alter specifications without notice.

The information provided can be changed without prior notification. Watson-Marlow Bredel B.V. or one of its representatives cannot be held liable for possible damage resulting from use of this manual. This is an extensive limitation of the liability which applies to all damage, inclusive of (without limitation) compensating, direct, indirect or consequential damage, loss of data, income or profit, loss or damage to possessions and claims of third parties.

How to access an available translation

The following documents are available on the website. Enter www.wmfts.com/product-documents into your web browser or scan the QR code found on the pump nameplate:

- User manual
- Quick reference instructions for the replacement of the pump hose

Note: The replacement instructions are only for users that are familiar with the replacement procedures in the user manual.

System requirements

Source	Hardware	Software
Website	PC or tablet	Internet browser
		PDF reader
QR code	Smartphone or tablet with camera	Internet browser
		PDF reader
		App that can scan QR codes

How to use the QR code

1. Scan the QR code with your smartphone or tablet - The app forwards you to the webpage that contains the required language.
2. Open or save the user manual - The PDF reader program shows the selected user manual.

1 General

1.1 How to use this manual

This manual is intended as a reference book by means of which qualified users are able to install, commission and maintain the hose pump Bredel CIP25 and Bredel CIP32.

1.2 Original instructions

The original instructions for this manual have been written in English. Other language versions of this manual are a translation of the original instructions.

1.3 Other supplied documentation

Documentation of components such as the gearbox, the motor, and the frequency controller is not included in this manual. However, if additional documentation is supplied, you must follow the instructions in this additional documentation.

1.4 Service and support

Some specific adjustments, installation and maintenance or repair jobs fall beyond the scope of this manual. In case of doubt, consult your Bredel representative.

Make sure that you have the following data at hand:

- Serial number of the hose pump
- Part number of the pump hose
- Part number of the gearbox
- Part number of the electric motor
- Part number of the frequency controller

You will find these data on the identification plates or stickers on the pumphead, the pump hose, the gearbox, and the electric motor.

See also

Refer to "Description" on page 10

1.5 Environment and disposal of waste

Note: Always observe the local rules and regulations with respect to processing (non reusable) parts of the hose pump.



WARNING

Risk of poisoning and environmental damage. Pump parts can get contaminated by pumped liquids to such an extent that cleaning becomes insufficient. Dispose of contaminated parts according to local regulations.

When you discard items, obey these instructions:

- Use suitable personal protective equipment.
- Obey the safety instructions of the working environment.
- Obey the safety, health, and waste sorting instructions of the product.
- Drain, collect, and dispose of the lubricant in accordance with local rules and regulations.
- Collect and dispose of any leaking pumped liquid or oil in accordance with local rules and regulations.
- Neutralize residues of pumped liquid in the pump.
- Dispose of the parts in accordance with local rules and regulations.

Enquire within your local government about the possibilities for reuse or environment-friendly processing of packaging materials, (contaminated) lubricant, and oil.

2 Safety

2.1 Symbols

In this manual the following symbols are used:



WARNING

Procedures which, if not carried out with the necessary care, may result in serious bodily harm.



CAUTION

Procedures which, if not carried out with the necessary care, may result in serious damage to the hose pump, the surrounding area or the environment



Information on environmentally-friendly disposal or recycling of materials.

2.2 Intended use

The hose pump is exclusively designed for pumping suitable products. Every other or further use is not in conformance with the intended use. This is the use for which the technical product is intended in accordance with the specifications of the manufacturer, inclusive of his indications in the sales brochure. In case of doubt it is the use, which appears to be its intended use judging from the construction, execution and function of the product, and its description in the user's documentation.

Only use the pump in conformance with the intended use described above. The manufacturer cannot be held responsible for damage or harm resulting from use that is not in conformance with the intended use. If you want to change the application of your hose pump, contact your Bredel representative first.



WARNING

The pump is configured for use with specific fluids for which the chemical compatibility of the pump materials has been approved. Before using it in any application it is required to check the compatibility of the pump materials. Incompatible pumphead material, hose liner, hose connections and lubricant can lead to serious damage and safety hazards. Always contact your Bredel representative first.

The pumphead and drive mentioned in this manual is not suitable for use in a potentially explosive atmosphere. Contact your Bredel representative for information on Bredel pumps suitable for use in a potentially explosive atmosphere.

2.3 NSF/ANSI 61 certification

For specific combinations of the hose and insert and in combination with certain chemicals, the hose pumps are configured and delivered in compliance with NSF International certification NSF/ANSI Standard 61: Drinking Water System Components – Health Effects and will bear the NSF mark shown below. A list of certified products and relevant chemicals can be found at <http://www.nsf.org/certified-products-systems>. For further details refer to the Bredel User Guide NSF 61 certified hose pumps supplied with such a pump, which can also be found on the website, or contact your Bredel representative for advice.



Certified to
NSF/ANSI 61

2.4 Responsibility

The manufacturer does not accept any responsibility for damage or harm caused by not observing the safety regulations and instructions in this manual and other supplied documentation, or by negligence during installation, use, maintenance and repair of the hose pumps mentioned on the front cover. Depending on the specific working conditions or accessories used, additional safety instructions can be required.

Immediately contact your Bredel representative for advice if you notice a potential danger while using your hose pump.



WARNING

The user of the hose pump is fully responsible for observing local safety regulations and directives. Observe these safety regulations and directives when using the hose pump.

2.5 Qualification of the user

The installation, use and maintenance of the hose pump should only be performed by well-trained and qualified users. Temporary staff and persons in training may use the hose pump only under the supervision and responsibility of trained and qualified users.

2.6 Regulations and instructions

- Ensure this manual can be easily accessed for safe operation and maintenance.
- Everyone who works with the hose pump must be aware of the contents of this manual and observe the instructions with great care.
- Never change the order of the actions to be carried out.

3 Warranty conditions

The manufacturer offers a two-year warranty on all parts of the hose pump. This means that all parts will be repaired or replaced free of charge, with the exception of consumables such as pump hoses, ball bearings, wear rings, seals and compression rings, or parts which have been used wrongly or have been misused, whether or not they have been intentionally damaged. If genuine Watson-Marlow Bredel B.V. (hereafter called Bredel) parts are not used, any warranty claim is void.

Damaged parts which are covered by the applicable warranty conditions can be returned to the manufacturer. The parts must be accompanied by a fully filled in and signed safety form as present in the back of this manual. The safety form must be applied to the outside of the shipping carton. Parts which have been contaminated or which have been corroded by chemicals or other substances which can pose a health risk must be cleaned before they are returned to the manufacturer. Furthermore, it should be indicated on the safety form which specific cleaning procedure has been followed, and that the equipment has been decontaminated. The safety form is required even if the parts have not been used.

Warranties purporting to be on behalf of Bredel made by any person, including representatives of Bredel, its subsidiaries, or its distributors, which do not accord with the terms of this warranty shall not be binding upon Bredel unless expressly approved in writing by a Director or Manager of Bredel.

4 Description

4.1 Identification of the product

The hose pump can be identified by identification plates or stickers on:

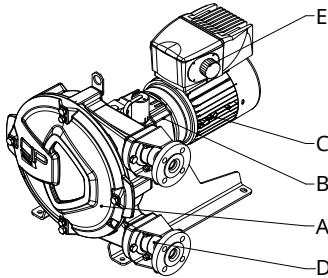

- | | | | |
|---|----------------|---|-------------------------------|
| A | Pumphead | D | Pump hose |
| B | Gearbox | E | Frequency controller (option) |
| C | Electric motor | | |

Identification of the pump

The identification plate on the pumphead contains the following data:

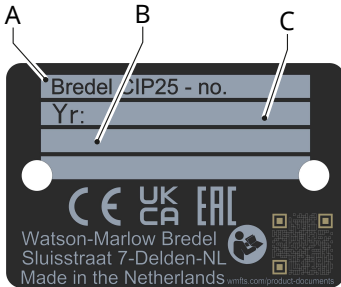

- | | | | |
|---|---------------------|---|---------------|
| A | Pump type | B | Serial number |
| C | Year of manufacture | | |

Identification of the gearbox

The identification plate on the gearbox contains the following data:

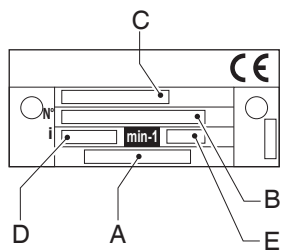

A Part number

D Reduction ratio

B Serial number

E Number of revolutions per minute

C Type number

Identification of the electric motor

The identification plate on the electric motor contains the following data:

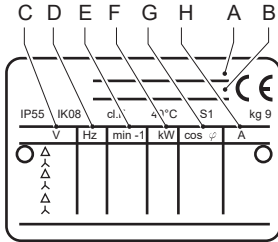

- A Part number
- B Serial number
- C Mains
- D Frequency

- E Speed
- F Power
- G Power factor
- H Current

Identification of the frequency controller

The identification of the Bredel Variable Frequency Drive (VFD) can be found inside the VFD. Remove the cover by loosening the two screws. The identification sticker contains the following data:

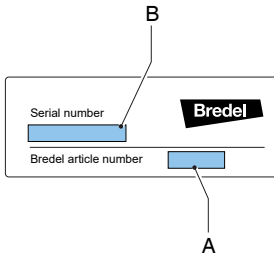

A Part number

B Manufacturer's serial number

Identification of the hose

The identification sticker on the pump hose contains the following data:

NR Metering hose

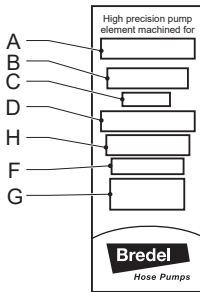

NR Transfer hose

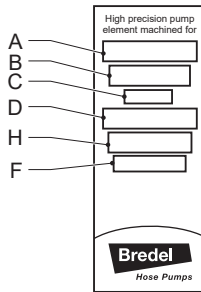

Other hoses

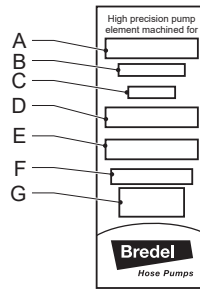

A Pump type

B Part number

C Internal diameter

D Type of material of inner liner

E Remarks, if applicable

F Maximum permissible working pressure

G Production code

H Hose type

4.2 Construction of the pump

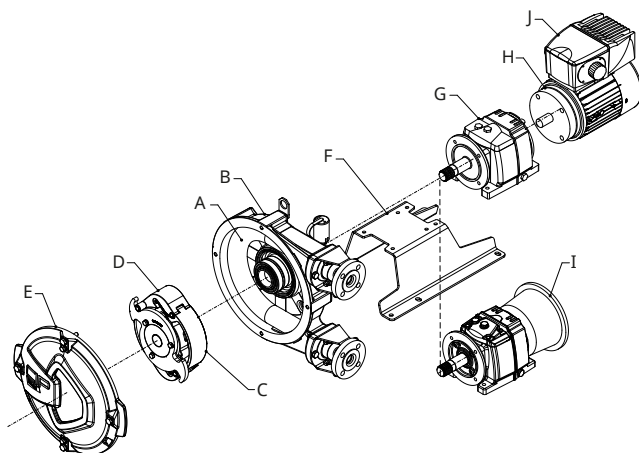

- | | | | |
|---|----------------|---|--------------------------------|
| A | Hose | F | Support |
| B | Pump housing | G | Gearbox |
| C | Rotor | H | Electric motor |
| D | Pressing shoes | I | Adapter without motor (option) |
| E | Cover | J | Frequency controller (option) |

4.3 Operation of the pump

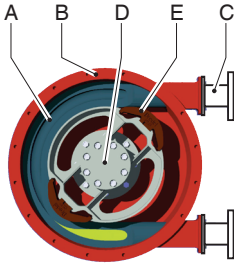

The heart of the pumphead consists of a specially constructed hose (A) which lies against the inside of the pump housing (B).

The ends of the hose are connected to the suction and discharge lines by means of a flange construction (C).

A rotor (D) with two facing pressing shoes (E) is in the centre of the pumphead. In this example, it rotates clockwise.

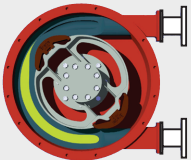
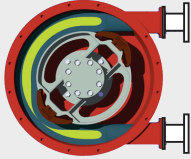
Phase	Description	Pump layout
1	The lower pressing shoe compresses the hose by the rotational movement of the rotor, forcing the fluid through the hose. As soon as the pressing shoe has passed, the hose recovers to its original shape sucking in new fluid.	
2	When the first pressing shoe leaves the pump hose, the second pressing shoe has already occluded the hose and fluid is prevented from flowing back. This method of liquid displacement is known as the "positive displacement principle".	

4.4 Pump installation positions

The pump can be delivered with the following possible pumphead installation positions:

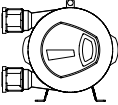
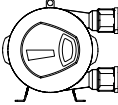
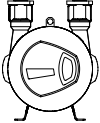
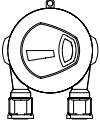
Position	Description	Pump layout
1	Pump ports at left hand side when facing the pump at the cover.	
2	Pump ports at right hand side when facing the pump at the cover.	
3	Pump ports facing upwards.	
4	Pump ports facing downwards.	

Cover position is the same for all pump positions, as indicated by inspection window position in the illustrations above. An accurate reading of the lubricant level through the inspection window is possible at every pump position.

The pump operational direction is determined by the configuration of the CIP rotor. By flipping the actuator disc the operation direction can be changed.

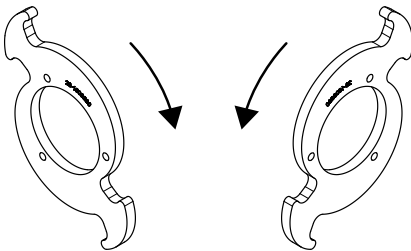

4.5 Hose

General

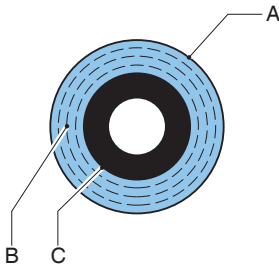

A Extruded or wrapped outer layer made of Natural Rubber C Extruded or wrapped inner liner
B Nylon reinforcement layers

The hose liner material should be chemically resistant to the process fluid being pumped. For each pump model various hose types are available. Choose the most appropriate for your application.

The material of the inner liner of the hose determines the hose type. Each hose type is marked by a unique colour code.

Liner type / material	Label colour
NR	Purple
NBR, NBR-F*, F-NBR*	Yellow
EPDM	Red
CSM	Blue

*See also

Dedicated manuals:

NBR hoses for food contact, part number 28-29211330

F-NBR hoses for food contact, part number 28-29211322

Note: Contact your Bredel representative for advice about the chemical and temperature resistance of the hoses.

The Bredel hoses are carefully manufactured and quality checked to achieve minimum tolerances in wall thickness.

It is very important to guarantee the correct compression of the hose, because:

- When the compression is too high, it creates an excessive load on the pump and hose, which may reduce the life of the hose and bearings.
- When the compression is too low, it cuts capacity and causes backflow. Backflow reduces the life of the hose.

Hose compression force adjustment

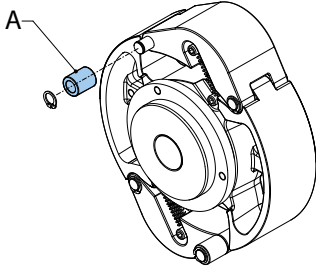

For optimal hose life, adjust the compression of the pump hose by placing the correct roller bushing (A).

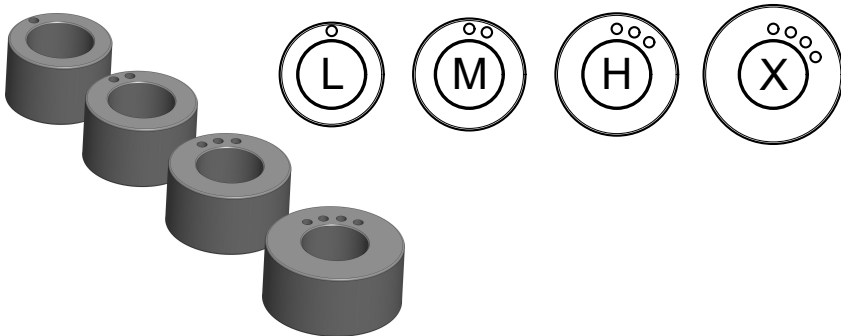

See also

Refer to "Hose compression specifications" on page 81

Refer to "Isolate the pump from the electrical supply." on page 60 for how to select and install the roller bush.

Lubrication and cooling

The pumphead is filled with Bredel Genuine Hose Lubricant. This lubricant lubricates the pressing shoes and dissipates the generated heat via the pump and the cover.

The user is responsible to ensure the chemical compatibility of the lubricant with the fluid to be pumped.

See also

Refer to "Lubricant table pump" on page 78 for the required quantity and NSF registration.

Refer to "Hose failure" on page 32 for the consequences of a hose failure.

Note: Consult your Bredel representative for advice on lubrication when operating the hose pump below 2 rpm.

4.6 Gearbox

The hose pump types described in this manual use co-axial gearbox units.

The gearboxes are fitted with a foot rest. The outgoing shaft has been fitted with a spline.

See also

Refer to "Gearbox" on page 82

Refer to "Specifications" on page 1

4.7 Electric motor

If the electric motor has been standard supplied by the manufacturer, it is a standardized squirrel-cage motor.

See also

Refer to "Specifications" on page 76

4.8 Frequency controller

Refer to the documentation supplied by the manufacturer.

See also

Refer to "Specifications" on page 76

Use of electric and electronic devices like electric motor and frequency controller require special configurations. For CIP configuration use is limited to non-ATEX only. In case of doubt, consult your Bredel representative..

4.9 Available options

The following options are available for the hose pump:

- High (lubricant) level float switch
- Low (lubricant) level float switch
- Revolution counter
- Stainless steel flanges, flange brackets, hose clamps, support and mounting parts
- Sanitary hose connection
- Pump support for non-standard gearbox types
- Adaption for universal gearbox
- Low, Medium, High, X-High bushings
- Frequency controller
- Special configuration for NSF
- Corrosion protection acc. ISO 12944/6-C4M, C4H or C5M

5 Installation

5.1 Unpacking and inspection

Unpacking

1. Unpack all parts carefully.
2. Retaining packaging until inspection is complete.

Inspection

1. Check all components present
2. Inspect components for damage in transit
3. Report missing components or damage to your local Bredel representative immediately

Packaging disposal

Dispose of packaging materials:

1. Safely
2. Responsibly
3. Recycle outer carton (corrugated cardboard)
4. Compliant to all relevant regulations

5.2 Installation conditions

Ambient conditions

Make sure that the hose pump is in an area where the ambient temperature during operation is not lower than -20 °C and not higher than +45 °C.

The minimum start-up temperature for the gearbox is -10 °C. A heater is required for temperatures below -10 °C.

Installation site

Installation specifications

Do not exceed ambient operating air temperature range (°C)	-20 °C to +45 °C
Maximum floor slope (mm per metre)	50

Note: Pump is suitable for indoor use. In case of outdoor use contact your Bredel representative for advice.

Installation site requirements:

- Flat
- Horizontal
- Rigid surface
- Rated to support full weight of complete assembly and pumped product
- Allow a free flow of air around the pump, gearbox and electric motor to dissipate heat
- Ensure sufficient access for all maintenance
- Free from excessive vibration

Pipework

- The bore size of the suction and discharge lines must be larger than the bore size of the pump hose. In case of doubt, consult your Bredel representative.
- Avoid sharp bends in the discharge line. Make sure that the radius of the bent discharge line is as large as possible. It is recommended to use Y-connections instead of T-connections.
- Keep the delivery and suction lines as short and direct as possible.
- Select the correct mounting material for flexible hoses and make sure that the installation is suited for the design pressure of the system.
- Do not exceed the maximum working pressure of the hose pump.
- Prevent the valves in the suction and discharge lines from being shut while the pump is running.

See also

Refer to "Performance" on page 76



CAUTION

Consider the maximum permissible working pressure on the discharge side. Exceeding the maximum working pressure may lead to serious damage to the pump.

- For the ease of hose changing and some pulsation suppression, it is recommended to use a segment of flexible hose between the pump flange and hard piping of the suction and/or discharge line. A segment of three quarters (3/4) of the pump hose length for the flexible pipe work is recommended. Bredel also recommends installing an isolation valve and pipedrain in the suction and discharge pipework to allow fluid isolation and drainage from the pump during maintenance. Following these recommendations will help to minimize the exposure of process fluid to maintenance personnel.

Make sure that the maximum forces on the flanges are not exceeded. The permissible loads are given in the following table.

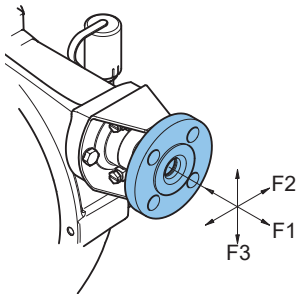

Maximum permissible loads [N] on the pump flange

Force	Bredel CIP25	Bredel CIP32
F1	600	600
F2	500	500
F3	200	200

Frequency controller



WARNING

A frequency controller that is fitted without manual control can start the pump automatically when power is applied.

If the hose pump is fitted with a frequency controller, consider the following points:

- Take precautions so the motor does not restart automatically after an unscheduled stop. In the event of a power or mechanical failure, the frequency controller stops the motor. When the cause of the failure is removed, the motor can restart automatically. The automatic restart can be dangerous in certain pump installations.
- All control cables outside the enclosure must be shielded and have a cross sectional area of at least 0.22mm². The shielding must be connected to earth at one end. In case of doubt, contact your Bredel representative for advice.

5.3 Lifting and moving the pump



Lifting should be performed according to standard Health and Safety guidelines and should be performed by qualified personnel only.

Use the lifting eye (A) on the pump housing to lift and move the hose pump.

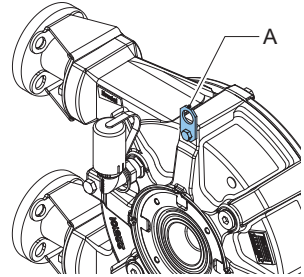

The complete hose pump (the pumphead, gearbox and electric motor) must be lifted using the lifting eye plus additional support using suitably rated straps or slings (A).

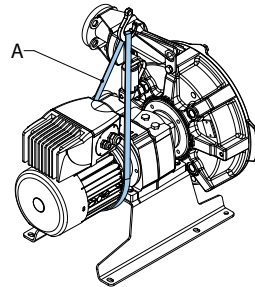

5.4 Placing the pump



Do not use holes (B) when the pump is placed on the leveling elements. This can cause the pump to tilt.



Do not use the holes in the pump supports to lift the hose pump.

The pump can be fixed to the floor using anchors. Alternatively the pump can be placed on the floor using levelling elements.

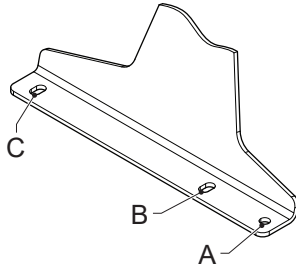

- In case of fixing to the floor use holes (A) or (B) and holes (C) at both sides of the pump.
- In case of levelling elements, use holes (A) and holes (C) at both sides of the pump.

Note: If the pump installation position is in position 4, then the use of levelling elements is not possible.

Using anchor bolts

Position the pump on a horizontal surface. Use suitable anchor bolts to attach the pump to the floor surface.

Follow the next steps to make sure the anchor bolts are used properly. Use the specifications below.

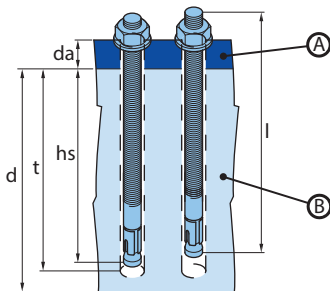

A. Pump support

B. Foundation

1. Drill the holes.
2. Clean the bore holes.
3. Use a hammer to drive the anchor bolt into the bore.
4. Tighten the bolt to the applicable torque setting (MD).

Item	Unit	Bredel CIP25	Bredel CIP32
Flange thickness (d _a)	mm	5	5
Flange hole diameter	mm	12 x 18	12 x 18
Anchor bolt part number	-	28-F550016	28-F550016
Bolt thread	-	M10	M10
Bolt length (l)	mm	85	85
Minimum foundation height (d)	mm	200	200
Drill diameter	mm	10	10
Minimum drill depth (t)	mm	70	70
Mounting depth (hs)	mm	60	60
Torque setting (MD)	Nm	30	30

Using levelling elements

Use four suitable levelling elements to place the pump on a horizontal surface. Adjust the elements such that the pump does not wobble and the weight of the pump is evenly spread over the elements at left hand and right hand sides.

Pump	Diameter holes (A) [mm]	Size holes (C) [mm]	Element thread diameter	Rated load capacity per element [kg]
Bredel CIP25	11	18x12	M10	110
Bredel CIP32	11	18x12	M10	150

6 Commissioning

6.1 Preparations



WARNING

A frequency controller that is fitted without manual control can start the pump automatically when power is applied.



WARNING

Disconnect and lock the power supply to the pump drive before any work is carried out. In case the motor is fitted with a frequency controller and has a single-phase power supply, wait two minutes to make sure that the capacitors have discharged.

1. Connect the electric motor and, if present, the frequency controller in conformance with the locally applicable rules and regulations. Have the electrical installation work carried out by qualified personnel.
2. Check that the lubricant level is above the minimum level line in the inspection window. If necessary refill with Bredel Genuine Hose Lubricant via the breather plug.
3. Check that the correct number of shims corresponds with your application.

See also

Refer to "Frequency controller" on page 23

Refer to "Changing lubricant" on page 39

Refer to "Specifications" on page 76

6.2 Commissioning

1. Connect the pipework.



CAUTION

Make sure that there are no obstructions such as closed valves.

2. Connect the pump to the electrical supply.
3. Switch on the electrical supply.
4. Check the rotation of the rotor.
5. Make sure that hose clamps are correctly fitted.
6. Check the capacity of the hose pump. If the capacity differs from your specification, follow the instructions in Troubleshooting or contact your Bredel representative for advice.
7. If a frequency controller is present, check the capacity range. In case of any deviations consult the supplier's documentation.
8. Check the hose pump in accordance with points 2 to 4 of the maintenance table.

See also

Refer to "Maintenance and periodic inspections" on page 35

Refer to "Tightening the hose clamps " on page 48 for how to tighten the hose clamps

Refer to "Troubleshooting" on page 68

7 Operation

7.1 Temperature

The pump will heat up during normal operation. This will result in a temperature higher than the ambient temperature.



WARNING

Avoid contact with the casing and cover under conditions of high pressure and running speed.

7.2 Power rating

Drive power and reduction ratio determine the pump operating condition.

See also

Refer to "Performance graphs" below to determine the required power.



WARNING

Overloading the motor can lead to serious motor damage. Do not exceed the maximum power rating of the motor.



WARNING

Overloading the gearbox leads to increased tooth wear and shortened bearing life. This can lead to serious gearbox damage. Do not exceed the maximum power rating of the gearbox.

7.3 Performance graphs

The pump and hose are designed to handle a discharge pressure up to 1600 kPa. The triangular area between the 500 kPa and the 1600 kPa lines describes the allowed performance area. The required duty points have to fall within this area. For discharge pressures lower than 500 kPa use the 500 kPa line.

In the direction of higher speeds and powers, pump operation is limited by the heat generated, the product temperature and the ambient temperature. Product temperature lines determine a distinction between areas of continuous operation and intermittent operation in the graphs. The graphs apply for a maximum ambient temperature of 45 °C.

If the duty for an application is specified in the area of intermittent operation, let the pump stand still to cool down for at least one hour after two hours of operation.

How to use the graphs

Required motor power in kW (HP)

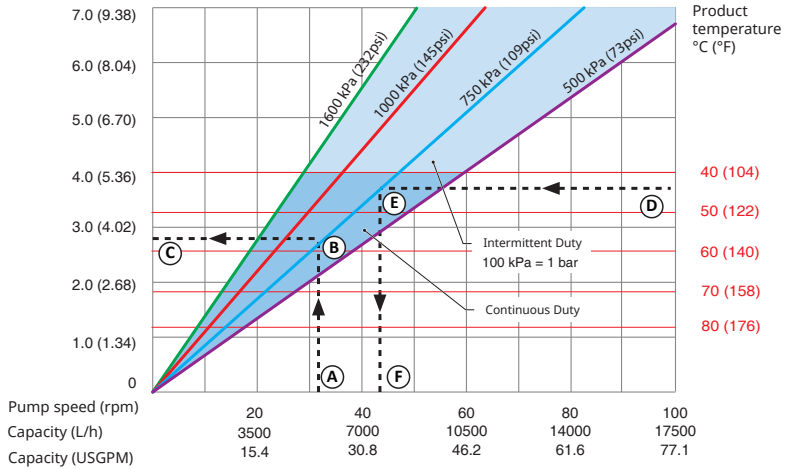

- | | |
|-------------------------------|-------------------------------|
| A Required flow or pump speed | D Product temperature |
| B Required discharge pressure | E Required discharge pressure |
| C Required motor power | F Maximum allowed pump speed |

Refer to the graph to understand how to use the graphs to determine the required motor power or the maximum allowed pump speed.

To determine the required motor power:

1. Start at the required flow or pump speed (A).
2. Meet the line of the required discharge pressure (B).
3. Read the required motor power (C).

To determine the maximum allowed pump speed:

1. Start at the product temperature (D)
2. Meet the line of the required discharge pressure (E).
3. Read the maximum allowed pump speed (F).

Note: Pump stroke volume is based on new hoses and flooded suction. Actual stroke volume may vary.

Performance graph Bredel CIP25

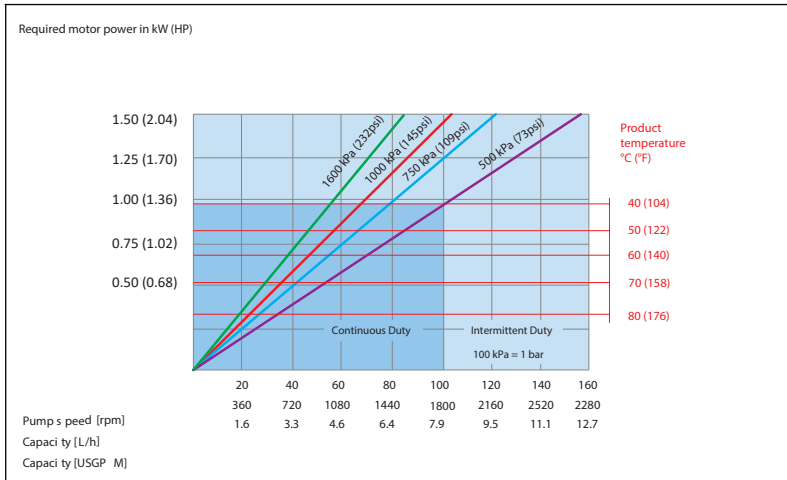

Performance graph Bredel CIP32

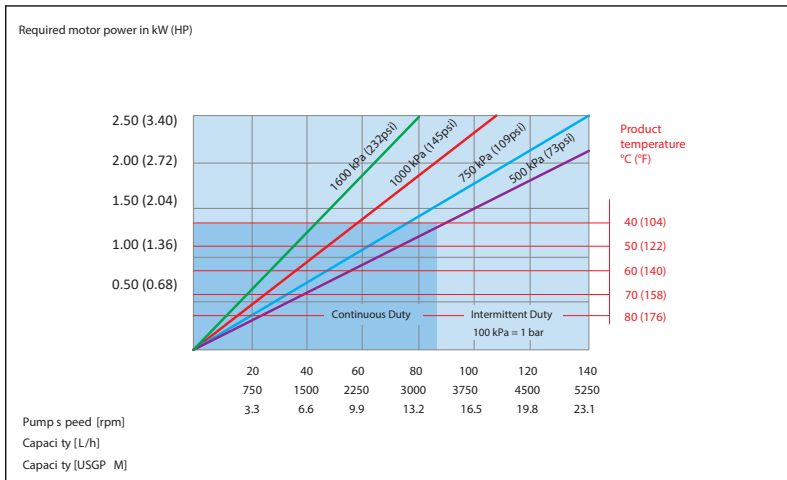

7.4 Dry running

Dry running is a running condition of the pump when no fluid is flowing through the hose. Bredel hose pumps allow dry running for limited periods.

Dry running imposes an additional thermal load on the hose.

To minimise the extra wear, limit dry running periods to less than one minute at a time.

7.5 Hose failure

Cause of a hose failure

The hose in a peristaltic pump has to withstand many load cycles of compression. The repetitive stress cycles will cause the hose to deteriorate and eventually fail.

Result of a hose failure

A hose failure will result in direct contact between the pumped fluid and the pump lubricant, the internal parts, and the dynamic seal.

Consequences of a hose failure

Process fluid can enter and contaminate the pump housing and lubricant. Thoroughly clean the interior before installing a new hose.

In general, this will not cause a hazardous situation because the Bredel Genuine Hose Lubricant is harmless (approved by the United States Food and Drug Administration). However, there is an exception in case of pumping a strong oxidiser or a strong acid. For example, sodium hypochlorite (NaClO), this can lead to exothermal reaction.

In case of doubt contact your Bredel representative.

See also

Refer to "Lubricant table pump" on page 78



WARNING

Avoid direct contact between a strong oxidiser or a strong acid and Bredel Genuine Hose Lubricant. This can cause unwanted chemical reactions. Use an alternative lubricant to avoid hazardous situations. In case of doubt, consult your Bredel representative..

Note: Regularly replace the hose to avoid hose failure and additional downtime. Hose life depends on the operating condition, process fluid and hose material. The end-user should be aware of this and establish the frequency of preventive hose replacement. In case of doubt, consult your Bredel representative.

Large spill of product

Stop pump immediately.

Operation after hose failure can lead to large spill of product.

It is strongly recommended to install a high level float switch.

See also

Refer to "Fitting options" on page 62

Install a check valve to prevent reverse flow when all following conditions occur simultaneously

- Hose fails
- Pump stops
- Process pressure exceeds ambient levels

7.6 Fluid leakage

The pump uses a lubricated rotor to compress the hose. This means the pumphead must be filled with sufficient lubricant during operation. This lubricant is contained in the pump housing by the front cover and by a dynamic seal on the back. The gearbox is filled with gearbox lubricant.

Seal damage can occur due to normal wear in time, but is seriously accelerated if the seal gets in contact with contaminated lubricant. Thorough cleaning of the pump housing after a hose failure and regular replacement of the lubricant is strongly advised.

Note: Regularly check the pumphead for any leakage around the cover, the hose connections, and the rear of the pumphead.

The pumphead and gearbox are directly coupled to each other. A special feature is included in the pumphead to allow early detection of seal damage of the pump or gearbox.

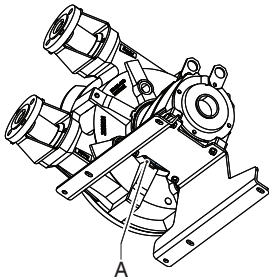

This feature is called the leakage zone (A). Drops of lubricant visible at the back of the pump indicate likely seal failure. To avoid consequential damage, the pump must be stopped and lubricant levels of the pumphead and gearbox must be checked. The damaged seal should be replaced.



WARNING

Risk of injury from falling! Process fluid mixed with pump lubricant that is leaking from the pump can make floors slippery.

8 Maintenance

8.1 General



WARNING

Disconnect and lock the power supply to the pump drive before any work is carried out. In case the motor is fitted with a frequency controller and has a single-phase power supply, wait two minutes to make sure that the capacitors have discharged.



WARNING

Do not remove the pump cover if the power cable is connected to the motor. Do not connect the power cable to the motor if the pump cover is removed.



CAUTION

Only use original Bredel parts when maintaining the hose pump. Bredel cannot guarantee correct operation and any consequential damage that occurs from the use of non-original Bredel components.



CAUTION

Check that all components are present. Inspect components for damage in transit. If anything is missing or damaged, contact your distributor immediately.

Note: Do not install damaged parts. If in doubt, contact your Bredel representative for advice.

8.2 Maintenance and periodic inspections

The following maintenance schedule shows the maintenance and periodic inspection that need to be carried out on the hose pump to guarantee optimal safety, operation and life of the pump.

Note: It is also necessary to carry out periodic inspection of the gearbox and the electric motor. Consult their separate manuals to guarantee an optimal safety, operation and life of the gearbox and the electric motor.

Item	Action	To be carried out	Remark
1.	Check the lubricant level.	Before start-up of the pump and at scheduled intervals during operation.	Check that the lubricant level is above the minimum level line in the inspection window. If necessary refill with Bredel Genuine Hose Lubricant via the breather plug. Refer to "Changing lubricant" on page 39
2.	Regularly check the pumphead for any leakage around the cover, the hose connections, and the rear of the pumphead.	Before start-up of the pump and at scheduled intervals during operation.	Refer to "Troubleshooting" on page 68
3.	Check the gearbox for any leakage.	Before start-up of the pump and at scheduled intervals during operation.	In case of doubt, consult your Bredel representative.
4.	Check the pump for deviating temperature or strange noises.	At scheduled intervals during operation.	Refer to "Troubleshooting" on page 68
5.	Check the pressing shoes for excessive wear or damage.	When replacing the hose.	Refer to "Changing the hose" on page 40
6.	Check the roller bushings and actuator disc for excessive wear.	When replacing the hose.	Refer to "Changing the hose" on page 40
7.	Internal cleaning of the hose.	Cleaning of the system or fluid change.	Refer to "Cleaning the hose" on page 38
8.	Replace the hose.	Preventive, this means after 75% of the hose life of the first hose.	Refer to "Changing the hose" on page 40

Item	Action	To be carried out	Remark
9.	Change the lubricant.	After every second hose change, after 5000 service hours, after a year or after hose rupture whichever comes first.	Refer to "Changing lubricant" on page 39
10.	Change the oil in the gearbox.	Refer to "Lubricant for gearbox" on page 81	
11.	Replace the pump seal.	If necessary.	Refer to "Exchanging replacement parts" on page 50
12.	Replace the actuation disc.	If the bushings need replacement and the disc surface is severely worn.	Refer to "Exchanging replacement parts" on page 50
13.	Replace the wear ring.	If necessary.	Refer to "Exchanging replacement parts" on page 50
14.	Replace the pressing shoes.	Wear on the running surface.	Refer to "Exchanging replacement parts" on page 50
15.	Replace the roller bushings / actuation disc.	Wear on the running surface.	Refer to "Exchanging replacement parts" on page 50
16.	Replace the bearings.	If necessary.	Refer to "Exchanging replacement parts" on page 50
17.	Maintenance and periodic inspection of the gearbox and motor.	Before start-up of the pump and at scheduled intervals during operation.	Refer to the manuals of the gearbox and the motor.

8.3 Cleaning the hose

With a lot of product fluids it is necessary to have the hose cleaned immediately after the pumping process to avoid hardening of the fluid inside. The inside of the hose can be easily cleaned by rinsing the pump with clean water. If a cleaning agent is added to the water, check if the hose liner material is resistant to it. Also check if the hose can resist the cleaning temperature. Special cleaning sponge balls are also available. Refer to the documentation of the cleaning products and the hose for more information.

A proper result of a cleaning process in this way is not guaranteed by Bredel, while it strongly depends on the type of pumped fluid and the cleaning fluid applied.

For food applications, cleaning procedures are more strict. Refer to the documentation supplied with the food hose.

In case of doubt, consult your Bredel representative.

8.4 Changing lubricant

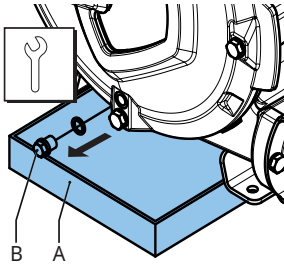

Note: The drain plug is in the cover of the pump.

1. Place a tray (A) under the drain plug. The tray must be large enough to contain the lubricant, possibly contaminated with product fluid, from the pumphead. Remove the drain plug (B). Collect the lubricant from the pump housing in the tray.
2. Position the drain plug and tighten it to the specified torque.

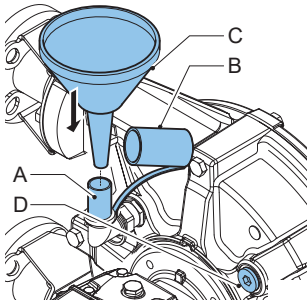

3. The pump housing can be filled with lubricant via the breather (A). For this purpose remove the breather cap (B) and position a funnel (C) in the breather. Pour the lubricant into the pump housing through the funnel.

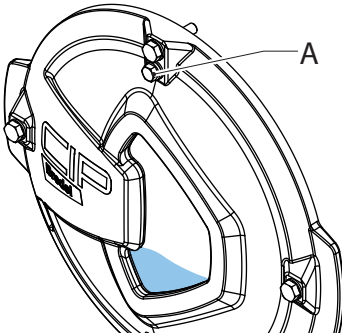

4. For ease of filling remove bolt (A) to allow air to escape. Replace bolt (A) after filling.
5. Pour until lubricant level aligns with lower left corner of the inspection window as shown in the diagram above.

See also

For the required quantity of lubricant, Refer to "Lubricant table pump" on page 78
Refer to "Torque figures" on page 80

8.5 Changing oil in the gearbox

1. Refer to documentation supplied with the motor and gearbox for the procedure on oil change.

8.6 Changing the hose

Removing the hose

1. Isolate the pump from the electrical supply.
2. Close any shut-off valves in the suction and discharge line to minimise the loss of process fluid.

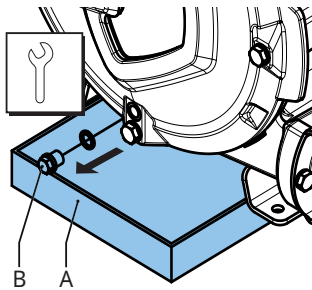

Note: The drain plug is in the cover of the pump.

3. Place a tray (A) under the drain plug. The tray must be large enough to contain the lubricant, possibly contaminated with product fluid, from the pumphead. Remove the drain plug (B). Collect the lubricant from the pump housing in the tray.
4. Check that the breather vent mounted on the rear is not obscured.
5. Position the drain plug and tighten it to the specified torque.

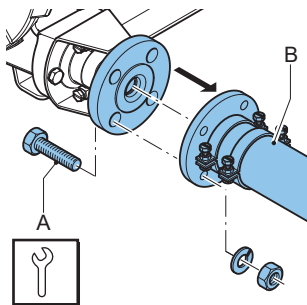

6. Loosen the retaining bolts (A) of both the suction and discharge line (B). Disconnect the suction and discharge lines.

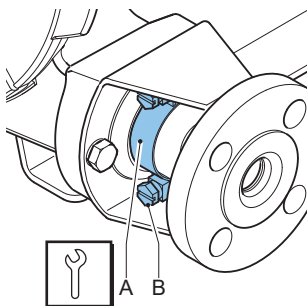

7. Loosen the hose clamp (A) of both the inlet and outlet ports by loosening the retaining bolt (B).

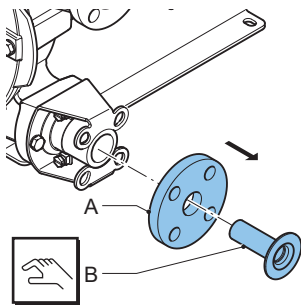

8. Pull the insert (B) from the hose and remove the flanges (A). Carry out this procedure both for the inlet and outlet ports.

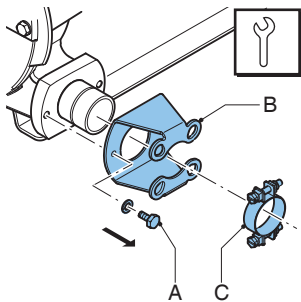

9. Loosen the retaining bolts (A) of the flange bracket (B) and remove the bolts. Slide the flange bracket and the hose clamp (C) off the hose. Carry out this procedure both for the inlet and outlet ports.

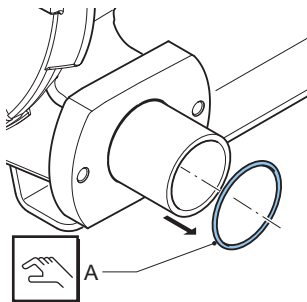

10. Slide off the sealing ring (A). Check that the sealing ring is not deformed or damaged and replace it if necessary. Carry out this procedure both for the inlet and outlet ports.
11. Connect the pump to the electrical supply.
12. Switch on the electrical supply.

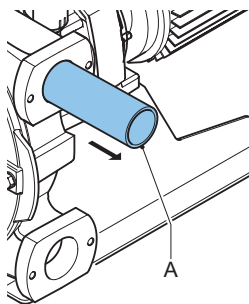

13. Power out the hose (A) from the pump chamber by jogging the drive motor in pump direction.

WARNING

During jogging the drive:



- Do not stand in front of the pump ports.
- Do not try to guide the hose by hand.
- Keep loose clothing and long hair away from pump ports and any moving parts.

See also

Refer to "Torque figures" on page 80

Cleaning the pumphead

1. Isolate the pump from the electrical supply.

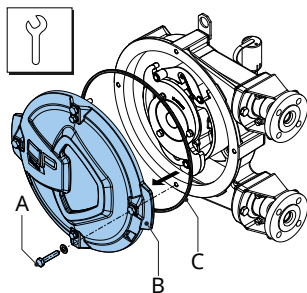

2. Remove the cover (B) by loosening the retaining bolts (A).
3. Check the sealing ring (C) is not damaged and replace it if necessary.

4. Rinse the pumphead with clean water and remove all residues. Make sure that no rinsing water remains in the pumphead.
5. Check the pressing shoes for wear or damage and replace them if necessary.

See also

Refer to "Maintenance and periodic inspections" on page 35



CAUTION

When the pressing shoes, roller bushings or actuation disc are worn the compression force of the hose decreases.

If the compression force is too low, this results in a loss of capacity by the backflow of the liquid to be pumped.

Backflow results in a reduction of the life of the hose.

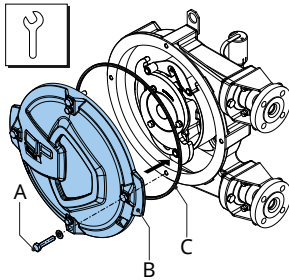

6. Place the seal ring (C) in the groove of the cover (B).
7. Place the cover (B). Make sure that the four bolts (A) are tightened in the correct order, diagonally opposite each other.
8. Connect the pump to the electrical supply.
9. Switch on the electrical supply.

See also

Refer to "Torque figures" on page 80

Fitting the hose — Standard flange bracket

1. Clean the (new) hose on the outside and fully lubricate the outside with Bredel Genuine Hose Lubricant.

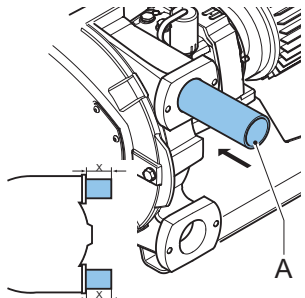

2. Make sure CIP rotor is in PUMP mode
3. Fit the hose (A) via the inlet port.
4. Run the motor so that the rotor pulls the hose into the pump housing. Stop the motor when the hose sticks out equally from both sides of the pump housing.

WARNING

During jogging the drive:



- Do not stand in front of the pump ports.
- Do not try to guide the hose by hand.
- Keep loose clothing and long hair away from pump ports and any moving parts.

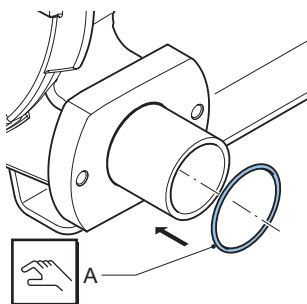

5. First fit the inlet port. Check the sealing ring (A) is not damaged and replace it if necessary. Fit the sealing ring.

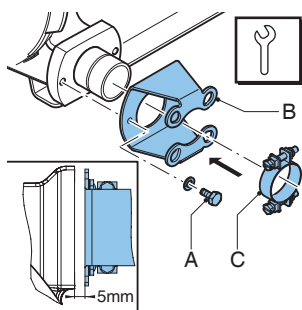

6. Check that the hose clamps (C) are not damaged and replace them if necessary.
7. Slide the flange bracket (B) and the hose clamp (C) over the hose together. Align the holes in the flange bracket with the ones at the front of the port. Position the retaining bolts (A) and tighten them until they are approx. 5 mm from the port, so that the gap between the flange bracket and the port remains.

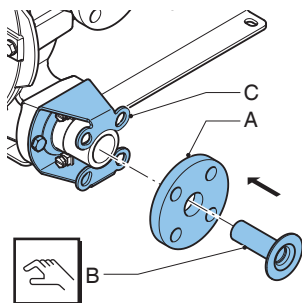

8. Slide insert (B) in flange (A) and press the insert in the hose. If necessary lubricate the insert with Bredel Genuine Hose Lubricant in order to simplify mounting. Make sure that the holes in flange (A) are aligned with the holes in flange bracket (C). Check that the insert is in the correct place. If the insert is not positioned correctly, the product to be pumped or the lubricant may leak.

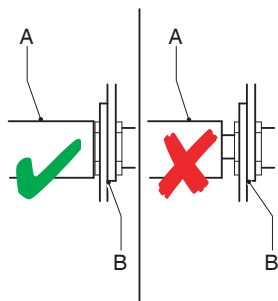

9. Turn the rotor in such a way that the hose (A) is pressed firmly against the flange surface .

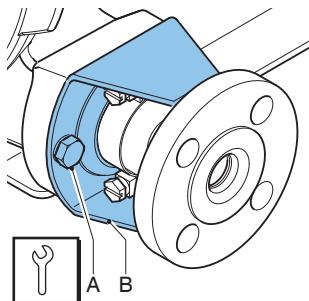

10. Fully tighten the retaining bolts (A) of the flange bracket (B). Make sure that the bolts are tightened to the specified torque.

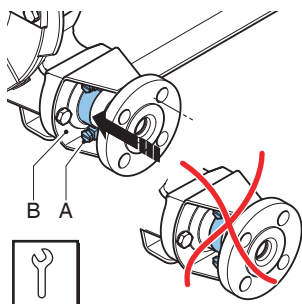

11. Position the hose clamp (A) against the O-ring chamber of the flange bracket (B) and fasten the retaining bolt.
12. Now fit the other port. For this port proceed in the same way as described above for the inlet port.
13. Fill the pump housing with Bredel Genuine Hose Lubricant.

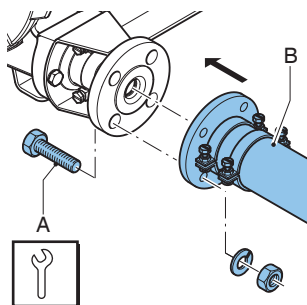

14. Connect the suction and discharge lines (B).
15. Position the retaining bolts (A) and tighten them to the specified torque.

See also

Refer to "Torque figures" on page 80

Refer to "Changing lubricant" on page 39

Refer to "Tightening the hose clamps " below

Tightening the hose clamps

How to tighten hose clamps in combination with steel inserts

As a first step, apply the initial setup torque value as advised in the table below. In some cases, an adjustment to the specified torque values is required. This can be due to excessive friction between the thread of the tightening bolt and the clamp. The actual clamping force needed can deviate from the clamping force derived from the specified torque values. To minimize this risk, it is advised to grease the clamping bolts.

If the specified torque values lead to a leaking hose connection, it is advised to carefully increase the bolt torque until a sealed situation is obtained. Here the absolute torque value is of less importance. The maximum allowable amount of clamping is indicated in the table below as a minimum allowable outer diameter of the clamp (OD). A suitable indication is the difference between hose outer diameter and clamp outer diameter ΔD .

Description	Bredel CIP25	Bredel CIP32
Initial setup torque, steel inserts [Nm]	20	20
Initial setup distance $\Delta D/2$ * [mm]	0	0
Minimum allowable clamp outer diameter (OD) [mm]	50	57
Approximate maximum distance $\Delta D/2$ * [mm]	2	2.5

* ΔD = difference of hose outer diameter and clamp outer diameter

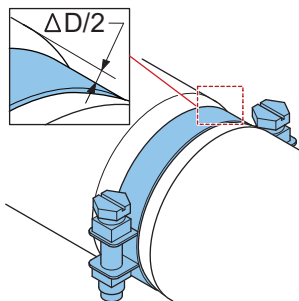

How to tighten hose clamps in combination with plastic inserts

Bredel pumps are supplied with one clamp per hose end as standard. The clamp is positioned close to the pump side to assure a sanitary connection between hose and insert. In case of plastic inserts, the amount of clamping must be limited to avoid deformation of the plastic insert which would lead to leakage instead.

As a first step apply the initial setup torque value as advised in the table below. Then carefully increase the torque and keeping the $\Delta D/2$ within the range specified. For operating pressures above 8 bar it is strongly recommended to place a second clamp close to the flange. This clamp can be tightened to seal up to 16 bar.

Description	Bredel CIP25	Bredel CIP32
Initial setup torque (plastic inserts)[Nm]	10	10
Initial setup distance $\Delta D/2$ * [mm]	0	0
Approximate maximum distance $\Delta D/2$ * at 0–8 bar (clamp near pump housing) [mm]	0.5	0.5
Approximate maximum distance $\Delta D/2$ * at 8–16 bar (clamp near flange) [mm]	1	1

* ΔD = difference of hose outer diameter and clamp outer diameter

Alternatively in case a sanitary connection is not required the single clamp can be repositioned close to the flange and tightened to seal up to 16 bar.

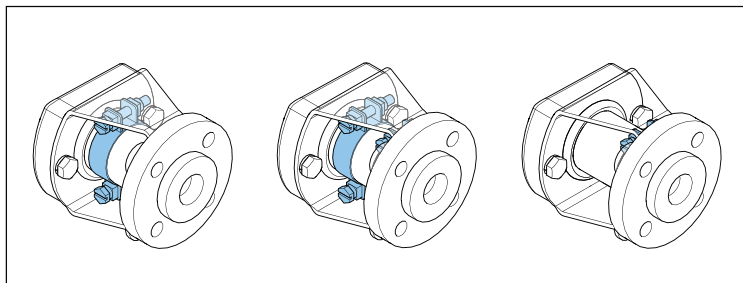

Left: Standard arrangement with one hose clamp near the pump housing. For low pressure demand.

Centre: Alternative arrangement with two hose clamps. For high pressure and sanitary demand.

Right: Alternative arrangement with one hose clamp near the flange. Only for high pressure demand.

8.7 Exchanging replacement parts

Replacing the rotor, casing seal, rotor wear ring and hub bearings

See also

Refer to "Torque figures" on page 1

Refer to "Changing the hose" on page 40

Refer to "Fitting the hose — Standard flange bracket" on page 45

Remove rotor

1. Remove the pump hose.
2. Isolate the pump from the electrical supply.

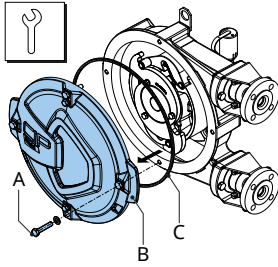

3. Remove the cover (B) by loosening the retaining bolts (A).
4. Check the gasket (C) for damage and replace it if necessary.

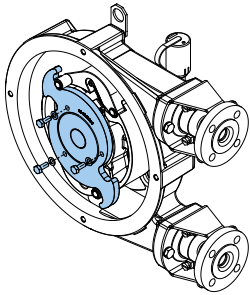

5. Remove the 3 bolts and gently pull out the actuation disc.

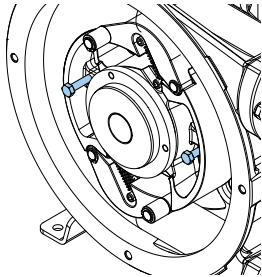

6. Insert the two push out bolts.

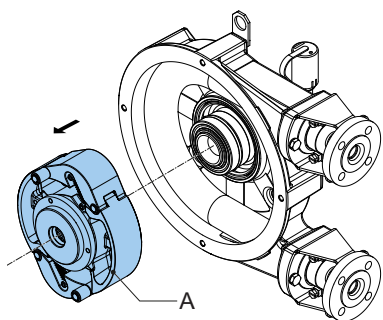

7. Tighten the bolts simultaneously one turn at a time. Gently push the rotor (A) from its seat until the spring ring releases the rotor. Now pull out the rotor by hand.

Remove/Refit bearings and seal

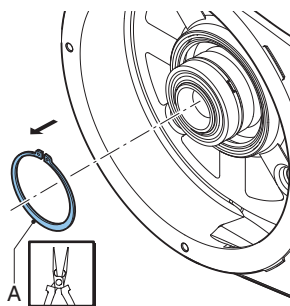

8. Dismount the retaining circlip (A) with the correct tool.

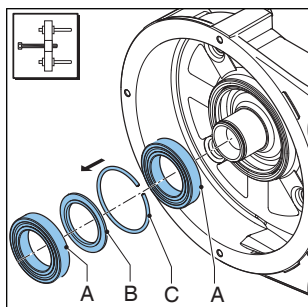

9. Remove the bearings (A), the spacer ring (B) and the retaining ring (C) with the correct tool.

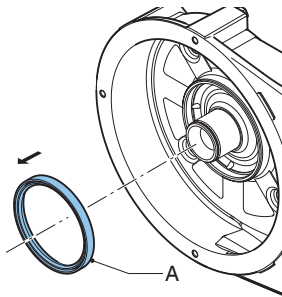

10. Remove the seal ring (A). Clean and degrease the bore.

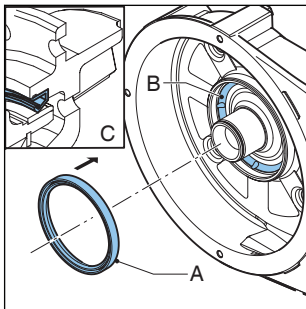

11. Gently press the new seal ring (A) into the cavity. The seal ring must be fitted in the correct orientation (C), with the open side towards the pump cover. If needed for ease of mounting, slightly oil the cavity area (B).
12. Slightly grease the seal lip of the dynamic seal (A).

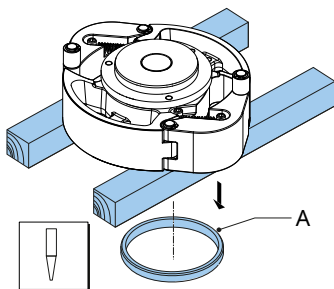

13. Support the rotor with wooden blocks at 90° to the spokes, with the wear ring (A) facing down. Position a suitable punch against the rear of the glued wear ring. Prevent damage to the wear ring seat or other parts.

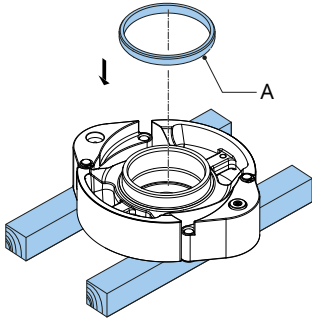

14. Turn the rotor over. Make sure that the seats of the new wear ring (A) and rotor are clean, dry and free of grease. Apply Loctite® type 641 or 603 both on the rotor and the wear ring. Position the new wear ring with the tapered edge facing up. Use a plastic hammer to fit the ring on the rotor until it touches the rotor completely.

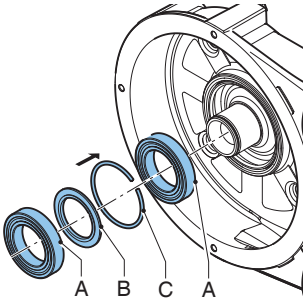

15. Check that the hub is clean and free of grease.
16. Fit the bearings and the rings. The bearings are placed on the hub with a slight interference fit. Use a pressing tool to press the bearings on the hub.

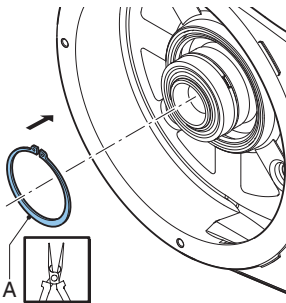

17. Check rotor retaining circlip (A) for any signs of damage and replace if necessary. Mount the retaining circlip (A). Use the correct tools for this purpose.

Refit rotor

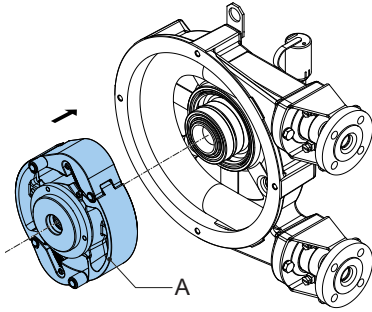

18. Fit the rotor (A). The rotor is placed on the bearings with a loose fit. Press the rotor on the hub until it clicks on the retaining ring.

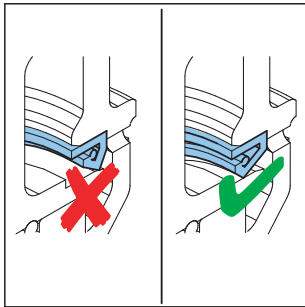

19. Check if the rotor can be turned by hand easily. If so, skip the next 2 steps. If turning requires excessive force, the lip of the seal is not properly positioned on the rotor seal area. Continue to the next step.
20. Remove the rotor.
21. If there is no damage to the seal then the rotor can be refitted. If the seal is damaged, then replace the seal and refit the rotor

See also

Refer to "Remove rotor" on page 50

Refer to "Remove/Refit bearings and seal" on page 52

Refer to "Torque figures" on page 80

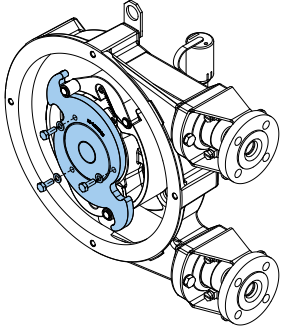

22. Install the actuation disc and mounting bolts. Make sure orientation matches pump direction.

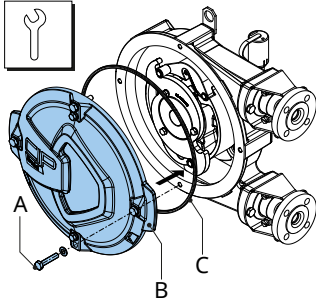

23. Check the sealing ring (C) is not damaged and replace it if necessary.
24. Place the cover (B). Make sure that the four bolts (A) are tightened in the correct order, diagonally opposite each other.
25. Connect the pump to the electrical supply.
26. Switch on the electrical supply.
27. Fit the (new) pump hose.

Replacing the seal and bearing of the base rotor

1. Remove the pump hose.

See also

Refer to "Changing the hose" on page 40

2. Isolate the pump from the electrical supply.
3. Remove the cover.
4. Remove the actuation disc and rotor assembly.

See also

Refer to "Replacing the rotor, casing seal, rotor wear ring and hub bearings" on page 50

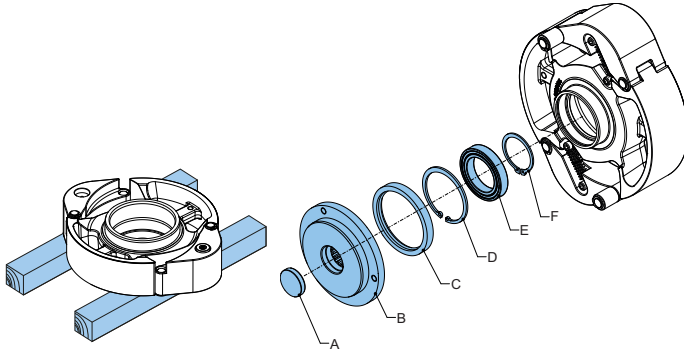

5. Put the rotor on blocks and remove the circlip (F) from the inside of the drive shaft (B). Gently push out drive shaft (B).
6. Gently remove seal (C) from drive shaft (B). Clean the seal seat, add some grease and gently mount the new seal. Use a cylinder with OD=85mm and ID=81 mm to push the seal into the seat.
7. Remove circlip (D) and gently pull out bearing (E) from the rotor.
8. Grease the bearing seat and install new bearing (E) in the rotor and mount circlip (D), replace if necessary.
9. Grease the lip of the seal (C) and gently place the drive shaft into the rotor. Rotate the drive shaft to make sure parts are assembled correctly.
10. Mount circlip (F), replace if necessary.
11. Mount the rotor assembly.

See also

Refer to "Replacing the rotor, casing seal, rotor wear ring and hub bearings" on page 50

Replacing shoes and roller bushings

1. Remove the pump hose.

See also

Refer to "Changing the hose" on page 40

2. Isolate the pump from the electrical supply.
3. Remove the cover.
4. Remove the actuation disc and rotor assembly.

See also

Refer to "Replacing the rotor, casing seal, rotor wear ring and hub bearings" on page 50

5. Lay the rotor on a flat surface with the roller bush facing upward.

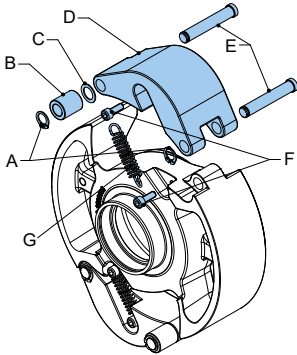

6. Remove bolts (F) and spring (G).
7. Remove circlips (A), roller bush (B) and shim ring (C). Check for wear and damage.
8. Pull out both pins (E).
9. Exchange shoe (D) and replace the pins (E). Do not swap the pins.
10. Place shim ring (C) and new roller bush (B) onto pin (E) and mount the circlips (A). Use new shim ring and circlips if needed.
11. Replace bolts (F) and spring (G).
12. Repeat steps for other shoe.
13. Mount the rotor assembly.

See also

Refer to "Replacing the rotor, casing seal, rotor wear ring and hub bearings" on page 50

Bredel 25-32 retrofit of CIP rotor

The Bredel 25-32 pump can be turned into a CIP25-32 by replacing existing rotor and front cover.

1. Referring to Bredel 25-32 manual, remove Bredel 25-32 rotor.
2. Install new bearings and seal and CIP rotor (recommended).

See also

Refer to "Replacing the rotor, casing seal, rotor wear ring and hub bearings" on page 50

3. Remove drain plug and seal from cover.
4. Mount drain plug and seal to new CIP cover.
5. Check cover seal for damage. Replace if needed. Install cover seal together with new cover.

After the upgrade the following parts are redundant:

- Bredel 25-32 rotor
- Bredel 25-32 front cover

8.8 Adjust the compression force (shimming)

See also

Refer to "Torque figures" on page 80

Refer to "Changing the hose" on page 40

Refer to "Fitting the hose – Standard flange bracket" on page 45

Refer to "Changing lubricant" on page 39

Refer to "Hose compression specifications" on page 81

1. Isolate the pump from the electrical supply.
2. Make sure the pump is in CIP position.

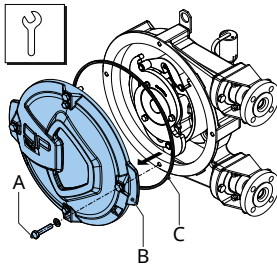

3. Remove the cover (B) by loosening the retaining bolts (A).
4. Check the gasket (C) for damage and replace it if necessary.



CAUTION

Installation of the wrong roller bush can lead to increased wear and short hose life. Too large roller bush means unnecessary over compression and energy consumption. Too small roller bush can lead to loss of flow rate.

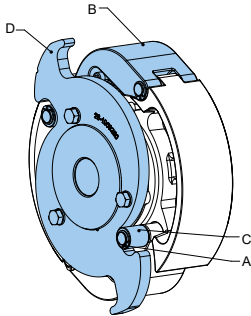

5. Remove the circlip (A). Lift the shoe (B) from the actuation disc (D) and remove the roller bushings (C).
6. Make sure you have the correct roller bushing size and install them in reversed order.

See also

Refer to "Hose compression force adjustment" on page 18

7. Inspect the surface condition of the actuation disc (D). Replace in case of signs of severe wear.

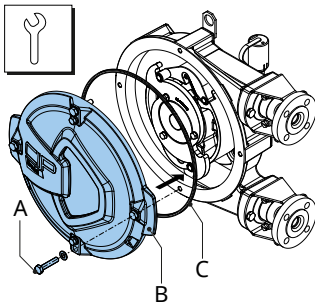

8. Place the seal ring (C) in the groove of the cover (B).
9. Mount cover (B) by tightening bolts (A).
10. Place the cover (B). Make sure that the four bolts (A) are tightened in the correct order, diagonally opposite each other.
11. Connect the pump to the electrical supply.
12. Switch on the electrical supply.

8.9 Fitting options

Fitting a high level float switch

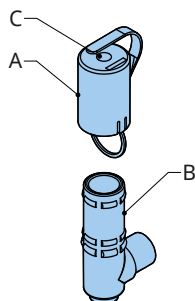

1. Remove cap (A)
2. Remove plug (C) from cap (A)
3. From bottom of cap (A) pass the float switch cable up through the hole in top of cap (A)
4. Slide the high level float switch into breather (B).
5. Put cap (A) onto breather (B).

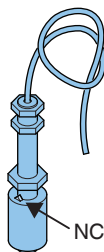

- Connect the high-level float switch to the auxiliary power circuit via the 2 metre long PVC cable (2 x 0.34 mm²). Bear in mind that the electrical contact of the float switch is normally closed (NC). The knob is upwards for normally closed operation. When the lubricant level is (too) high the contact will open.

Specifications

Voltage	Max. 230 V AC/DC
Current	Max. 2 A
Power	Max. 40 VA

Note: Where the float switch is constructed to stop the equipment, operating has to be arranged so that the stop function locks out, preventing the equipment from being restarted without resetting. Check if the float switch is mounted with the NC sign at the top.

Fitting a high and low-level float switch

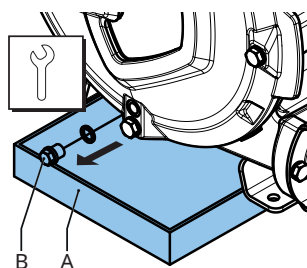

- If the pump is filled with lubricant this must be removed first.

Note: The drain plug is in the cover of the pump.

- Place a tray (A) under the drain plug. The tray must be large enough to contain the lubricant, possibly contaminated with product fluid, from the pumphead. Remove the drain plug (B). Collect the lubricant from the pump housing in the tray.
- Position the drain plug and tighten it to the specified torque.

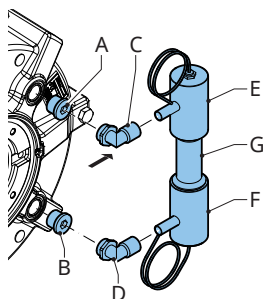

4. Dismount the plugs (A) and (B) on the rear of the pumphead.
5. Position the quick couplings (C) and (D) in both openings.
6. Clamp both connection tubes (E) and (F) on the riser pipe (G) and the quick links (C, D).
7. Connect the high and low level float switch to the electrical supply. Bear in mind that the electrical contact of the float switch is normally closed (NC). This means that:
 - the contact of the high level float switch opens at a (too) high lubricant level
 - the contact of the low level float switch opens at a (too) low lubricant level
8. Make sure the lubricant returns to the prescribed level.

See also

Refer to "Changing lubricant" on page 39

Specifications

Voltage	Max. 230 V AC/DC
Current	Max. 2 A
Power	Max. 40 VA

Note: Where the float switch is constructed to stop the equipment, operating has to be arranged so that the stop function locks out, preventing the equipment from being restarted without resetting. Check if the float switch is mounted with the NC sign at the top.

Replacing a revolution counter

For revolution counting the pump must be prepared with a sensor and a pressing shoe with a magnet. The sensor generates one pulse per revolution. Consult your Bredel representative for more information. This section describes the replacement of the sensor only.

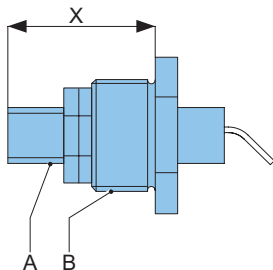

1. Fit the inductive sensor (A) in stop (B) and adjust it to dimension "X" as indicated in the table below. Tighten the adjusting nuts with a torque of 25 Nm.

Dimension "X" ± 0.1 mm

Bredel CIP25

26 mm

Bredel CIP32

28.5 mm

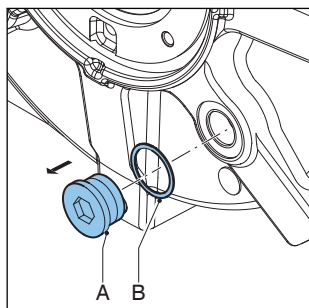

2. Dismount stop (A) at the rear of the pump housing. Check that the sealing ring (B) is not damaged and replace it if necessary.

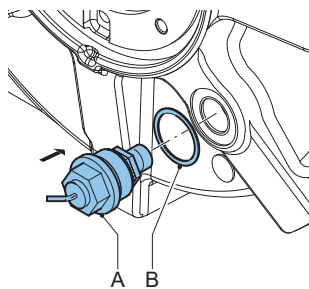

- Fit the stop with the inductive sensor (A) together with sealing ring (B) on the pump housing.

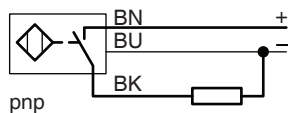

- Connect the sensor via the 2- metre long PVC cable (3 x 0.34 mm²).

Specifications

Voltage	10-30 VDC
Current	max. 150 mA

- Make sure that the lubricant returns to the prescribed level.

See also

Refer to "Changing lubricant" on page 39

9 Storage

9.1 Hose pump

- Store the hose pump and pump parts in a dry area. Make sure that the hose pump and pump parts are not exposed to temperatures lower than $-40\text{ }^{\circ}\text{C}$ or higher than $+70\text{ }^{\circ}\text{C}$.
- Cover the openings of the inlet and outlet ports.
- Prevent corrosion of untreated parts. For this purpose use the correct protection or packaging.
- Before a long period of standstill or storage, put pump in CIP mode to prevent permanent hose deformation

To prevent deformation of the hose, always store the pump when the rotor is in CIP mode.



WARNING

Do not jog rotors with the electrical drive when the front cover is removed.

9.2 Hose

- The maximum shelf life for the hose is 2 years. Store the hose in a dark and dry place with temperatures between $0\text{ }^{\circ}\text{C}$ and $40\text{ }^{\circ}\text{C}$. After two years the hose material will age, which will reduce the life of the hose.

9.3 Lubricant

- Replace the pump lubricant in case of failure of the pump hose and in any case after one year.
- Use the lubricant before the best-before date marked on the container.
- The lubricant must be stored in closed bottles or cans to avoid absorption of moisture.

10 Troubleshooting



WARNING

Disconnect and lock out the power supply to the pump drive before any work is carried out. In case the motor is fitted with a frequency controller and has a single-phase power supply, wait two minutes to make sure that the capacitors have discharged.

If the hose pump does not function (correctly), consult the following check list to see if you can remedy the error yourself. If you cannot, contact your Bredel representative for advice.

Problem	Possible cause	Correction
Failure to operate.	No voltage.	Check if the power supply switch is on.
		Check if the electrical supply is available at the pump.
	Stalled rotor.	Check if the pump is stalled by incorrect fitting of the hose.
		Check any possible blockage inside the hose.
		Check the frequency controller settings, if applicable.
	Lubricant level monitoring system has been activated.	Check if the lubricant level monitoring system has stalled the pump.
Check the functioning of the lubricant level monitoring system, and check the lubricant level.		

Problem	Possible cause	Correction
High pump temperature.	Non-standard hose lubricant used.	In case of doubt, consult your Bredel representative.
	Low lubricant level.	Add Bredel Genuine Hose Lubricant. For the required amount of lubricant Refer to "Lubricant table pump" on page 78
	Product temperature too high.	Check the performance graph. Refer to "How to use the graphs" on page 30
	Internal friction on the hose caused by blocked or poor suction characteristics.	Check pipework/ valves for blockages. Ensure that the suction pipework is as short as possible and that the diameter is large enough.
	Over-shimming of the pump rotor shoes.	Consult the diagram. . Remove excess shims.
	Too much hose compression.	Check installation of correct roller bush Refer to "Specifications" on page 76
	High pump speed.	Reduce pump speed to a minimum. Contact your Bredel representative for advice on optimum pump speeds.

Problem	Possible cause	Correction
Low capacity / pressure.	Shut-off valve in the suction line (partly) closed.	Fully open the shutoff valve.

Problem	Possible cause	Correction
	Insufficient hose compression.	<p>Check condition of actuator disc and roller bushing surface for signs of excessive wear. Replace if needed.</p> <p>Check installation of correct roller bush Refer to "Specifications" on page 76</p>
	Hose rupture or badly worn hose.	Replace the hose. Refer to "Changing the hose" on page 40
	(Partial) blockage of the suction line or too little product on the suction side.	Ensure that the suction line is clear of blockages and that sufficient product is available.
	Connections and hose clamps not correctly mounted, which makes the pump suck air.	Check the connections and the hose clamps. Tighten if necessary.
	The filling degree of the pump hose is too low, because the speed is too high in relation to the viscosity of the product to be pumped and the inlet pressure. The suction line can be too long or too narrow or a combination of these factors.	In case of doubt, consult your Bredel representative.
	Severely worn pressing shoes	Check surface condition of the pressing shoes. Replace if necessary.
	Wrong orientation of actuation disc.	Check if arrow on actuation disc corresponds to pump operational direction.
	PUMP mode not fully engaged.	<p>Large resistance to rotate actuation disc relative to rotor due to worn seal and damaged bearing. Replace if necessary.</p> <p>Large resistance to rotate actuation disc relative to rotor due to worn actuation disc and roller bushings. Replace if necessary.</p>

Problem	Possible cause	Correction
Vibration of the pump and pipework.	Suction and discharge lines are not secured correctly.	Check and secure pipework.
	High pump speed with long suction and discharge lines or high relative density or a combination of these factors.	Reduce pump speed. Reduce the line lengths on both suction and discharge where possible. In case of doubt, consult your Bredel representative.
	Too narrow diameter of suction and/or discharge line.	Increase the diameter of the suction/ discharge lines.
Short hose life.	Chemical attack of the hose.	Check the compatibility of the hose material with the product to be pumped. In case of doubt, consult your Bredel representative.
	High pump speed.	Reduce pump speed.
	High discharge pressures.	Maximum working pressure depends on the hose type. Check that the discharge line is not blocked, the shut-off valves are fully opened and the pressure relief valve functions properly (if present in the discharge line).
	High product temperature.	In case of doubt, consult your Bredel representative.
	High pulsations.	Restructure the discharge and inlet conditions.
	Too much hose compression.	Check if the correct roller bush is installed, Refer to "Hose compression force adjustment" on page 18

Problem	Possible cause	Correction
Hose pulled into the pump.	Insufficient or no hose lubricant in the pumphead.	Add extra lubricant. Refer to "Changing lubricant" on page 39.
	Incorrect lubricant: no Bredel Genuine Hose Lubricant in the pumphead.	In case of doubt, consult your Bredel representative.
	hose clamp insufficiently tightened.	Adjust specified torque. Refer to "Tightening the hose clamps " on page 48.
	Too high inlet pressure - larger than 300 kPa.	Reduce the inlet pressure.
	Hose blocked by an incompressible object in the hose. The hose cannot be compressed and will be pulled into the pump housing.	Remove hose, check for blockages and replace if necessary.
Lubricant leakage at bracket.	Poor suction conditions, highly viscous flow, or flow with high solid content.	Attach a second hose clamp per hose end. This hose clamp must be tightened to the maximum value. Refer to "Tightening the hose clamps " on page 48.
	Bolts of the bracket are loose.	Tighten to the specified torque settings. Refer to "Torque figures" on page 80
Leakage from the rear of the pump housing "Buffer zone".	Bolts of the hose clamps are loose.	Tighten the hose clamps. Refer to "Tightening the hose clamps " on page 48
	Damaged wear or seal ring.	Replace wear or seal ring.
Motor functions, but rotor does not.	Broken fracture surface on rotor.	Replace the rotor.

Problem	Possible cause	Correction
Leakage of product medium between the hose and the insert.	Steel insert: the hose clamp is not tightened strong enough.	Refer to "Tightening the hose clamps " on page 48 for the procedure and correct torque value.
	Plastic insert: the hose clamp is tightened too much and as a result the insert is deformed.	Loosen the hose clamp and inspect the insert. Replace the insert if necessary. Refer to "Tightening the hose clamps " on page 48
Lubricant leakage between the pump housing and the hose.	Steel insert: the hose clamp is tightened too much.	Refer to "Tightening the hose clamps " on page 48
	The O-ring in the bracket is damaged, or not correctly positioned in the bracket.	Inspect the O-ring and replace it if necessary. Lubricate the O-ring before installation with Bredel Genuine Hose Lubricant. Refer to "Fitting the hose — Standard flange bracket" on page 45
	Plastic insert: the hose clamp is tightened too much and as a result the insert is deformed.	Inspect the insert and replace it if necessary. Tighten the hose clamp. Refer to "Tightening the hose clamps " on page 48.

11 Specifications

11.1 Pumphead

Performance

Description	Bredel CIP25	Bredel CIP32
Max. capacity, continuous [m ³ /h]	1.80	3.25
Max. capacity, intermittent [m ³ /h]*	2.88	5.25
Capacity per revolution [l/rev]	0.300	0.625
Max. permissible inlet pressure [kPa]	350	300
Max. permissible working pressure [kPa]	1600	
Permissible ambient temperature [°C]	-20 to +45	
Permissible fluid temperature [°C]	-10 to +80	
Sound level at 1 m [dB(A)]	70	

* Intermittent duty: Let the pump stand still to cool down for at least one hour after two hours of operation.

Materials

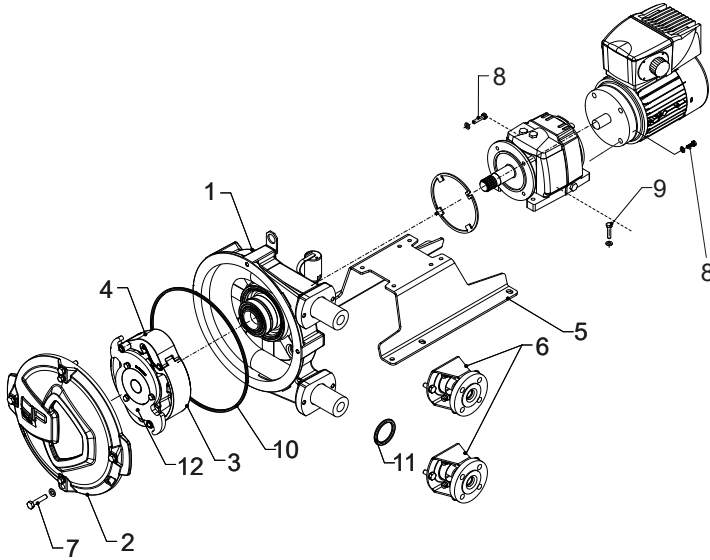

Pos	Description	Material
1	Pump housing	Cast iron
2	Cover	Cast iron
3	Pump base rotor	Cast iron
4	Pressing shoe	Steel
5	Pump support	Mild steel, galvanised
6	Flange bracket	Mild steel, galvanised
7	Mounting material of pump cover	Mild steel, galvanised
8	Mounting material of drive system	Mild steel, galvanised
9	Mounting material of pump support	Mild steel, galvanised
10	Cover seal	EPDM
11	Bracket seals	NBR
12	Actuation disc	Steel

After surface preparation, two layers of two-component water born paint is used for surface protection. Standard colour is RAL9010. Contact your Bredel representative for advice on surface treatment.

All galvanised parts have an electrolytic zinc layer of 15 - 20 µm.

Lubricant table pump

Item	Bredel CIP25	Bredel CIP32
Lubricant	Bredel Genuine Hose Lubricant*	Bredel Genuine Hose Lubricant*
Required quantity [litres]	2	3.5

*Bredel Genuine Hose Lubricant is registered at NSF: NSF Registration No 123204; Category Code H1. Also refer to: www.nsf.org/certified-products-systems, and search for 'Bredel'.

Components		
Glycerol	(C ₃ H ₈ O ₃)	50-100% w/w
Glycol	(C ₃ H ₈ O ₂)	2.5-10% w/w
Water	(H ₂ O)	

Note: Contact your Bredel representative for advice if you require additional information with respect to the safety data sheet.



WARNING

It is the users responsibility to ensure the chemical compatibility of the fluid to be pumped with the lubricant in the pumpehead. Obey the local Health and Safety regulations.

An alternative lubricant is available based on silicone. Also compatibility with this lubricant must be checked if applied. Refer to the chemical compatibility chart at www.wmfts.com/en/support/chemical-compatibility-guide/ or contact your Bredel representative for advice.

Weights

Description	Weight [kg]	
	Bredel CIP25	Bredel CIP32
Pumphead	41	62.4
Flange connection (2x), without inserts	3.7	5.5
Stainless steel insert (2x)	0.3	0.4
Hose	2	3
Lubricant	2.5	4.4
Sub total pumphead	49.7	75.7
Pump support	5.7	7.1
Mounting material gearbox to pumphead	0.3	0.3
Gearbox	15.5	21
Electric motor	17.3	25.7
Variable Frequency Drive	3	3
Total weight of unit	91.5	132.8
Pump cover (with inspection window)	13.5	15.8
Rotor	7.7	12.5
Pressing shoe	1.7	2.7

Torque figures

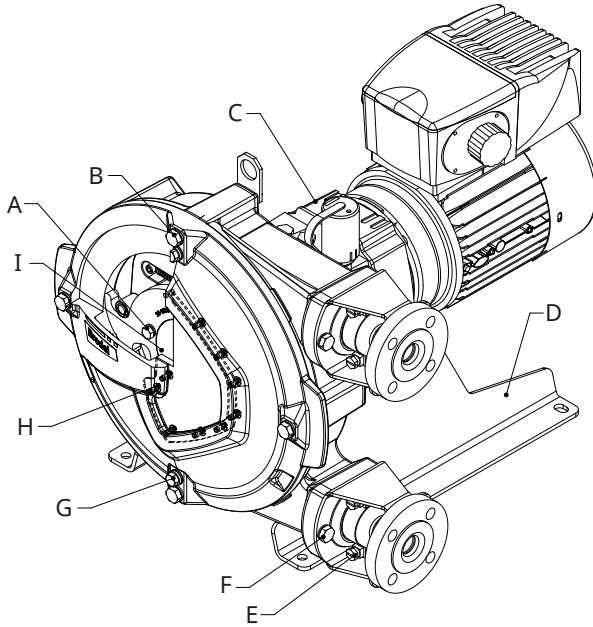

Pos	Description	Torque [Nm]	
		Bredel CIP25	Bredel CIP32
A	Actuation disc	25	25
B	Cover	50	50
C	Gearbox	25	50
D	Support	25	85
E	Hose clamp*	20	20
F	Flange bracket	50	50
G	Drain plug	10	10
H	Inspection window	2.5	2.5

See also

*Refer to "Changing the hose" on page 40

Hose compression specifications

Hose compression is set by using the correct roller bushing.

See also

Refer to "Hose compression force adjustment" on page 18

Discharge pressure

Bredel CIP 25 / CIP 32

$p \leq 4$ bar	O	L
$p > 4$; $p \leq 7$ bar	OO	M
$p > 7$; $p \leq 10$ bar	OOO	H
$p > 10$; $p \leq 16$ bar*	OOOO	X

*for the NR Transfer hose the maximum pressure is 12 bar.

Lubricant for gearbox

In the majority of the cases a mineral oil ISO VG 150 or ISO VG 220 is recommended. In case of very low ambient temperatures a mineral ISO VG 100 is advised. In case of high ambient temperatures or a relatively wide range of ambient temperatures a synthetic oil is recommended. Also in case of very high loads, resulting in high operating temperatures a synthetic oil is to be preferred.

Use of oil with EP (Extreme Pressure) additives is strongly recommended. Do not mix oils of different types, i.e. mineral, polyglycol and other synthetic lubricant. Refer to the documentation supplied with the gearbox for how to care about lubrication. For the food industry as well as for agricultural areas and nature reserves, special grade lubricants are available.

The table below is an indication for proper viscosity values.

If you have any questions, contact your Bredel representative for advice.

Recommended lubricant parameters for the Bredel gearboxes

	Mineral Oil			Synthetic oil
Ambient temperature	-20 to +5 °C	+5 to +30 °C	+30 to +50 °C	-30 to +65 °C
Viscosity acc. to ISO 3448	VG 100	VG 150-220	VG 320	VG 150-220
Oil change interval	5,000 hours			20,000 hours

Gearbox

Co-axial gearbox with helical gears. Standard as a 2 and 3 stage version.

Mounting position	IM 2001 (IM B35) foot flange gearbox with splined shaft in horizontal position.
Motor adapter	Electric motor has been integrated in the gearbox housing, by which the smallest possible dimension is achieved.
Optional motor adapter	Adapters in conformance with IEC-B5 or NEMA TC.

Electric motor

The standard electric motor is an enclosed three-phase asynchronous motor, suitable for use in combination with a frequency inverter. As a standard, PTC temperature sensors are built-in.

Note: In case of doubt about the local applicable regulations for the drive connection, contact your Bredel representative.

Protection class	IP55/IK08
Insulation class	F
Increase in temperature	Within class B
Voltage/frequency	

Bredel Variable Frequency Drive (VFD) (optional)

The Bredel Variable Frequency Drive (VFD) has been preprogrammed and only needs to be connected to the mains.

RFI filter	Integrated RFI filter B (industrial applications).
Control	Manual control for setting the speed and the keys for starting forward, stop and starting reverse. More options are available.
Protection class	IP55
Mains power supply	Several types are available; the choice depends on the power and the local electricity grid: <ul style="list-style-type: none">• 200-240 V \pm 10%; 50/60 Hz \pm 5%; 1 ph• 200-240 V \pm 10%; 50/60 Hz \pm 5%; 3 ph• 400-480 V \pm 10%; 50/60 Hz \pm 5%; 3 ph

11.2 Parts list

Overview

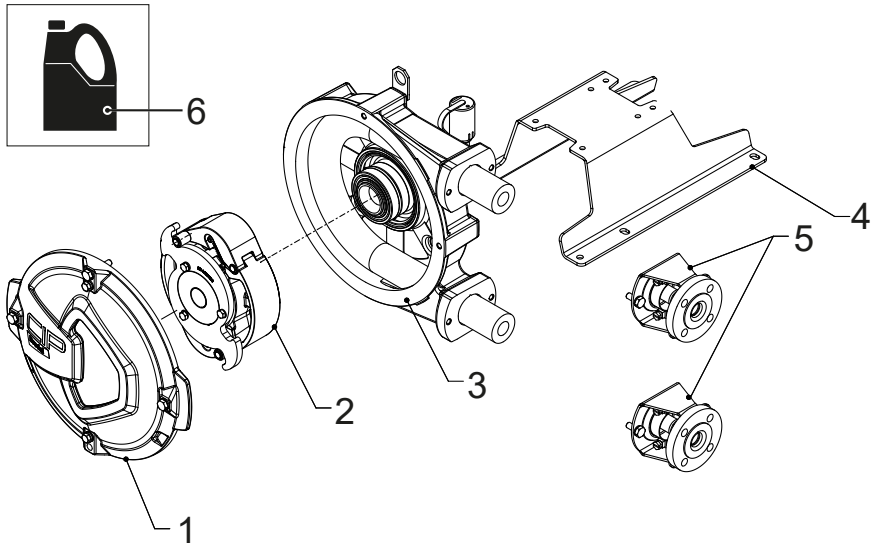

Pos.	Description
1	Cover assembly. Refer to "Cover assembly" on the next page
2	Rotor assembly. Refer to "Rotor assembly" on page 85
3	Pump housing assembly. Refer to "Pump housing assembly" on page 87
4	Pump support assembly. Refer to "Pump support assembly" on page 89
5	Flange assembly. Refer to "Flange assembly" on page 90
6	Lubricant. Refer to "Lubricant" on page 92

Cover assembly

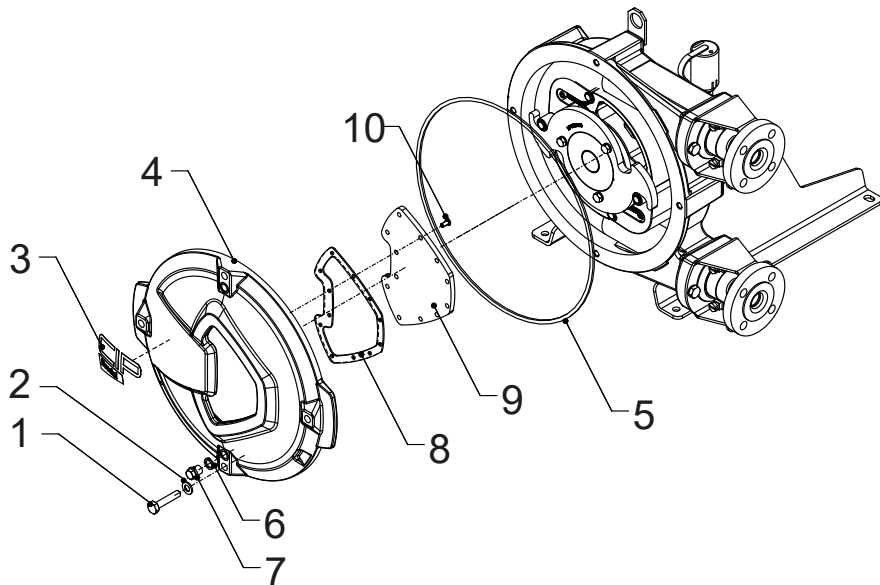

Pos.	Qty.	Description	Product code	
			Bredel CIP25	Bredel CIP32
1	4	Bolt, hex. head	28-F502047	28-F502046
2	4	Washer	28-F523013	28-F523013
3	1	Sticker	28-1009290	28-1009304
4	1	Cover	28-1009263	28-1009260
5	1	Quad ring	28-225123	28-232123
6	2	Gasket	28-S120131	28-S120131
7	2	Drain plug	28-F911502	28-F911502
8	1	Gasket	28-1009289	28-1009303
9	1	Inspection window	28-1009288	28-1009302
10	12	Round head screw	28-F552535	28-F552535

Rotor assembly

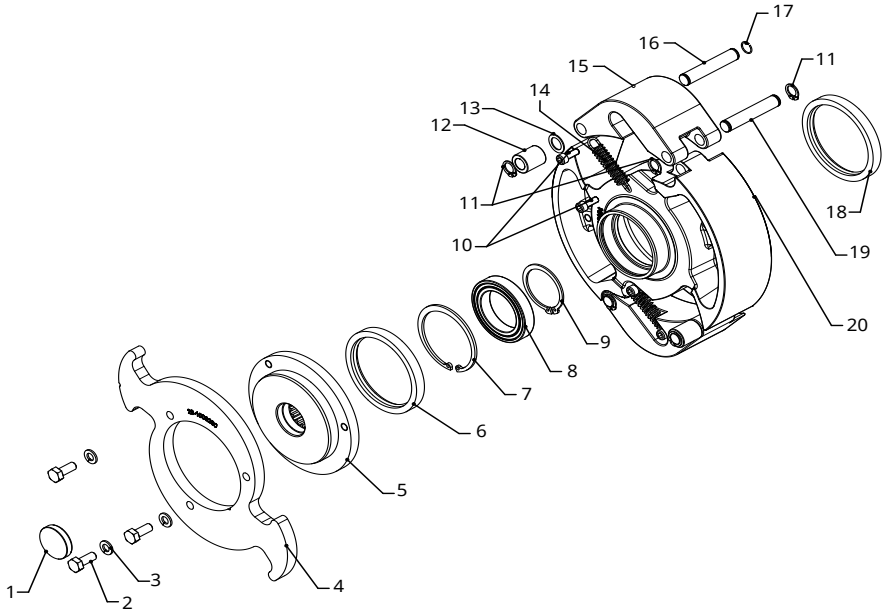

Pos.	Qty.	Description	Product code	
			Bredel CIP 25	Bredel CIP 32
1	1	Sealing cap	28-S417007	28-S417007
2	3	Actuation disc bolt	28-F504054	28-F504054
3	3	Actuation disc washer	28-F532009	28-F532009
4	1	Actuation disc	28-1009280	28-1009295
5	1	Drive shaft	28-1009279	28-1009279
6	1	Seal	28-1007612	28-1007612
7	1	Circlip	28-F544044	28-F544044
8	1	Bearing	28-1009287	28-1009287
9	1	Circlip	28-F543034	28-F543034
10	4	Bolt (for spring)	28-F505056	28-F505056
11	6	Circlip	28-F543009	28-F543013
12	2	Roller bush L	28-1009283	28-1009298
		Roller bush M	28-1009284	28-1009299
		Roller bush H	28-1009285	28-1009300
		Roller bush X	28-1009286	28-1009301
13	2	Shim ring	28-1009393	28-1009394
14	2	Spring	28-1009293	28-1009306
15	2	Pressing shoe	28-1009278	28-1009294
16	2	Actuation pin	28-1009282	28-1009297
17	2	Circlip	28-F546004	28-F546013
18	1	Wear ring	28-29120202	28-29120202
19	2	Pivot pin	28-1009281	28-1009296

Pos.	Qty.	Description	Product code	
			Bredel CIP 25	Bredel CIP 32
20	1	Base rotor	28-1009164	28-1009254

Pump housing assembly

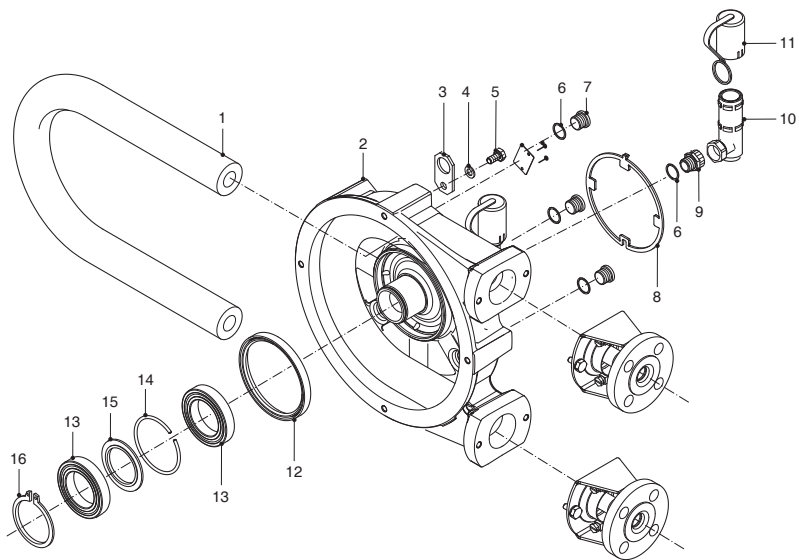

Pos.	Qty	Description	Product code	
			Bredel CIP25	Bredel CIP32
1	1	Hose NR Metering	28-1007881	28-1007882
	1	Hose NR Transfer	28-1000059	28-1000061
	1	Hose NBR	28-025040	28-032040
	1	Hose CSM	28-025070	28-032070
	1	Hose EPDM	28-025075	28-032075
	1	Hose NBR Food	28-025061	28-032061
	1	Hose F-NBR	28-025065	28-025065
2	1	Pump housing	28-225101	28-232101
3	1	Lifting strip	28-29065361	28-29065361
4	1	Washer, Spring Lock	28-F336012	28-F336012
5	1	Bolt	28-F111096	28-F111096
6	4	Gasket	28-F342027	28-F342027
7	3	Stop	28-F901004	28-F901004
8	1	Seal	28-225114	28-232114
9	1	Crimp connector	28-F602504	28-F602504
10	1	Breather	28-29095146	28-29095146
11	1	Breather cap	28-29065223	28-29065223
12	1	Seal	28-S212411	28-S212411
13	2	Bearing	28-B141260	28-B141260
14	1	Retaining circlip	28-29095297	28-29095297
15	1	Spacer ring	28-29085201	28-29085201
16	1	Retaining circlip	28-F343049	28-F343049

Pump support assembly

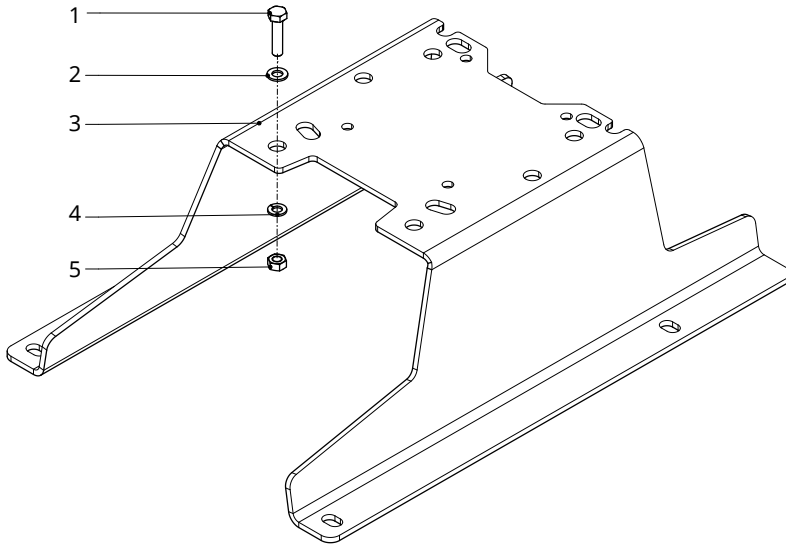

Pos.	Qty	Description	Product code	
			Bredel CIP25	Bredel CIP32
1	4	Bolt	28-F111076	28-F101080
2	4	Washer	28-F322012	28-F322015
3	1	Pump support	28-225106	28-232106
			28-29600106	28-29600106
			28-29600107	28-29600107
4	4	Spring washer	28-F336011	28-F336013
5	4	Nut	28-F301006	28-F301008

Flange assembly

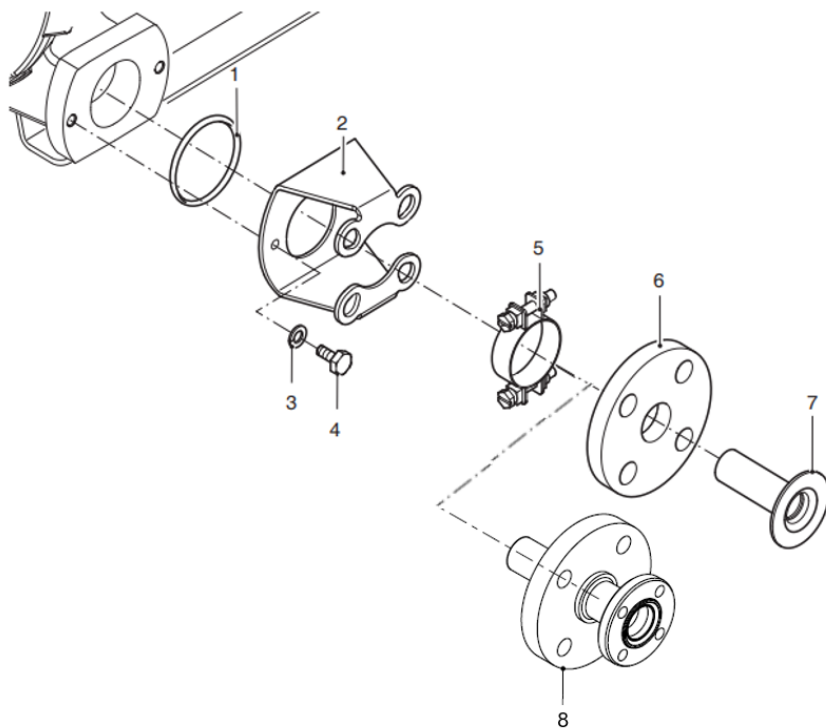

Pos.	Qty	Description	Product code	
			Bredel CIP25	Bredel CIP32
1	2	O-ring	28-S112231	28-S112271
2	2	Flange bracket, Steel	28-225197	28-232197
	2	Flange bracket, SS	28-225197A	28-232197A
3	4	Washer, Spring Lock	28-F336012	28-F336012
4	4	Bolt	28-F111096	28-F111096
5	2	Hose clamp	28-C122004	28-C121006
6	2	Flange, DIN Steel	28-025198	28-032198
	2	Flange, DIN SS	28-225199	28-232199
	2	Flange, ANSI Steel	28-025198A	28-032198A
	2	Flange, ANSI SS	28-225199A	28-232199A
7	2	Insert, SS	28-025186	28-032186
	2	Insert, PVC	28-025187	28-032187
	2	Insert, PP	28-025189	28-032189
	2	Insert PVDF	28-025190	28-032190
8	2	DIN 11851 & DIN11887	28-1003289	28-1003602
	2	DIN 11864 1 form A series A	28-1003589	28-1003606
	2	DIN 11864 2 form A series A	28-1003591	28-1003608
	2	Triclamp DIN 32676	28-1003120	28-1003604
	2	IDF	28-1003594	28-1003611
	2	RJT	28-1003596	28-1003613
	2	SMS	28-1003598	28-1003615

Revolution counter assembly

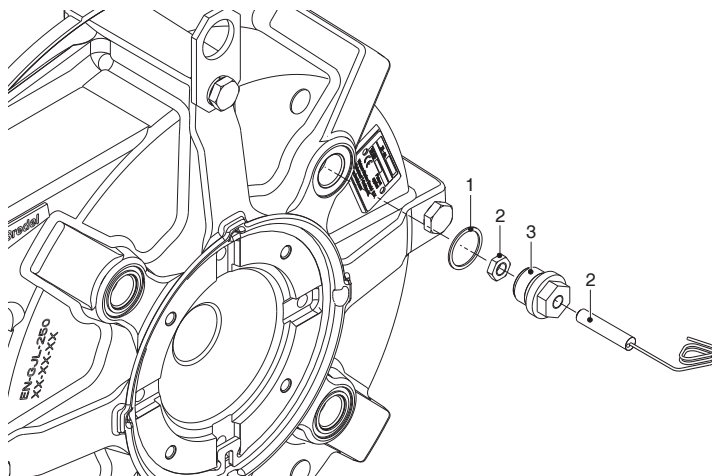

Pos.	Qty.	Description	Product code	
			Bredel CIP25	Bredel CIP32
1	1	Gasket	28-F342027	28-F342027
2	1	Revolution counter	28-29040462	28-29040462
3	1	Adapter	28-29027248	28-29027248

Lubricant

Bredel CIP25

Pos.	Qty.	Description	Product code
-	1	2 l can Bredel Genuine Hose Lubricant	28-902143

Bredel CIP32

Pos.	Qty.	Description	Product code
-	1	3 l can Bredel Genuine Hose Lubricant	28-908143
-	1	0.5 l can Bredel Genuine Hose Lubricant	28-901143

12 Safety form

Product Use and Decontamination Declaration

In compliance with the Health and Safety Regulations, the user is required to declare those substances that have been in contact with the item(s) you are returning to Watson-Marlow Bredel B.V. or any of its subsidiaries or distributors. Failure to do so will cause delays in servicing the item or in issuing a response. Therefore, **please complete this form** to make sure we have the information before receipt of the item(s) being returned. A completed copy must be attached to **the outside of the packaging** containing the item(s). You, the user, are responsible for cleaning and decontaminating the item(s) before returning them.

Please complete a separate Decontamination Certificate for each item returned.

RGK/KBR no......

1 Company
 Address
 Telephone Postal code
 Fax number

2 Product

2.1 Serial Number

2.2 Has the Product been used?

YES NO

If yes, please complete all the following paragraphs.

If no, please complete paragraph 5 only

3 Details of substances pumped

3.1 Chemical Names

a)
 b)
 c)
 d)

3.2 Precautions to be taken in handling these substances:

a)
 b)
 c)
 d)

3.3 Action to be taken in the event of human contact:

a)
 b)
 c)
 d)

3.4 Cleaning fluid to be used if residue of chemical is found during servicing;

a)
 b)
 c)
 d)

4 I hereby confirm that the only substances(s) that the equipment specified has pumped or come into contact with are those named, that the information given is correct, and the carrier has been informed if the consignment is of a hazardous nature.

5 Signed

Name

Position

Date

Note:

To assist us in our servicing please describe any fault condition you have witnessed.

.....

