

Flexicon 620DiN / 620Di pumps



Contents

1	Declaration of conformity	3	18	Calibrate	50
2	Declaration of incorporation	4	19	Setup	54
3	Five-year warranty	5	19.1	Dosing	55
4	When you unpack your pump	6	19.2	Display	57
5	Information for returning pumps	6	19.3	Pump I/D	58
6	Peristaltic pumps - an overview	7	19.4	Baud	58
7	Safety notes	8	19.5	Stop bits	59
8	Pump specifications	10	19.6	Xon/Xoff	59
8.1	Pressure capability	15	19.7	Flow units	60
8.2	Dimensions	16	19.8	Date and time	61
9	Good pump installation practice	17	19.9	Max key operation	61
9.1	General recommendations	17	19.10	Outputs	62
9.2	Do's and do not's	18	19.11	Remote stop	64
10	Connecting this product to a power supply	19	19.12	Auto-restart	66
11	Start-up check list	20	19.13	Set maximum allowed speed	67
12	Switching the pump on for the first time	20	19.14	Set minimum allowed speed	67
13	Switching the pump on in subsequent power cycles (if not in auto-restart mode)	22	19.15	Scrolling	68
14	Manual operation	23	19.16	Backlight	68
14.1	Keypad functions	23	19.17	ROM	69
14.2	Speed	25	19.18	Pin out details	69
14.3	Direction	25	19.19	Language	71
14.4	Keypad lock	26	19.20	Defaults	71
14.5	Keypad beep	26	19.21	Beep	72
14.6	Manual operation and remote digital inputs and outputs	26	19.22	Security code	73
14.7	Backlight	27	19.23	Exit	74
14.8	Auto-restart	27	20	Automatic control wiring using the 620N module	75
15	Main menu	28	20.1	620N module removal and replacement	75
15.1	Keypad functions when not in manual mode	28	20.2	Wiring up	76
15.2	Main menu entry	29	20.3	Run/stop input	81
16	PIN-secure process protection	31	20.4	Direction input	81
17	Dose	32	20.5	Dose input	81
17.1	Setting a dispense program	33	20.6	Leak detection input	82
17.2	Loading a stored dispense program	41	20.7	Outputs 1, 2, 3, 4	82
17.3	Starting a dispense program	42	20.8	Supply voltages	83
17.4	User and batch sequence	43	20.9	RS485 input	83
17.5	While a dispense program is running	44	21	Automatic control wiring without the 620 module	84
17.6	To stop or pause a dispense program	47	21.1	Run/stop input	87
			21.2	Direction input	87
			21.3	Dose input	88
			21.4	Leak detection input	89
			21.5	Pump status outputs	90

21.5.1 Logic output 1	90	28 620RE, 620RE4 and 620R	
21.5.2 Logic output 2	91	performance data	112
21.5.3 Logic output 3	92	28.1 620RE, 620RE4 and 620R	
21.5.4 Logic output 4	92	flow rates	113
21.6 Supply voltages	93	29 620RE, 620RE4 and 620R	
22 Network control and operation	94	continuous tubing product codes	115
22.1 RS232 and RS485		30 620RE and 620RE4 LoadSure	
command strings	95	product codes	116
23 Connecting a computer	97	31 620L and 620LG pumpheads	117
24 Troubleshooting	98	31.1 620L and 620LG	
24.1 Error codes	99	key safety information	117
25 Drive maintenance	100	31.2 620L and 620LG guarding	117
26 Drive spares	100	31.3 620L and 620LG	
27 620RE, 620RE4 and 620R		pumping conditions	118
pumpheads	101	31.4 620L and 620LG	
27.1 620RE, 620RE4 and 620R		removal and installation	118
Key safety information	101	31.5 620L and 620LG	
27.2 620RE, 620RE4 and 620R		tube loading	120
safe-guarding	101	31.6 620L and 620LG care	
27.3 620RE, 620RE4 and 620R		and maintenance	121
pumping conditions	102	31.7 620L and 620LG	
27.4 620RE, 620RE4 and 620R		track adjustment	121
pump installation	102	31.8 620L and 620LG	
27.5 620RE, 620RE4 and 620R		pumphead spares	122
general operation	103	32 620L and 620LG	
27.6 620RE and 620RE4		performance data	123
tube element loading	104	32.1 620L and 620LG	
27.7 620R continuous		flow rates	123
tube loading	105	32.2 620L tubing codes	124
27.8 620RE, 620RE4 and 620R		32.3 620LG element codes	125
tube element or		33 Pumping accessories	125
continuous tube removal	106	34 Trademarks	126
27.9 620RE, 620RE4 and 620R		35 Warning not to use pumps in	
maintenance	106	patient-connected applications	126
27.10 620RE, 620RE4 and 620R		36 Publication history	126
CIP and SIP	109	37 Decontamination certificate	127
27.11 620RE, 620RE4 and 620R			
pumphead spares	110		

1 Declaration of conformity

Printed conformance documents are supplied within product packaging.

2 Declaration of incorporation

Available on request

3 Five-year warranty

520 cased pumps, 620 cased pumps and 720 cased pumps

For any 520, 620 or 720 cased pump purchased after 1 January 2007, Watson-Marlow Limited ("Watson-Marlow") warrants, subject to the conditions and exceptions below, through either Flexicon, its subsidiaries, or its authorised distributors, to repair or replace free of charge, any part of the product which fails within five years of the day of manufacture of the product. Such failure must have occurred because of defect in material or workmanship and not as a result of operation of the product other than in normal operation as defined in this pump manual.

Flexicon shall not be liable for any loss, damage, or expense directly or indirectly related to or arising out of the use of its products, including damage or injury caused to other products, machinery, buildings, or property, and Watson-Marlow shall not be liable for consequential damages, including, without limitation, lost profits, loss of time, inconvenience, loss of product being pumped, and loss of production. This warranty does not obligate Watson-Marlow to bear any costs of removal, installation, transportation, or other charges which may arise in connection with a warranty claim.

Conditions of and specific exceptions to the above warranty are:

Conditions

- Products must be returned by pre-arrangement, carriage-paid, to Watson-Marlow, or a Watson-Marlow approved service centre.
- All repairs or modifications must have been made by Watson-Marlow Limited, or a Watson-Marlow approved service centre or with the express permission of Watson-Marlow.
- Warranties purporting to be on behalf of Watson-Marlow made by any person, including representatives of Watson-Marlow, its subsidiaries, or its distributors, which do not accord with the terms of this warranty shall not be binding upon Flexicon unless expressly approved in writing by a Director or Manager of Flexicon.

Exceptions

- The warranty shall not apply to repairs or service necessitated by normal wear and tear or for lack of reasonable and proper maintenance.
- All tubing and pumping elements as consumable items are excluded.
- Products which, in the judgment of Watson-Marlow, have been abused, misused, or subjected to malicious or accidental damage or neglect are excluded.
- Electrical surge as a cause of failure is excluded.
- Chemical attack is excluded
- All pumphead rollers are excluded.
- The 620R family of pumpheads are excluded from all warranty when pumping above 2 bar while above 165rpm.
- Pumpheads from the 313/314 and the Microcassette ranges and any 701 extension pumpheads are excluded and retain their one-year standard pumphead warranty. The drive they are attached to is subject to the five-year warranty as set out here.
- Ancillaries such as leak detectors are excluded.

4 When you unpack your pump

Unpack all parts carefully, retaining the packaging until you are sure all components are present and in good order. Check against the components supplied list, below.

Packaging disposal

Dispose of packaging materials safely, and in accordance with regulations in your area. The outer carton is made of corrugated cardboard and can be recycled.

Inspection

Check that all components are present. Inspect components for damage in transit. If anything is missing or damaged, contact your distributor immediately.

Components supplied

620Di and 620DiN pumps are available in two forms, dedicated to either 620R series pumpheads or 620L series pumpheads. Pumps are supplied as:

- Dedicated 620R pump drive unit fitted with 620R, 620RE or 620RE4 pumphead (see 8. Pump specifications); OR: Dedicated 620L pump drive unit fitted with 620L or 620LG pumphead (see 8. Pump specifications)
- A 620DiN includes the 620N module providing pump ingress protection to IP66 (substantially equivalent to NEMA 4X indoor use only).
Note: the module is attached for transit, but must be removed to allow wiring up, voltage selection and fuse inspection and then re-affixed before the pump is operated.
- The designated mains power lead for your pump
- Safety information booklet
- Quick Start manual

Note: Some versions of this product will include components different from those listed above. Check against your purchase order.

Storage

This product has an extended shelf life. However, care should be taken after storage to ensure that all parts function correctly. Users should be aware that the pump contains a battery with an unused life of seven years. Long-term storage is not recommended for peristaltic pump tubing. Please observe the storage recommendations and use-by dates which apply to tubing you may wish to bring into service after storage.

5 Information for returning pumps

Equipment which has been contaminated with, or exposed to, body fluids, toxic chemicals or any other substance hazardous to health must be decontaminated before it is returned to Watson-Marlow or its distributor.

A certificate included at the rear of these operating instructions, or signed statement, must be attached to the outside of the shipping carton. This certificate is required even if the pump is unused.

If the pump has been used, the fluids that have been in contact with the pump and the cleaning procedure must be specified along with a statement that the equipment has been decontaminated.

6 Peristaltic pumps - an overview

Peristaltic pumps are the simplest pump, with no valves, seals or glands to clog or corrode. The fluid contacts only the bore of a tube, eliminating the risk of the pump contaminating the fluid, or the fluid contaminating the pump. Peristaltic pumps can run dry.

How they work

A compressible tube is squeezed between a roller and a track on an arc of a circle, creating a seal at the point of contact. As the roller advances along the tube, the seal also advances. After the roller has passed, the tube returns to its original shape, creating a partial vacuum which is filled by fluid drawn from the inlet port.

Before the roller reaches the end of the track, a second roller compresses the tube at the start of the track, isolating a packet of fluid between the compression points. As the first roller leaves the track, the second continues to advance, expelling the packet of fluid through the pump's discharge port. At the same time, a new partial vacuum is created behind the second roller into which more fluid is drawn from the inlet port.

Backflow and siphoning do not occur, and the pump effectively seals the tube when it is inactive. No valves are needed.

The principle may be demonstrated by squeezing a soft tube between thumb and finger and sliding it along: fluid is expelled from one end of the tube while more is drawn in at the other.

Animal digestive tracts function in a similar way.

Suitable applications

Peristaltic pumping is ideal for most fluids, including viscous, shear-sensitive, corrosive and abrasive fluids, and those containing suspended solids. They are especially useful for pumping operations where hygiene is important.

Peristaltic pumps operate on the positive displacement principle. They are particularly suitable for metering, dosing and dispensing applications. Pumps are easy to install, simple to operate and inexpensive to maintain.

7 Safety notes

In the interests of safety, this pump and the tubing selected should only be used by competent, suitably trained personnel after they have read and understood this manual, and considered any hazard involved. If the pump is used in a manner not specified by Watson-Marlow Ltd, the protection provided by the pump may be impaired.

Any person who is involved in the installation or periodic maintenance of this equipment should be suitably skilled or instructed and supervised using a safe system of work. In the UK this person should also be familiar with the Health and Safety at Work Act 1974. The safety of any system incorporating the equipment is the responsibility of the assembler of the system.



This symbol, used on the pump and in this manual, means: Caution, risk of electric shock.



This symbol, used on the pump and in this manual, means: Caution, refer to accompanying documents.



This symbol, used on the pump and in this manual, means: Do not allow fingers to contact moving parts.



There is a user-replaceable type T 5A H 250V fuse in the fuseholder in the centre of the switchplate at the back of the pump.

The 620N module must be removed, if a 620DiN, to allow access to the switchplate. See 20.1 620N module removal and replacement. There are thermal fuses within the pump which self-reset within 60 seconds; if they trip an error code is displayed. This pump contains no user-serviceable fuses or parts.



Fundamental work with regard to lifting, transportation, installation, starting-up, maintenance and repair should be performed by qualified personnel only. The unit must be isolated from mains power while work is being carried out.

There are moving parts inside the pumphead. Before opening the tool-unlockable pumphead guard, ensure that the following safety directions are followed.

- Ensure that the pump is isolated from the mains power.
- Ensure that there is no pressure in the pipeline.
- If a tube failure has occurred, ensure that any fluid in the pumphead has been allowed to drain to a suitable vessel, container or drain.
- Ensure that protective clothing and eye protection are worn if hazardous fluids are pumped.
- Primary operator protection from rotating parts of the pump is provided by the pumphead safeguard. Note that safeguards differ, depending on the type of pumphead. See the pumphead sections of this manual, 27 and 31.
- Secondary operator protection from rotating parts of the pump is provided by electrical interlocking of the pumphead guard. This function will stop the pump if the guard is inadvertently opened while the pump is running. For details of permissible pumphead orientations, see the pumphead sections of this manual, 27 and 31.

This pump must be used only for its intended purpose. The pump must be accessible at all times to facilitate operation and maintenance. Access points must not be obstructed or blocked. The pump's mains plug is the disconnecting device (for isolating the motor drive from the mains supply in an emergency). Do not position the pump so that it is difficult to disconnect the mains plug. Do not fit any devices to the drive unit other than those tested and approved by Watson-Marlow. Doing so could lead to injury to persons or damage to property for which no liability can be accepted.



This product does not comply with the ATEX directive and must not be used in explosive atmospheres.

If hazardous fluids are to be pumped, safety procedures specific to the particular fluid and application must be put in place to protect against injury to persons.

The following minimum PPE will be required during specific tasks:

1. Safety glasses
2. Safety boots
3. Gloves chemically compatible with the chemicals being pumped

A risk assessment by a responsible person must be done to identify:

- Suitability of PPE for the application
- If additional PPE is required prior to use or for specific tasks

The exterior surfaces of the pump may get hot during operation. Do not take hold of the pump while it is running. Let it cool after use before handling it.

No attempt should be made to run the drive without a pumphead fitted.

The pump weighs more than 18kg (the exact weight depends on model and pump-head—see 8 Pump specifications). Lifting should be performed according to standard Health and Safety guidelines. Finger recesses are built into the sides of the lower shell for convenience in lifting; in addition, the pump can conveniently be lifted by grasping the pumphead and (where fitted) the 620N module at the rear of the pump.

8 Pump specifications

DiN

Labels fixed to the rear of the pump contain manufacturer and contact details, product reference number, serial number and model details.

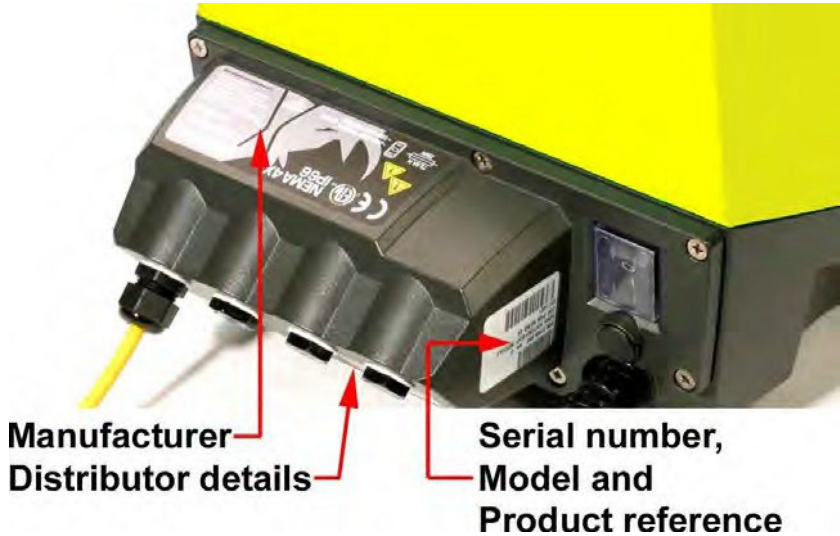

DiN, Di

The same information is carried on the drive's backplate, accessible when the 620N module is removed. The picture below is how a 620Du looks from the box. The number of connectors varies according to the model.

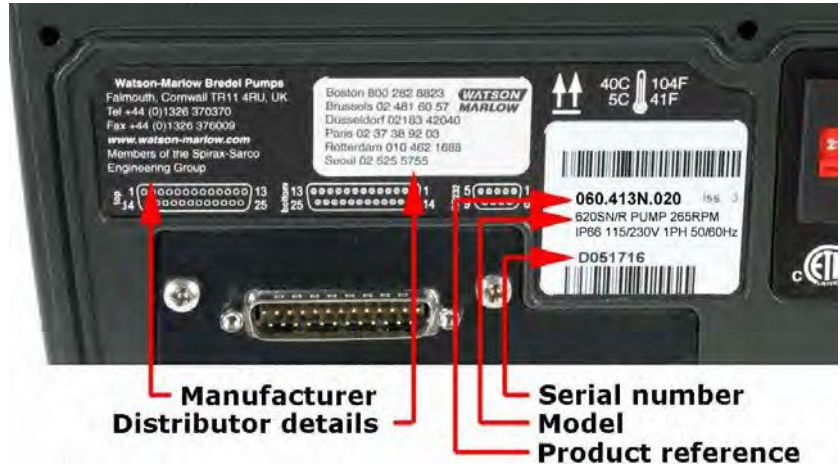

DiN

620DiN, IP66 NEMA 4X model

This pump can be controlled from the keypad or remotely. It features:

Manual control

Speed adjustment; run and stop; direction control; "max" key for rapid priming.

Remote control

The pump can be digitally controlled with a contact closure or logic input signal to operate the pump.

Outputs

There are four 24V relay status outputs which can be configured in software for a variety of pump parameters

Calibration

Full calibration, plus default figures for a range of pumpheads and tubes.

Calibration dose facility.

RS485 serial communications

Full pump control from a PC or other controller with the ability to network up to 32 pumps. **Computer recording of dispensed batches is not possible under RS485.**

Dispensing feature

Batch or single-dose dispensing, including dose size and number, interval, start and end ramp and drip control.

Guard switch

Primary operator protection from rotating parts of the pump is provided by the fixed guard. Secondary operator protection from rotating parts of the pump is provided by indicator-only switching of the pumphead guard.

PIN-secure process protection

Two levels of control protection: main PIN code and user PIN code.

Di

620Di, IP31 model

This pump can be controlled from the keypad or remotely. It features:

Manual control

Speed adjustment; run and stop; direction control; "max" key for rapid priming.

Remote control

The pump can be digitally controlled with a contact closure or logic input signal to operate the pump.

Outputs

There are four 24V relay status outputs which can be configured in software for a variety of pump parameters

Calibration

Full calibration, plus default figures for a range of pumpheads and tubes. Calibration dose facility.

RS232 serial communications

Full pump control from a PC or other controller with the ability to network up to 32 pumps. **A computer can be connected to the pump to make (and print) records of dispensed batches.**

Dispensing feature

Batch or single-dose dispensing, including dose size and number, interval, start and end ramp and drip control.

Guard switch

Primary operator protection from rotating parts of the pump is provided by the fixed guard. Secondary operator protection from rotating parts of the pump is provided by indicator-only switching of the pumphead guard.

PIN-secure process protection

Two levels of control protection: main PIN code and user PIN code.

IP (Ingress Protection) and NEMA definitions

IP		NEMA
1st Digit	2nd Digit	
3 Protected against ingress of solid objects with a diameter of more than 2.5mm. Tools, wires etc with a thickness of more than 2.5mm are prevented from approach	1 Protection against dripping water falling vertically. No harmful effect must be produced	2 Indoor use to provide a degree of protection against limited amounts of falling water and dirt
5 Protected against harmful dust deposits. Ingress of dust is not totally prevented but the dust must not enter in sufficient quantity to interfere with satisfactory operation of the equipment. Complete protection against contact	5 Protection against water projected from a nozzle against the equipment (enclosure) from any direction. There must be no harmful effect (water jet)	12 Indoor use to provide a degree of protection against dust, falling dirt and dripping, non-corrosive liquids
		13 Indoor use to provide a degree of protection against dust and spraying water, oil and non-corrosive coolants
6 Protection against ingress of dust (dust-tight). Complete protection against contact	6 Protection against heavy seas or powerful water jets. Water must not enter the equipment (enclosure) in harmful quantities (splashing over)	4X Indoor or outdoor use to provide a degree of protection against splashing water, windblown dust and rain, hose-directed water; undamaged by the formation of ice on the enclosure. (Resist corrosion: 200-hour salt spray)

DiN, Di

Unit weights

	Drive only	+ 620R, 620RE	+ 620RE4	+ 620L, 620LG
IP31	16.5kg, 36lb 6oz	19.6kg, 43lb 3oz	20.1kg, 44lb 5oz	24.3kg, 53lb 9oz
IP66 NEMA 4X	17.4kg, 38lb 6oz	20.5kg, 45lb 3oz	21.0kg, 46lb 5oz	25.2kg, 55lb 9oz

Pump specifications

Control range (turndown ratio)	0.1-265rpm (2650:1)
Supply voltage/frequency	Filtered 100-120V/200-240V 50/60Hz 1ph
Maximum voltage fluctuation	±10% of nominal voltage. A well regulated electrical mains supply is required along with cable connections conforming to the best practice of noise immunity
Installation category (overvoltage category)	II
Power consumption	250VA
Full load current	<1.1A at 230V; <2.2A at 115V
Eprom version	Accessible through pump software
Enclosure rating - 620DiN	620DiN: IP66 substantially equivalent to NEMA 4X indoor use only*
Enclosure rating - 620Di	620Di: IP31 substantially equivalent to NEMA 2 indoor use only*
Pumphead options (620R models)	620R, 620RE, 620RE4
Pumphead options (620L models)	620L, 620LG
Operating temperature range	5C to 40C, 41F to 104F
Storage temperature range	-25C to 65C, -13F to 149F
Maximum altitude	2,000m, 6,560ft
Maximum humidity (non-condensing) (620Di)	80% up to 31C, 88F, decreasing linearly to 50% at 40C, 104F
Humidity (condensing) (620DiN)	10% - 100% RH
Weight	See table on previous page
Noise	<70dB(A) at 1m

* Protect from prolonged UV exposure.

Standards

EC harmonised standards	Safety requirements for electrical equipment for measurement, control and laboratory use: BS EN 61010-1 incorporating A2 Category 2, Pollution degree 2
	Degrees of protection provided by enclosures (IP code): BS EN 60529
	Conducted emissions: BS EN 55011 Class A
	Radiated emissions: BS EN 55011 Class A
	Electrostatic discharge: BS EN 61000-4-2
	Radiated RF immunity: BS EN 61000-4-3
	Fast transient burst: BS EN 61000-4-4 A1 and A2, Level 3 (2kV)
	Surge immunity: BS EN 61000-4-5
	Conducted RF immunity: BS EN 61000-4-6
	Voltage dips and interruptions: BS EN 61000-4-11
	Mains harmonics: BS EN 61000-3-2
	UL 61010A-1
Other standards	CAN/CSA-C22.2 No 61010-1
	Conducted emissions FCC 47CFR, Part 15.107

8.1 Pressure capability

0 – 4bar higher pressure pumping:

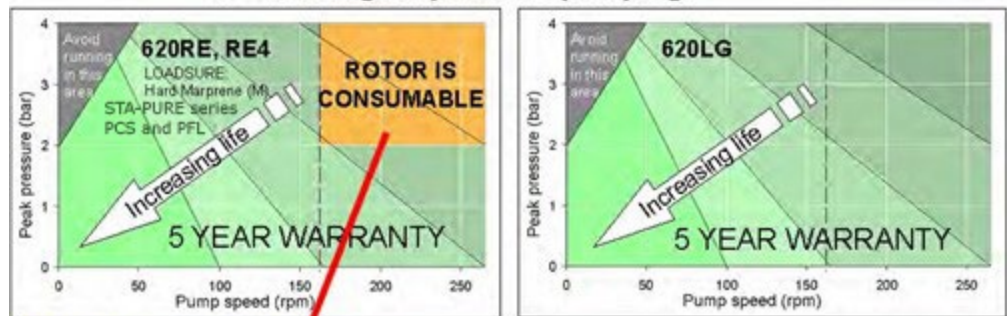

Over 165rpm and 2bar 620RE rotor is consumable
 ⚠ to accept

This pump's default running speed is 165rpm. It can be run at any speed up to 265rpm. Please note, however:

- **The 620RE and 620RE4 rotor warranty is limited to 2 bar from 165rpm to 265rpm.**
- A warning is displayed when the user sets the speed above 165rpm.
Note: Applies to 620RE MarkII and 620RE4 MarkII pumpheads only. (The 620LG is not limited).
- The pump's software records the duration of operation above 165rpm.

0 – 2bar pressure pumping:

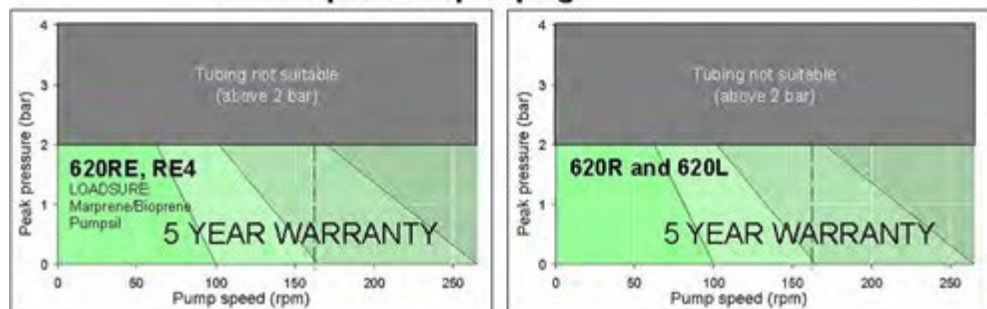

8.2 Dimensions

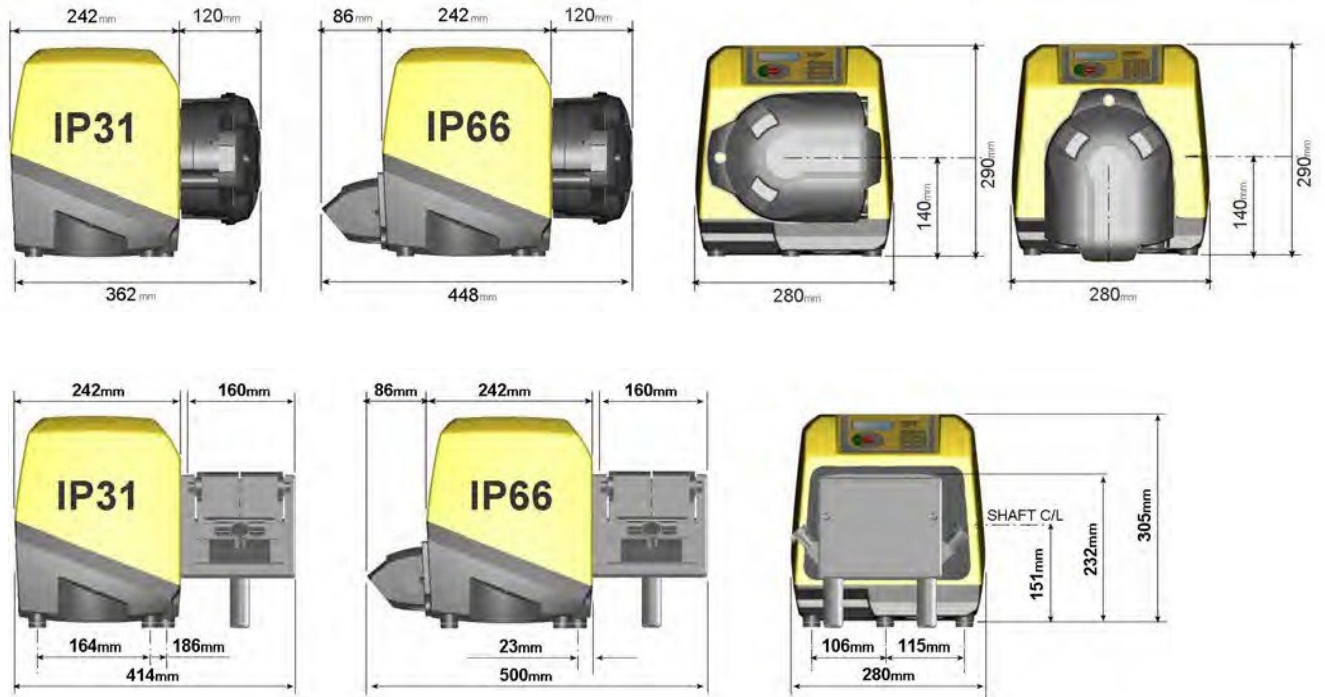

9 Good pump installation practice

9.1 General recommendations

Position

A correctly engineered installation will promote long tube life. Site the pump on a flat, horizontal, rigid surface, free from excessive vibration, to ensure correct lubrication of the gearbox. Allow a flow of air around the pump to ensure that heat can be dissipated. Ensure that the temperature around the pump does not exceed 40C.

Do not stack other 620 pumps on top of this pump. It is, however, acceptable to stack other equipment on the upper surface of the 620 (as long as the ambient temperature does not exceed 40C).

Emergency disconnection

The pump's mains plug is the disconnecting device (for isolating the motor drive from the mains supply in an emergency). Do not position the pump so that it is difficult to disconnect the mains plug. The **STOP** key on the keypad will always stop the pump. However, it is recommended that a suitable local emergency stop device is fitted into the mains supply to the pump.

Valves

Peristaltic pumps are self-priming and self-sealing against backflow. No valves are required in inlet or discharge lines. Valves in the process flow must be opened before the pump operates. Users are advised to fit a pressure relief device between the pump and any valve on the discharge side of the pump to protect against damage caused by accidental operation with the discharge valve closed.

The pump may be set up so that the direction of rotor rotation is clockwise or counter-clockwise, whichever is convenient.

Tubing materials: run-in advice

GORE® STA-PURE Series PFL, GORE® STA-PURE Series PCS and Marprene TM tubing are hard to compress when new. When using tubing made of these materials, the first five pumphead revolutions should be at a speed of 10rpm or greater. If the pump is run slower, the safety system built into pump drive's software may cause it to stop and display an over-current error message.

Pressure advice

In most circumstances, rotor and tube life are maximised if the pumphead is run slowly, particularly when pumping at high pressure. However, to maintain performance at pressures above 2 bar, avoid running the pumphead below 50rpm. If low-flow, high-pressure operation is necessary, switching to a smaller tube is recommended.

9.2 Do's and do not's

Do not build a pump into a tight location without adequate airflow around the pump.

Do not position the pump so that it is difficult to disconnect the mains plug. The power input plug for the pump is also the disconnecting device for isolating the motor drive from the power supply in an emergency.

Do not strap the control and mains power cables together.

Do ensure that when the 620N watertight module is fitted the seals are intact and properly located. Ensure that the holes for cable glands are properly sealed to maintain the IP66 / NEMA 4X rating.

Do keep delivery and suction tubes as short and direct as possible - though ideally not shorter than 1m - and follow the straightest route. Use bends of large radius: at least four times the tubing diameter. Ensure that connecting pipework and fittings are suitably rated to handle the predicted pipeline pressure. Avoid pipe reducers and lengths of smaller bore tubing than the pumphead section, particularly in pipelines on the suction side. Any valves in the pipeline (not usually needed) must not restrict the flow. Any valves in the flow line must be open when the pump is running.

Do use suction and delivery pipes equal to or larger than the bore of the tube in the pumphead. When pumping viscous fluids use pipe runs with a bore several times larger than the pump tube.

Do ensure that on longer tube runs at least 1m of smooth bore flexible tubing is connected to the inlet and discharge port of the pumphead to help to minimize impulse losses and pulsation in the pipeline. This is especially important with viscous fluids and when connecting to rigid pipework.

Do site the pump at or just below the level of the fluid to be pumped if possible. This will ensure flooded suction and maximum pumping efficiency.

Do keep the pumphead track and all moving parts clean and free from contamination and debris.

Do run at slow speed when pumping viscous fluids (though see Pressure advice in 9.1 General recommendations). Flooded suction will enhance pumping performance in all cases, particularly for materials of a viscous nature.

Do recalibrate after changing pump tubes, fluid, or any connecting pipework. It is also recommended that the pump is recalibrated periodically to maintain accuracy.

IP66 / NEMA 4X models may be hosed down, but should not be immersed. Protect from prolonged UV exposure.

IP31 models may be wiped with a damp cloth, but should not be hosed or immersed. The front of IP31 models is further protected against light spillages onto the pump.

When using Marprene or Bioprene continuous tubing, do re-tension the tube after the first 30 minutes of running.

Tube selection: The chemical compatibility lists published in Watson-Marlow publications are guides. If in doubt about the compatibility of a tube material and the duty fluid, request a Watson-Marlow tube sample card for immersion trials.

10 Connecting this product to a power supply

A well regulated electrical mains supply is required along with cable connections conforming to the best practice of noise immunity. It is not recommended to site these drives alongside "dirty" electrical mains supplies such as 3-phase contactors and inductive heaters without special attention being paid to unacceptable mains-borne noise.



The voltage selector is mounted in the switchplate at the rear of the pump, protected from water by the 620N module (620DiN). The module must be removed to allow access to the switchplate. See 20.1 620N module removal and replacement. Set the voltage selector to 115V for 100-120V 50/60Hz supplies or 230V for 200-240V 50/60Hz supplies. Always check the voltage selector switch before connecting the mains supply. Make suitable connection to an earthed, single-phase mains electricity supply.



We recommend using commercially available supply voltage surge suppression where there is excessive electrical noise.

The product does not come with an external supply isolation device.

Fit a suitable electrical supply isolation device, which is easily accessible during use, maintenance, or in the event of an accident or emergency.



The voltage selector switch is not visible while the 620N module is in place. Do not switch the pump on unless you have checked that it is set to suit your power supply by removing the module and inspecting the switch, and then refitting the module. See 20.1 620N module removal and replacement.



Input line fusing: type T 5A H 250V 20mm time-delayed cartridge fuse, located in a fuseholder in the centre of the switchplate at the rear of the pump.

Power interruption: This pump has an auto-restart feature which, when active, will restore the pump to the operating state it was in when power was lost. See 19.12 Auto-restart.

Stop / start power cycles: Do not power up/power down for more than 100 starts per hour, whether manually or by means of the auto-restart facility. We recommend remote control where a high number of starts is required.

Din, Di

11 Start-up check list

Note: See also 27.6, 27.7, 27.8 and 31.5, Tube loading.

- Ensure that proper connections are achieved between the pump tube and suction and discharge piping.
- Ensure proper connection has been made to a suitable power supply.
- Ensure that the recommendations in section 9. Good pump installation practice are followed.

Din, Di

12 Switching the pump on for the first time

Note: This manual uses **bold** type to highlight the active option in menu screens: “**English**” in the first screen represented here. The active option appears on the pump display in **inverse** text.

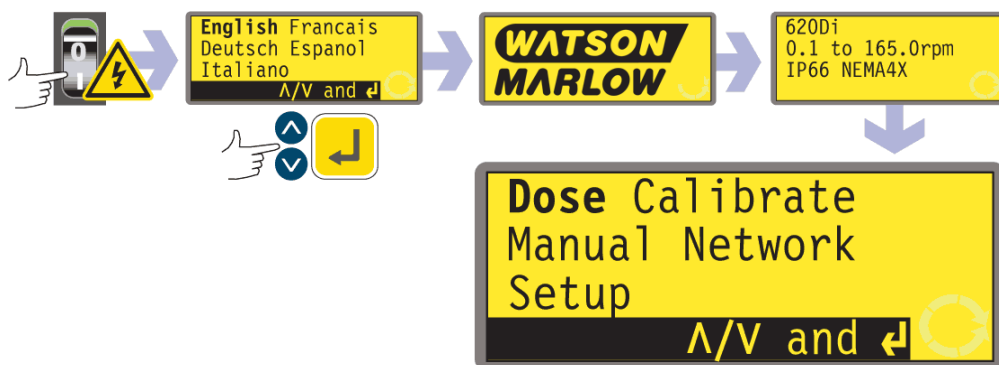

- Switch on the power supply at the rear of the pump. The pump runs a power-on test to confirm proper functioning of the memory and hardware. If a fault is found, an error message is displayed. See 24.1 Error codes.
- The pump displays a language menu. Use the **UP** and **DOWN** keys to select your language. Press the **ENTER** key to confirm your choice.
- **The information which follows assumes that your choice was English.**

- When the language is chosen this menu will not appear again and all menus will appear in the language you chose. (Language can be reset as described later. See 19.19 Language.)
- The pump displays the Flexicon start-up screen for four seconds, followed by the pump model identity screen for four seconds (an example is shown here), and then the main menu.
- The rotation symbol on the display indicates clockwise rotation. The default speed setting is 165rpm, but 265rpm is available (see 19.13 Set maximum allowed speed). Other initial start-up operational parameters are listed in the table below.

620DiN, 620Di: First-time start-up defaults			
Language	Not set	Remote stop	RS (open=run)
Speed	165rpm	Pump number	1
Direction	Clockwise	Baud rate	9600
Pumphead	620L	Stop bits	2
Tube size	9.6mm	Flow control	None
Dosing units	ml	Dose programs	None
Calibration	From head and tube table	Scrolling increment	0.1rpm
Backlight	On	Output 1	Run/Stop *
Keypad lock	Off	Output 2	Direction †
Auto-restart	Off	Output 3	Auto/Man ‡
Pump status	Stopped	Output 4	General alarm
Beeper	On	* Run	= high
Security code	Not set	† Clockwise rotation	= high
Max (prime)	Standard setting	‡ Auto	= high

Note: The settings shown above for Run, Clockwise rotation and Auto are those in force on initial start-up for the functions available on Output 1, Output 2 and Output 3 respectively. For example, a high signal on Output 2 indicates clockwise rotation. These can be exchanged later according to user requirements.

Note: High is equivalent to the common and normally open contacts of the relay on the adapter board being closed.

The pump is now ready to operate according to the defaults listed above.

All operating parameters may be changed by means of key-presses. See 14. Manual operation.

13 Switching the pump on in subsequent power cycles (if not in auto-restart mode)

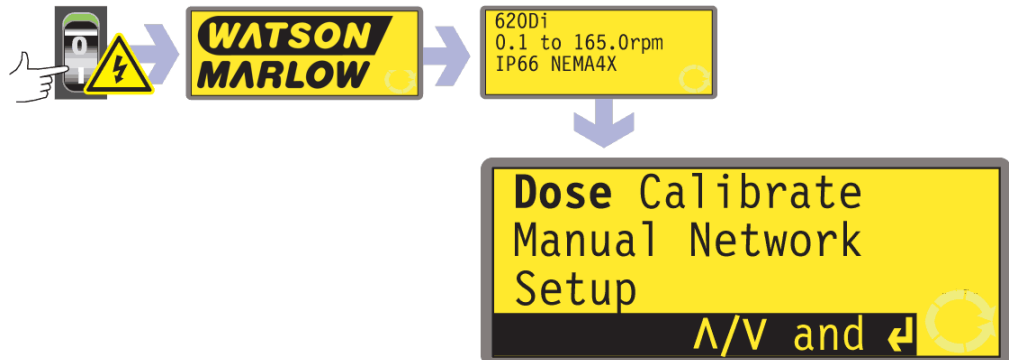

- Switch on the power supply at the rear of the pump. The pump runs a power-on test to confirm proper functioning of the memory and hardware. If a fault is found, an error message is displayed. See 24.1 Error codes.
- The pump displays the Flexicon start-up screen for four seconds followed by the pump model identity screen for four seconds, and then the main menu.
- Start-up defaults are those in place when the pump was switched off last. Check that the pump is set to operate as you require it.

The pump is now ready to operate.

All operating parameters may be changed by means of key-presses. See 14 Manual operation below.

14 Manual operation

14.1 Keypad functions

All settings and functions of the pump in manual mode are set and controlled by means of key-presses. Immediately after the start-up display sequence detailed above, the manual mode main screen will be displayed. The currently selected rotation direction is indicated on the display by a clockwise or counter-clockwise segmented arrow. If an exclamation mark (!) shows, it indicates that Auto-restart is on. If a padlock icon () shows, it indicates that Keypad lock is on.

Note: A number of the controls listed below are shortcuts to commands which are also available through the Main menu. See 15 Main menu.

Note: **SHIFT** gives access to functions which appear on the upper part of numeric keys. To access the **MAX** function, for example, press **SHIFT** once *and release it*. A symbol appears in the bottom left of the display to indicate that the next keypress will be **SHIFT**ed. Press **4 (MAX)**.



A brief single press on each key triggers a beep sound (if enabled - see 14.5 Keypad beep) and causes the pump to function as follows:

- **START:** starts the pump at the speed and in the direction shown on the display. The rotation symbol will become animated to confirm that the pump is operating.

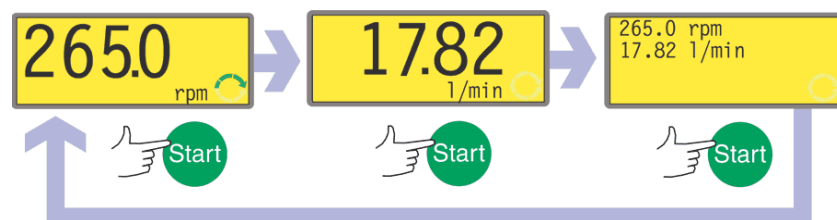

If the pump is running when **START** is pressed, it causes the information shown on the manual mode main screen to cycle from revolutions per minute, to flowrate in a choice of units (via a warning screen if flowrate has not been calibrated and if this is the first cycle since power-up) to rpm and flowrate. An example is shown here. The default can be altered from within the Setup menu (see 19.2 Display).

- **MAX (SHIFT, 4):** while pressed, **MAX (SHIFT, 4)** operates the pump at the maximum allowed speed and in the direction shown on the display. When released, the pump returns to its previous status.
Note: Priming can be achieved by pressing **MAX (SHIFT, 4)** until fluid flows through the pump and reaches the point of discharge, and then releasing **MAX (SHIFT, 4)**.

- **INFO (SHIFT, 9)**: causes the pump to display the volume of fluid it has dispensed since being set to zero or calibrated. **SHIFT, 9 (INFO)** causes the pump to display the volume of fluid it has dispensed since being set to zero or calibrated. The information is displayed only while **SHIFT, 9 (INFO)** is pressed and held. If **STOP** is pressed while the information screen is displayed, the volume dispensed figure is reset to zero.
- **LOAD (SHIFT, 6)**: when the pump is stopped, allows the recall of a dose program from the pump's memory. Has no effect if no program has been stored. Has no effect in Network, Calibration and Setup modes, nor if a numeric entry is called for, a dose parameter is being modified, a program is being saved or if a dose is running.
- **STOP**: if the pump is running, pressing **STOP** stops the pump. The display will continue to show the previous speed and direction. The pump will return to this speed and direction when the **START** key is pressed again.
- **UP**: increases the speed shown on the display in minimum steps of 0.1rpm, or other steps as pre-selected in the Scrolling section of Setup (18.15), (unless the speed displayed is already the maximum allowed speed). If the pump is then started by pressing the **START** key, it will operate at the new speed. If the pump is running when **UP** is pressed, the change takes effect immediately.
Note: If the pump's flow rate has been calibrated (see 18 Calibrate), after a speed change a screen showing the new rpm figure and the new flowrate is displayed for four seconds before returning the user to the previously set manual mode main screen: rpm or flowrate.
- **DOWN**: decreases the speed shown on the display in minimum steps of 0.1rpm, or other steps as pre-selected in the Scrolling section of Setup (18.15). If the pump is then started by pressing the **START** key, it operates at the new speed. The minimum speed possible is 0.1rpm. If the pump is running when **DOWN** is pressed, the change takes effect immediately.
Note: If the pump's flow rate has been calibrated (see 18 Calibrate), after a speed change a screen showing the new rpm figure and the new flowrate is displayed for four seconds before returning the user to the previously set manual mode main screen: rpm or flowrate.
Note: You can reduce the pump speed from 0.1rpm (or any other minimum displayed unit of speed as selected in the Scrolling section of Setup (19.15)) to 0rpm by a further press on the **DOWN** key. The pump is still in the running state and the rotation symbol will continue to move. Press the **UP** key to return the pump to the minimum speed.
Note: If a minimum allowed speed has been set in the Set Min Speed section of the Setup menu, the above note on speed reduction to 0rpm does not apply.
- **DIRECTION (SHIFT, 1)**: toggles the direction of rotation shown on the display. If the pump is then started by pressing the **START** key, it rotates in the new direction. If the pump is running when **DIRECTION** is pressed, the change takes effect immediately.
- **ENTER**: is used to enter/confirm numeric and menu selections. Also cycles the information shown on the manual mode main screen exactly as **START** does, whether the pump is running or not. See **START**, above.
- **MENU (SHIFT, 7)**: causes the main menu to be displayed, from which all aspects of pump setup can be controlled. See 15 Main menu.
- **CLEAR (SHIFT, 5)**: clears numeric entries so that they can be entered again.
- **CAL (SHIFT, 8)**: takes the user to the calibrate sequence.
- **. (decimal point, period) (SHIFT, 0)**: used in numeric expressions as a decimal point. To enter 5.3, press 5, SHIFT, 0, 3. (Some languages use , (comma) to represent a decimal point. This pump uses .)

Keypress combinations cause the pump to function as follows:

Note: A number of the controls listed below are shortcuts to commands which are also available through the Main menu. See 15 *Main menu*.

- **UP** and **1 (DIRECTION)** on power-up: toggles the **keypad beep** on and off.
- **START** on power-up: switches on the **Auto-restart** facility. See 19.12 *Auto-restart*.
- **STOP** on power-up: switches off the **Auto-restart** facility. See 19.12 *Auto-restart*.
- **STOP** and **UP** while the pump is stopped: turns the **display backlight** on.
- **STOP** and **DOWN** while the pump is stopped: turns the **display backlight** off.
- **SHIFT** and **UP**: sets the pump to maximum allowed speed. **Note:** Unlike its action elsewhere, **SHIFT** must be pressed and held. **Note:** The **MAX** key has a similar function, but causes the pump to run at maximum allowed speed only while the key is pressed.
- **SHIFT** and **DOWN**: sets the pump to minimum allowed speed. **Note:** Unlike its action elsewhere, **SHIFT** must be pressed and held.
- **1 (DIRECTION)** and **DOWN**, pressed simultaneously: interrupts the display to show the pump's ROM version for four seconds.
- **START** pressed and held for four seconds: toggles the keypad lock on and off. Only the **START** and **STOP** keys are active when keypad lock is on. The pad-lock icon is displayed.
- **STOP** pressed and held for two seconds: toggles the **keypad lock** on and off. Only the **START** and **STOP** keys are active when keypad lock is on. The pad-lock icon is displayed.

14.2 Speed

To change the running speed:

- Use the **UP** and **DOWN** keys to change the pump's running speed within limits of 0.1 rpm or other minimum allowed speed and the maximum allowed speed. **Note:** You can reduce the pump speed from 0.1 rpm to 0 rpm by a further press on the **DOWN** key. The pump is still in the running state and the rotation symbol will continue to move. Press the **UP** key to return the pump to the minimum speed.

Note: The maximum allowed speed of the drive defaults to 165rpm. It is possible to set this limit at any speed up to 265rpm. See 19.13 *Set maximum allowed speed*, and section 3 *Five-year warranty*.

14.3 Direction

To toggle the pump's rotation sense:

- Press **DIRECTION (SHIFT, 1)** to toggle the pump between clockwise and counter-clockwise rotation. **Note:** Direction control is available subject to access not being limited by security code. See 19.22 *Security code*.

14.4 Keypad lock

The keypad can be locked to prevent changes to pump speed or other settings, and make it possible only to start or stop the pump. The padlock symbol shows on the display.

- While the pump is running, hold down the **START** key for two seconds. The padlock symbol shows and only the **START** and **STOP** keys function.
- The keypad may also be locked while the pump is stopped. Hold down the **STOP** key for two seconds. The padlock symbol shows and only the **START** and **STOP** keys function.
- To unlock the keypad while the pump is running hold down the **START** key for two seconds. The padlock symbol is removed. If the pump is stopped hold down the **STOP** key until the padlock symbol is removed.

Note: Keypad lock is available subject to access not being limited by security code. See 19.22 Security code.

14.5 Keypad beep

The pump keypad can operate silently or indicate a positive key-press with a beep sound.

- To toggle the sound on and off, stop the pump. Turn off the mains power switch at the rear of the pump.
- Depress the **UP** and **1 (DIRECTION)** keys while switching on the mains power switch at the rear of the pump.

See 19.21 Beep.

14.6 Manual operation and remote digital inputs and outputs

The remote run/stop, direction and leak-detected inputs are operational.

The remote status outputs are all fully functional.

The **STOP** key acts as an emergency stop. The run/stop input will not start the pump in manual mode, but once the **START** key has been pressed, the remote run/stop input will stop and start the pump according to its operational state.

(620DiN) If you invert the operation of the remote run/stop switch to operate as open=stop, you must connect the +5V terminal to the i/p terminal on the Run/stop input connector (J4), to be able to start the pump from the keypad. See 20.3 Run/stop input.

(620Di) If you invert the operation of the remote run/stop switch to operate as open=stop, you must connect pin 7 to pin 19, lower D-connector, to be able to start the pump from the keypad. See 21.1 Run/stop input.

If **STOP** is pressed the remote run/stop switch will have no effect.

You cannot invert the polarity of the remote direction signal.

14.7 Backlight

To turn the display backlight on:

- Depress the **STOP** and **UP** keys together.

To turn the display backlight off:

- Depress the **STOP** and **DOWN** keys together.

See 19.16 Backlight.

14.8 Auto-restart

This pump offers an auto-restart feature. When active on power loss, it will restore the pump when power returns to the operating state it was in when power was lost. It does not operate when powering down in the middle of a dose; when the pump is restarted, it will await a press on the **START** key to begin the interrupted dose again. Auto-restart is retained while the pump is switched off. When the pump starts running look for the ! symbol on the display. This ! symbol indicates that the pump is set for auto-restart.



Do not use auto-restart for more than 100 starts per hour. We recommend remote control where a high number of starts is required.

To turn the auto-restart facility on:

- Turn off the mains power switch at the rear of the pump.
- Depress the **START** key while switching on the mains power switch at the rear of the pump.

To turn the auto-restart facility off:

- Turn off the mains power switch at the rear of the pump.
- Depress the **STOP** key while switching on the mains power switch at the rear of the pump.

15 Main menu

15.1 Keypad functions when not in manual mode

- **STOP**: While a dose is running, **STOP** pauses the current dose and stops the pump. **STOP** also functions as a "go back" key, taking the user up one menu level without making a change. During numeric entry, **STOP** clears the current value or restores it to its value on entry to that screen, allowing numeric entry to continue.
- **UP**: The **UP** key is used in menu item selection: it moves a highlight up a menu. In save program mode, it scrolls through 9-0, "space" then Z-A in a circular list.
- **DOWN**: The **DOWN** key is used in menu item selection: it moves a highlight down a menu. In save program mode, it scrolls through A-Z, "space" then 0-9 in a circular list.
- **START**: In Dose mode, the **START** key begins a dose.
- **ENTER**: The **ENTER** key functions in a similar way to the "enter" key of a personal computer: it confirms key-presses made immediately before. In menu item selection, it triggers the action or display selected from a menu using the **UP** and **DOWN** keys.
- **0, 1, 2, 3, 4, 5, 6, 7, 8, 9**: numeric keys are used to enter numbers when a screen asks for numeric input.
- **SHIFT**: Pressing the **SHIFT** key displays an arrow symbol in the lower left corner of the screen, indicating that the next keypress will be in Shift mode. Pressing the **SHIFT** key, then pressing **0, 1, 4, 5, 6, 7, 8** or **9** invokes the action indicated in yellow on those keys, and then cancels Shift mode. If the **SHIFT** key is pressed in error, Shift mode may be cancelled by a second press on the **SHIFT** key.

SHIFT, 0 (.)

enters a decimal point in a numeric expression. The number "10.55", for example, is entered by pressing **1, 0, SHIFT, 0, 5, 5**.

SHIFT, 1 (DIRECTION)

toggles the direction of rotation shown on the display during dispense program setup. When the dispense program is started, the pump rotates in the new direction.

SHIFT, 4 (MAX)

while the pump is in Manual mode or Dose mode at the dose start screen, causes the pump to re-prime itself. If **Always enabled** has been selected (see 19 Setup) it also causes the pump to prime itself in Calibrate mode and in Dose mode while the pump is stopped. It has no effect in Network or Setup modes.

SHIFT, 5 (CLEAR)

during numeric entry, clears the current value or restores it to its value on entry to that screen, allowing numeric entry to continue. Has no effect in other modes.

SHIFT, 6 (LOAD)

when the pump is stopped, allows the recall of a dose program from the pump's memory. Has no effect if no program has been stored. Has no effect in Network, Calibration and Setup modes, nor if a numeric entry is called for, a dose parameter is being modified, a program is being saved or if a dose is running.

SHIFT, 7 (MENU)

displays the Main menu. It operates at any point in the pump's activity except when numeric entry is required or if a dose is running.

SHIFT, 8 (CAL)

when the pump is stopped, begins a full calibration sequence (see 18 Calibrate). Has no effect in Setup and Network modes. While the pump is

dispensing a dose, **SHIFT, 8 (CAL)** allows a change to the dose size (within 25%) called recalibration - which will take effect on the next full dose.

SHIFT, 9 (INFO)

causes the pump to display the volume of fluid it has dispensed since being set to zero or calibrated. In Dose mode, **SHIFT, 9 (INFO)** causes the pump to display the volume of fluid it has dispensed since being set to zero or calibrated, and how many doses per hour it is currently achieving. In both cases, the information is displayed only while **SHIFT, 9 (INFO)** is pressed and held. If **STOP** is pressed while the information screen is displayed, the volume dispensed figure and the doses per hour figure are reset to zero.

SHIFT, UP

has no effect.

SHIFT, DOWN

has no effect.

Note: Confirmation screens are displayed for 4 seconds. While they are displayed, a single press on any key removes them.

15.2 Main menu entry

MENU (SHIFT, 7) displays the main menu and stops the pump if it is running in Manual mode. It operates at any point in the pump's activity except where error screens are displayed, where **UP** and **DOWN** keys are used to enter values, or where a PIN is requested.

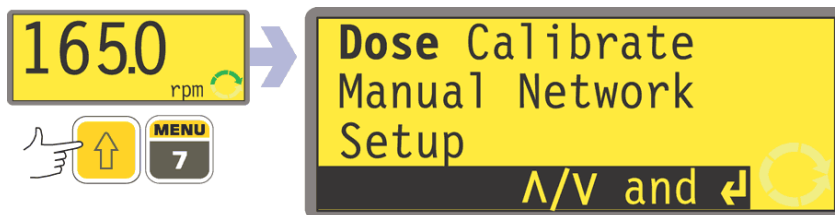

The main menu offers five options: **Dose, Calibrate, Manual, Setup** and **Network**. Use the **UP** and **DOWN** keys to make a choice. Press the **ENTER** key to confirm your decision.

Dose

Except when under manual control, all pump activity is controlled by dispense programs. Selecting **Dose** allows the user to create, amend or select a dispense program, and instruct the pump to carry it out. The pump will stop if **STOP** is pressed, but is otherwise under the control of the dispense program.

Calibrate

Selecting **Calibrate** allows the user to calibrate the pump with default figures for a range of pumpheads and tubes, as well as to refine the flowrate figures with a calibration dose facility.

Manual

Selecting **Manual** allows the user to start, control and stop the pump by means of keypresses.

Network

Selecting **Network** places the pump under external control, using RS232 (620Di) or RS485 (620DiN) network communications.

Setup

Selecting **Setup** allows the user to set the pump's operating parameters under 20 headings: **Dosing, Display, Pump I/D, Baud, Stop bits, Xon/Xoff, Units, Date/time, Max, Outputs, Remote stop, Auto-restart, Set max Speed, Pin out details, Backlight, ROM, Language, Defaults, Beep,** and Security code.

16 PIN-secure process protection

The 620DiN and 620Di feature PIN-secure process protection. This allows the pump to be configured to suit the application, and for the setup to be protected by two levels of PIN code.

Menu option or keypress	With Main code set	With User code set	Code set and keypad locked
Menu (SHIFT, 7)	Available	Available	Not available
Calibrate	Available	Available	Not available
Accept	Available	Available	Not available
Change	Main PIN needed	Main PIN or User PIN needed	Not available
Setup	Main PIN needed	Main PIN needed; User PIN invalid	Not available
Cal (SHIFT, 8)	Available	Available	Not available
Accept	Available	Available	Not available
Change	Main PIN needed	Main PIN or User PIN needed	Not available
Max (SHIFT, 4)	Available	Available	Not available
Dir (SHIFT,1)	Main PIN needed	Main PIN or User PIN needed	Not available
Auto (SHIFT, 9)	Available	Available	Not available
Man (SHIFT, 6)	Available	Available	Not available
Up	Available	Available	Not available
Down	Available	Available	Not available
SHIFT and Up	Available	Available	Not available
SHIFT and Down	Available	Available	Not available
Start	Available	Available	Available
Stop	Available	Available	Available
Enter	Available	Available	Not available
MemoDose	Available	Available	Available
Keypad lock	Main PIN needed	Main PIN or User PIN needed	Main PIN or User PIN needed
Auto-restart	Available	Available	Available

The main code gives access to **Calibrate, Setup, Direction** change and **Keypad lock**.

The secondary (User) code permits **Calibrate, Direction** change and **Keypad lock** but bars **Setup** change.

If either code is used in conjunction with Keypad lock, all keys are disabled except **STOP** and **START**.

To activate and set a security code, see 19.22 Security code.

If the main code is lost or forgotten: The Setup main security code can be bypassed by entering a special key sequence; all codes can then be cancelled and reset. Contact Watson-Marlow Limited or your distributor for details.

17 Dose

Dose mode allows the setup, storage and use of up to 50 different dispense programs. A complete dosing sequence, with all its parameters set, can be initiated by pressing **START** or closing a remote switch.

The dosing parameters are: pumphead type, tube size, calibrated flow, dose size, speed and direction, pause interval, number of doses, start/end ramps and drip adjustment.

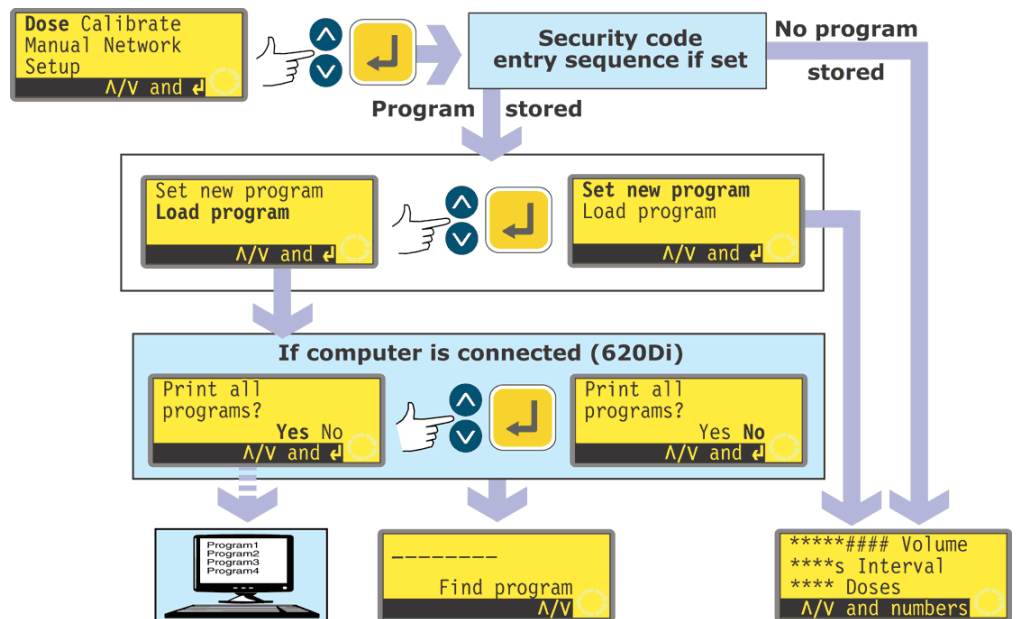

- Use the **UP** and **DOWN** keys to highlight **Dose** in the Main menu. Press **ENTER** to confirm.
- If no dispense program has been saved, the pump displays the first screen of the Set dose program sequence, via the security code entry sequence if one has been set.
- If the pump has stored one or more dose programs, the pump invites the user to set a new program or use an existing one, via the security code entry sequence if one has been set. Use the **UP** and **DOWN** keys to highlight **Set new program** or **Load program**. Press **ENTER** to confirm.
- If **Set new program** is selected, the pump displays the first screen of the Set dose program sequence.
- If **Load program** is selected, the pump displays the Find program screen (see 17.2 Loading a stored dispense program), via an offer to display the available programs on a personal computer if one is connected (620Di only). See 23 Connecting a computer.

Alternatively ...

Press **SHIFT, 6 (LOAD)** to display the Find program screen (if one or more dispense programs have been stored). This shortcut is not available if the pump is in Calibrate mode, numeric entry mode, is modifying a dose parameter, saving a program or if a dose is running.

17.1 Setting a dispense program

Default dispense program settings are:

Pump-head	Tube size	Dose size	Dose interval	Number of doses	Speed	Direction	Start ramp	End ramp	Drip
620L	9.6mm bore	25.0ml	0	10	300	CW	0	0	0

Note: These settings will be restored if the pump is restored to factory defaults.

The Calibration section of this manual (see 18 Calibrate) lists the pumphead and tube size options available, and describes how to tell the pump's software which pumphead and tube are in use. This section of the manual assumes that the user has already chosen his pumphead and tube, and calibrated the pump accordingly.

Setting a new dispense program is the process of changing any or all of the default settings - or of the current settings, if any have previously been changed (apart from pumphead and tube size) - and saving the changed suite of settings as a new dispense program.

The Dispense program parameters menu occupies several screens.

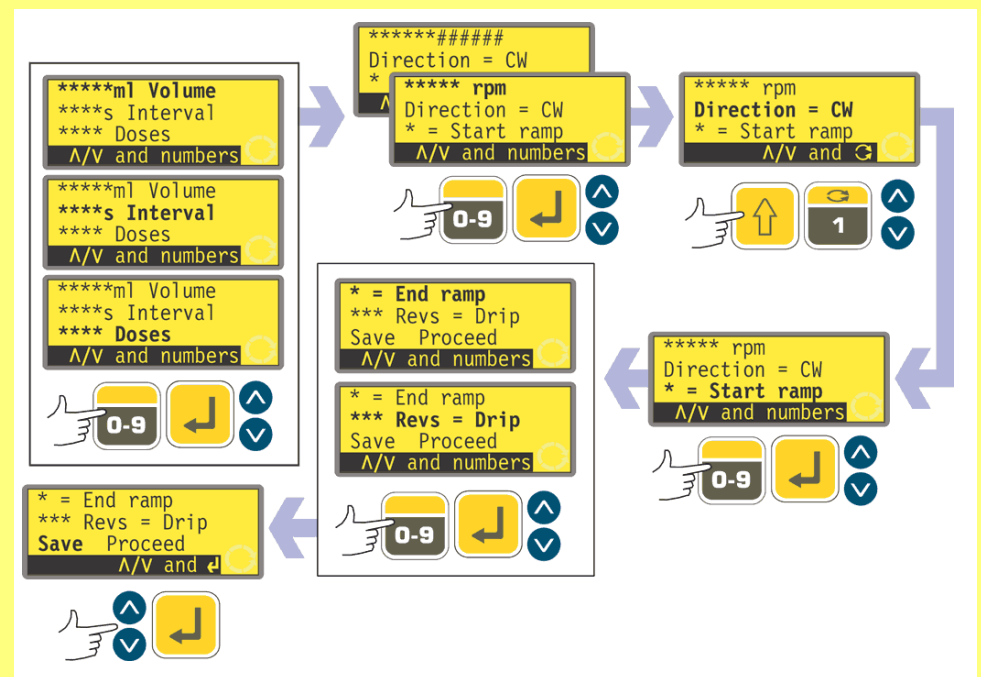

To move from one screen to subsequent screens, repeatedly press **DOWN**. Each item is highlighted in turn until the last item on the screen is highlighted. A further press on the **DOWN** key displays the next screen of the menu, with the first item highlighted.

Follow the reverse procedure using the **UP** key to move to an item on a previous screen of the menu.

Select a parameter using the **UP** or **DOWN** keys. The values shown are the default values or those set for the current dispense program. As each parameter is highlighted, you may accept or change its value.

- If it is correct, do nothing. **UP** and **DOWN** highlight the next parameter.
- If you wish to change it, do so using the keys indicated as available in the bottom line of the screen. When the value is correct, confirm by pressing **ENTER** (if the value is numeric) and use the **UP** or **DOWN** keys to move to the next parameter.
- **At any time during the dose setup sequence the user may press START and the pump may be operated according to the parameters in force. If the next batch requires only the dose size to be changed from the last batch, for example, change it and press START, ignoring the other parameters.**
- The last two items on the last screen of the menu are **Save** and **Proceed**. If the user has made all the required changes, he may save the new settings by highlighting **Save** using the **UP** or **DOWN** keys and pressing **ENTER** to confirm; or he may proceed to run the new program according to the parameters in force by highlighting **Proceed** using the **UP** or **DOWN** keys and pressing **ENTER** to confirm. The amended program will not have been saved and cannot be re-run without re-entering the changes made.



In this programming area, pressing SHIFT, 5 (CLEAR) while setting up dosing parameters returns the value being changed to its original setting, allowing the user to start again.

Dose volume if the units are set to volume

See 19.7 Setup, Flow units.



- Use the **UP** and **DOWN** keys to highlight the **Volume** line of the display (the top line, first screen). The units shown are those chosen during the Setup sequence. See 19.7 Setup.
- If the dose volume displayed is correct, do nothing. **UP** and **DOWN** highlight the next or previous parameter.
- If you wish to change the dose volume, use the numeric keys to enter a new volume. Example figures are shown here. To quickly return to the starting value, press **SHIFT, 5 (CLEAR)**. When the dose volume is correct, press **ENTER** to confirm and use the **UP** and **DOWN** keys to highlight the next parameter. **DOWN** is assumed here.

Dose volume if the units are set to weight

See 19.7 Setup, Flow units.

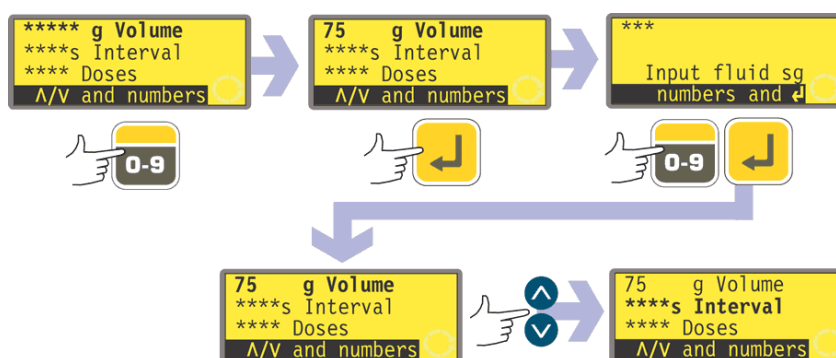

- Use the **UP** and **DOWN** keys to highlight the weight line of the display (the top line, first screen - still called **Volume**). The units shown are those chosen during the Setup sequence. See 19.7 Setup.
- If the dose weight displayed is correct, do nothing. **UP** and **DOWN** highlight the next or previous parameter.
- If you wish to change the dose weight, use the numeric keys to enter a new weight. Example figures are shown here. To quickly return to the starting value, press **SHIFT, 5 (CLEAR)**. When the dose weight is correct, press **ENTER** to confirm.
- The pump invites you to enter the specific gravity of the duty fluid. Use the numeric keys to do so. Press **ENTER** to confirm. The pump redisplay the first menu screen. Use the **UP** and **DOWN** keys to highlight the next parameter. **DOWN** is assumed here.



Note: The dose size must use more than 0.5 revolutions of the pumphead. To obtain best accuracy the dose size should use more than five revolutions. Where the dose size uses less than five revolutions, the pump may warn that a smaller tube size is required. If you do not change the tube size, the pump may proceed with your selected dose size but accuracy may be reduced. If the dose is smaller than the 0.5 revolution minimum, the pump displays a warning and does not allow you to proceed. Both warning screens are displayed for four seconds, unless cancelled by any keypress. If you wish to proceed with the dose size, you must perform a new pump calibration using a smaller tube size. (See 18 Calibrate).

Dose interval

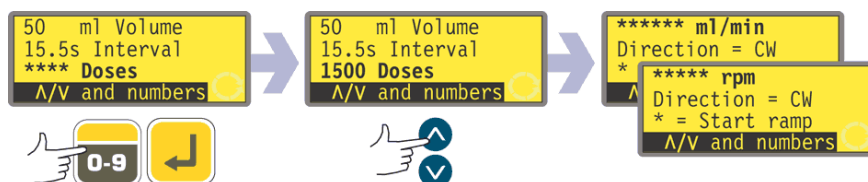

- Use the **UP** and **DOWN** keys to highlight the dose **Interval** line of the display (the second line, first screen). The display shows the previously set time interval between doses in seconds.
- If the interval displayed is correct, do nothing. **UP** and **DOWN** highlight the next or previous parameter.
- If you wish to change the interval between doses, use the numeric keys to

enter the required interval, from 0 seconds to 999 seconds. Example figures are shown here. To quickly return to the starting value, press **SHIFT, 5 (CLEAR)**. Press **ENTER** to confirm. If you wish to change other parameters, use the **UP** and **DOWN** keys to highlight each as required. **DOWN** is assumed here.

Note:

Interval = 0 : Discrete doses each triggered by pressing START, in batch or not

Interval > 0 : Completes batch automatically if doses > 1. Press START to begin

Number of doses

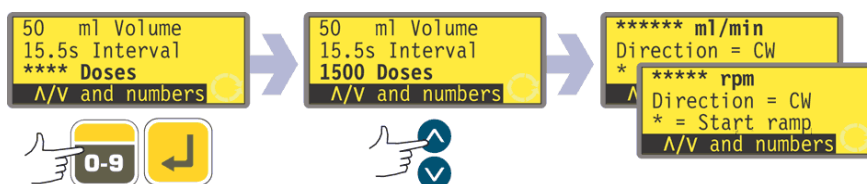

- Use the **UP** and **DOWN** keys to highlight the **Doses** line of the display (the third line, first screen). The display shows the previously set number of doses.
- If the number displayed is correct, do nothing. **UP** and **DOWN** highlight the next or previous parameter.
- If you wish to change the number of doses, use the numeric keys to enter the required number, from 1 to 9999. Example figures are shown here. To quickly return to the starting value, press **SHIFT, 5 (CLEAR)**. Press **ENTER** to confirm. If zero is entered, a warning screen is displayed briefly and the opportunity to choose a dose number is repeated. If you wish to change other parameters, use the **UP** and **DOWN** keys to highlight each as required. **DOWN** is assumed here.

Note:

Doses = 1 : No batch. The display counts up. Press START for each dose

Doses > 1 : Batch. The display counts down. Press START to begin batch

Pump speed or flowrate

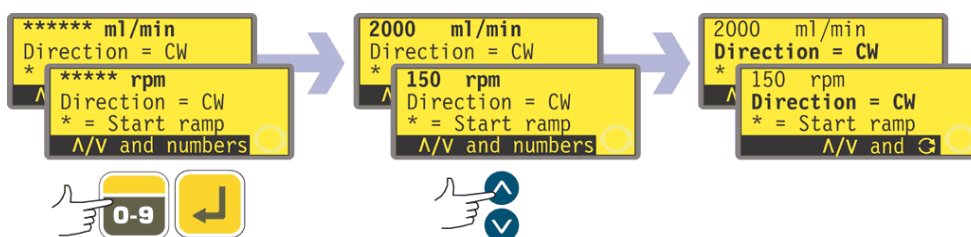

- Use the **UP** and **DOWN** keys to highlight the speed line of the display (the first line, second screen). The display shows the previously set pump speed OR the previously set flowrate. Flowrate is displayed if you chose **Flowrate** as the preferred units for dosing flow as part of the Setup sequence. See 19 Setup.
- If the speed or flowrate displayed is correct, do nothing. **UP** and **DOWN** highlight the next or previous parameter.
- If you wish to change the speed or flowrate, use the numeric keys to enter the required speed or flowrate. If the value selected for speed or flowrate is outside the band allowed by the information entered when the pump was calibrated, a warning is shown and you are invited to enter a new value. Alternatively, you may need to recalibrate or choose a new tube size. Example figures are shown here. To quickly return to the starting value, press **SHIFT, 5 (CLEAR)**. Press **ENTER** to confirm. If you wish to change other parameters, use the **UP** and

DOWN keys to highlight each as required. **DOWN** is assumed here.

Pump direction

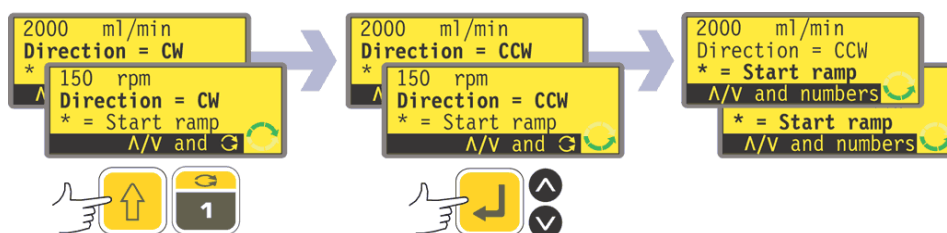

- Use the **UP** and **DOWN** keys to highlight the **Direction** line of the display (the second line, second screen). The display shows the previously set direction of rotation.
- If the direction displayed is correct, do nothing. **UP** and **DOWN** highlight the next or previous parameter.
- If you wish to change the direction, press **SHIFT, 1 (DIRECTION)** to toggle the displayed direction. An example is shown here.
Note: The direction icon at the lower right corner of the display screen also changes.
- If you wish to change other parameters, use the **UP** and **DOWN** keys to highlight each as required. **DOWN** is assumed here.

Alternatively ...

Press **SHIFT, 1 (DIRECTION)** at any point in the menu sequence.

Start ramp

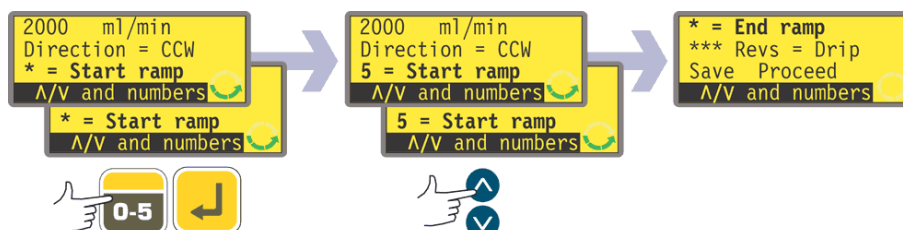

- Use the **UP** and **DOWN** keys to highlight the **Start ramp** line of the display (the third line, second screen). The display shows the start ramp setting of the last dosing session. When set to 0 the pump starts abruptly at full speed. When set to 5 the pump accelerates softly to full speed.
- If the setting displayed is correct, do nothing. **UP** and **DOWN** highlight the next or previous parameter.
- If you wish to change the setting, use the numeric keys to enter the desired setting: **0, 1, 2, 3, 4** or **5**. An example is shown here. To quickly return to the starting value, press **SHIFT, 5 (CLEAR)**. If a number greater than 5 is entered, 5 is displayed and entered. Press **ENTER** to confirm. If you wish to change other parameters, use the **UP** and **DOWN** keys to highlight each as required. **DOWN** is assumed here.

End ramp

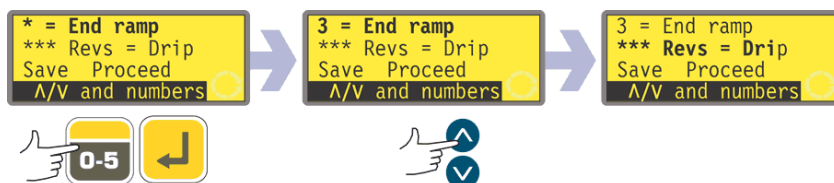

- Use the **UP** and **DOWN** keys to highlight the **End ramp** line of the display (the first line, third screen). The display shows the end ramp setting of the last dosing session. When set to '0' the pump stops abruptly. When set to '5' the pump decelerates softly to a stop.
- If the setting displayed is correct, do nothing. **UP** and **DOWN** highlight the next or previous parameter.
- If you wish to change the setting, use the numeric keys to enter the desired setting: **0, 1, 2, 3, 4** or **5**. An example is shown here. To quickly return to the starting value, press **SHIFT, 5 (CLEAR)**. If a number greater than 5 is entered, 5 is displayed and entered. Press **ENTER** to confirm. If you wish to change other parameters, use the **UP** and **DOWN** keys to highlight each as required. **DOWN** is assumed here.

Drip

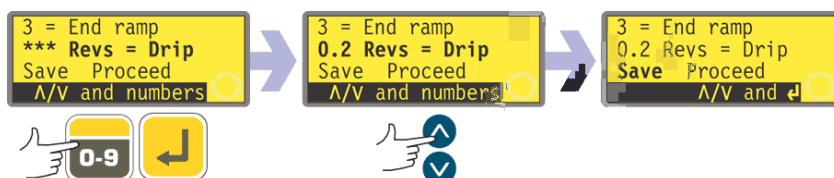

The pump can be set to reverse briefly at the end of each dose to prevent drips.

- Use the **UP** and **DOWN** keys to highlight the **Drip** line of the display (the second line, third screen). The display shows the drip setting of the last dosing session: from 0 to 1.0 (zero to one revolution) at one-tenth of a revolution intervals.
- If the setting displayed is correct, do nothing. **UP** and **DOWN** highlight the next or previous parameter.
- If you wish to change the setting, use the numeric keys to enter the desired setting: zero revolutions to 1 revolution at 0.1 revolution intervals. An example is shown here. To quickly return to the starting value, press **SHIFT, 5 (CLEAR)**. If a number greater than 1.0 is entered, 1.0 is displayed and entered. Press **ENTER** to confirm. If you wish to change other parameters, use the **UP** and **DOWN** keys to highlight each as required. **DOWN** is assumed here.

Note: The time taken by drip reversal is added to any dose interval time which may have been set.

Save and Proceed

The pump can operate immediately according to the parameters just entered; or you can save those settings by name as a dispense program for use now or later.

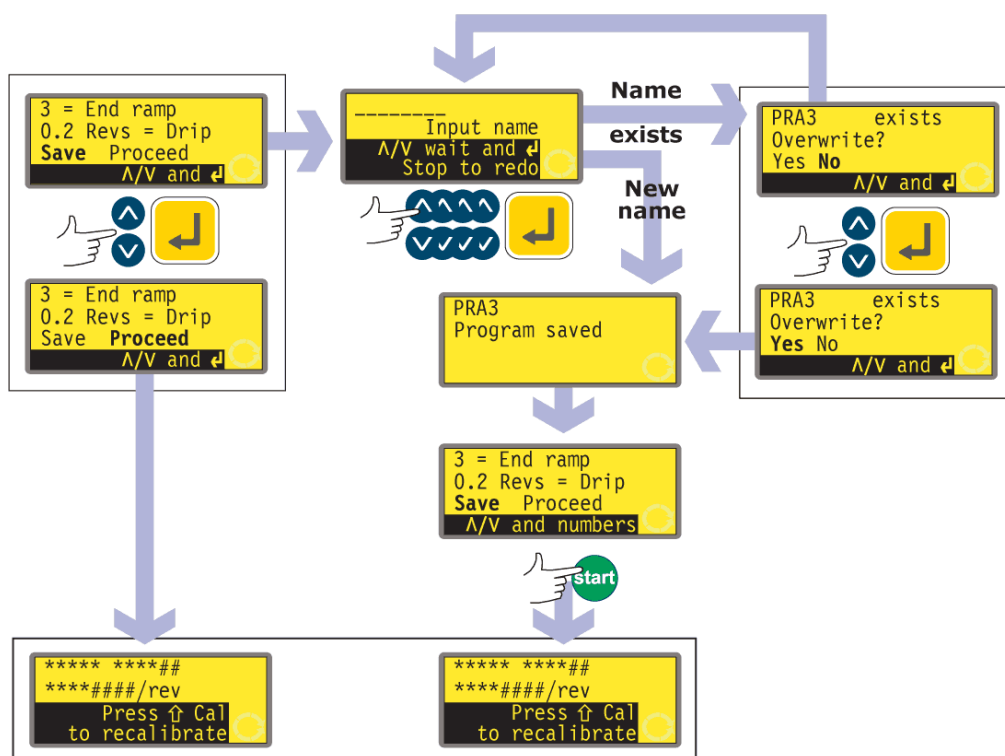

* **Note:** It is not necessary to cycle through all the dispense program settings before saving the new program or starting to dispense. You can jump straight to Save or Proceed at any point in the dispense program setting sequence; or you can press START at any point in the dispense program setting sequence.

- Use the **UP** and **DOWN** keys to highlight **Proceed** or **Save** (the third line, third screen).
- If you want the pump to operate without saving the parameters you have just set, press **START** or highlight **Proceed** and press **ENTER** to confirm. The pump briefly displays its pumphead, tube bore and flowrate settings. Even if you do not save the settings (and as long as you use no other saved settings), these values will be available the next time you use Dose mode.
- If you want to save the parameters you have just set, highlight **Save**. Press **ENTER** to confirm. The pump invites you to enter a name of up to eight characters for the new dispense program. An example name and settings are shown here.
- The name may include the letters A-Z, 'space' and the figures 0-9, entered one character at a time. Use the **UP** and **DOWN** keys to scroll the available characters. When the name entry screen first appears, a cursor highlights the space for the first character. Pressing **UP** causes the letter A to appear; pressing **UP** again within one second causes the letter B to appear... Pressing **DOWN** causes the figure 9 to appear; pressing **DOWN** again within one second causes the figure 8 to appear...
- After a delay of 1 second, the current character is accepted and the cursor moves on to the second space. Repeat to select the second character. If a 'space' is required at any point in the name, use the **UP** and **DOWN** keys to scroll to it: 'space' is located between 9 and A.
- At any time in entering the program name you may press **STOP** to delete the last character entered and replace it with another character. If **STOP** is pressed

- repeatedly, any number of characters or the entire name may be removed.
- When the program name is complete - any number of characters up to eight - press **ENTER** to save the program with that name.
 - If the name is accepted, the pump briefly displays a confirmation screen with the message **Program saved**.
 - If the name duplicates the name of a dispense program previously saved, the pump asks if the user wishes to overwrite the existing program with the new program. Use the **UP** and **DOWN** keys to highlight **Yes** or **No** and press **ENTER** to confirm. If **No** was selected, the pump invites the user to enter a new name; if **Yes** was selected, the pump briefly displays a confirmation screen with the message **Program saved**.
 - The pump redisplay the third screen of the dispense program setting sequence. If the user wishes to run the new program, he may select **Proceed** as above or press **START**. The pump briefly displays its pumphead, tube bore and flowrate settings.

17.2 Loading a stored dispense program

If the user selected **Load program** from the Dose options displayed after selecting **Dose** on the Main menu screen, the Find program screen is displayed.

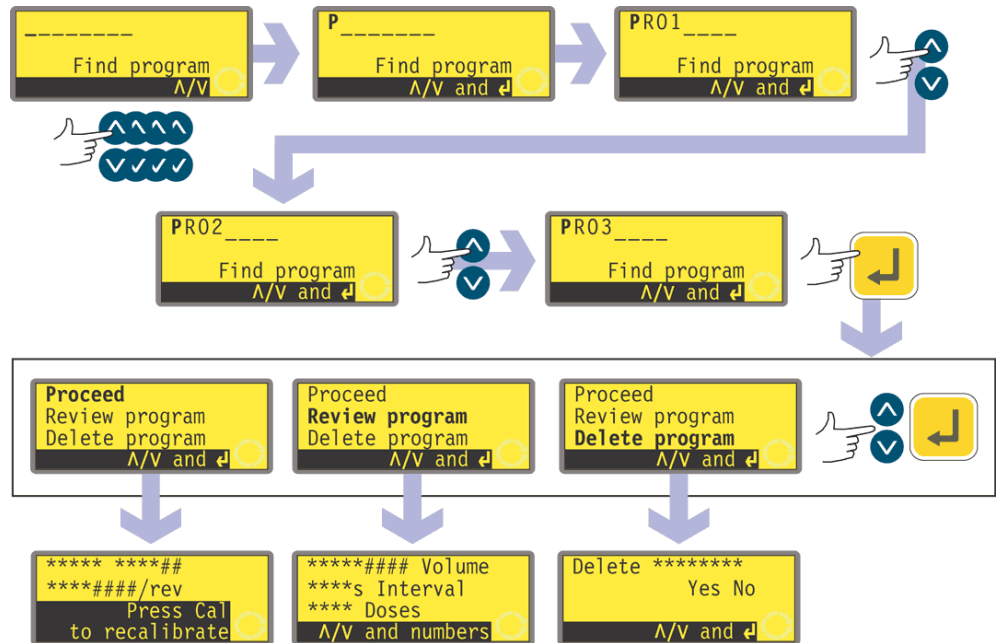

- Use the **UP** and **DOWN** keys to highlight the first character of the dosing program you wish to load. Pressing **UP** causes the letter A to appear; pressing **UP** again within one second causes the letter B to appear... Pressing **DOWN** causes the figure 9 to appear; pressing **DOWN** again within one second causes the figure 8 to appear...
 - After a delay of 1 second, the pump displays the full name of its first stored program beginning with the displayed character.
 - Use the **UP** and **DOWN** keys to display the full names of all stored programs. Examples are shown here.
 - When the required program name is displayed, press **ENTER** to confirm.
 - The pump offers three choices: **Proceed**, **Review program** and **Delete program**. Use the **UP** and **DOWN** keys to highlight an option and press **ENTER** to confirm.
 - If **Proceed** was chosen, the pump runs the selected program. See 17.3 Starting a dispense program.
 - If **Review program** was chosen, the pump displays the first screen of the Dispense program parameters menu. See 17.1 Setting a dispense program.
 - If **Delete program** was chosen, the pump asks for confirmation. Use the **UP** and **DOWN** keys to highlight **Yes** to delete the program; highlight **No** to retain the program and return to the previous screen.
- Note:** If the security code is set, the user must correctly enter the security code before the pump will delete the program. See 19.22 Security code entry.

17.3 Starting a dispense program

DiN

After a dispense program has been set or loaded, it may be started.

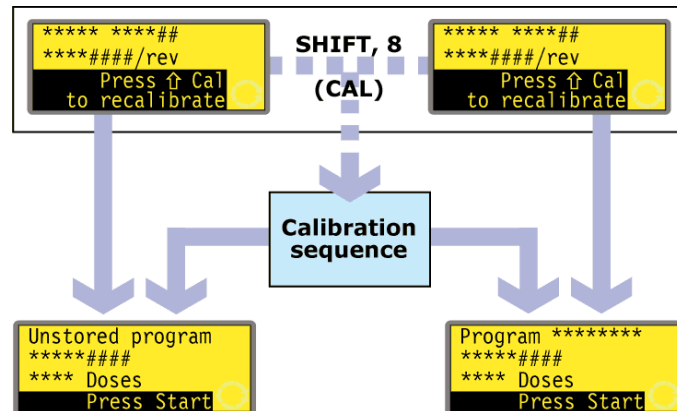

- If **SHIFT, 8 (CAL)** is pressed, the pump allows the user to run the calibration sequence. See 18 Calibrate.
- When calibration is complete or if it was not selected, the pump summarises the program it is ready to run and invites the user to press **START** or apply a remote signal (see 20.5 Dose input) to start it.

Di

When a dispense program has been set or loaded, it may be started. An invitation to recalibrate the pump is displayed for 3 seconds, before a summary of the program appears.

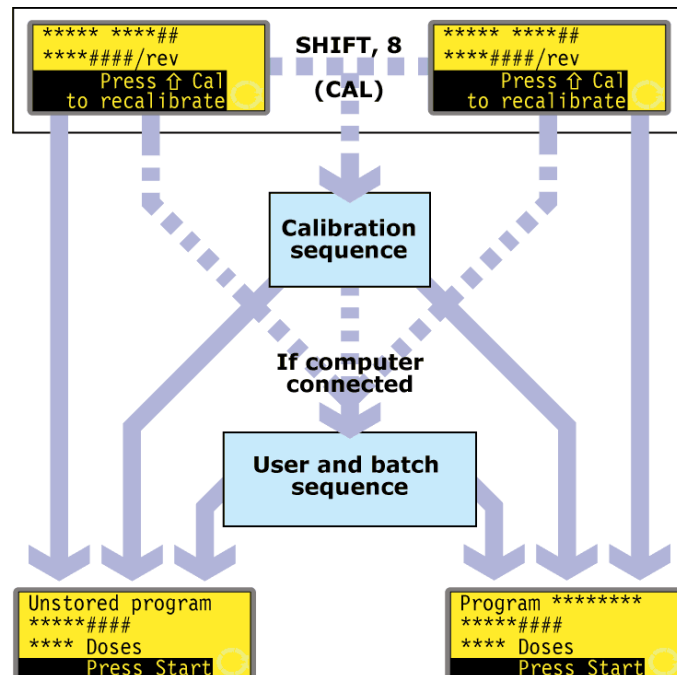

- If **SHIFT, 8 (CAL)** is pressed, the pump allows the user to run the calibration sequence. See 18 Calibrate.
- When calibration is complete or if it was not selected, the pump checks whether a computer is connected to the pump. If so, the pump allows the user to enter information about the pump operator and the dispense batch. See User and batch sequence.
- When user and batch information has been entered, or if no computer is connected to the pump, the pump summarises the program it is ready to run and

invites the user to press **START** or apply a remote signal (see 20.5 Dose input) to start it.

17.4 User and batch sequence

If a computer is connected to the pump, the pump records two pieces of information about the current batch.

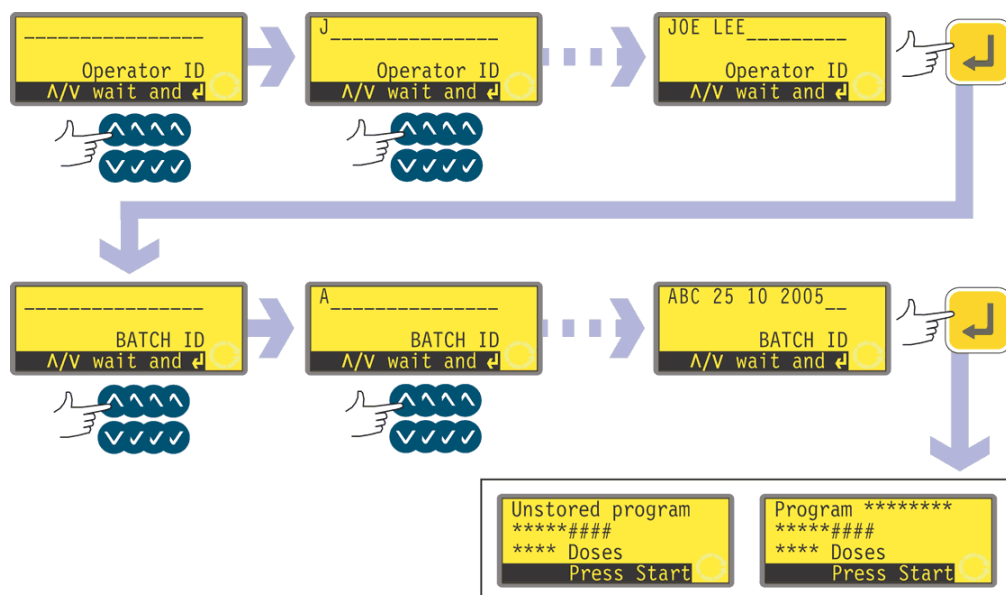

- The pump asks for the name of the operator. Up to 16 characters may be entered.
- Use the **UP** and **DOWN** keys to highlight the first character of the operator's name. Pressing **UP** causes the letter A to appear; pressing **UP** again within one second causes the letter B to appear... Pressing **DOWN** causes the figure 9 to appear; pressing **DOWN** again within one second causes the figure 8 to appear...
- After a delay of 1 second, the current character is accepted and the cursor moves on to the second space. Repeat to select the second character. If a 'space' is required at any point in the name, use the **UP** and **DOWN** keys to scroll to it: 'space' is located between 9 and A.
- When the name is complete, press **ENTER** to confirm. The operator's name is saved. The information entered will be output when the batch is run.
- The pump asks for the name of the batch. Up to 16 characters may be entered.
- Use the **UP** and **DOWN** keys to highlight the first character of the batch name. Pressing **UP** causes the letter A to appear; pressing **UP** again within one second causes the letter B to appear... Pressing **DOWN** causes the figure 9 to appear; pressing **DOWN** again within one second causes the figure 8 to appear...
- After a delay of 1 second, the current character is accepted and the cursor moves on to the second space. Repeat to select the second character. If a 'space' is required at any point in the name, use the **UP** and **DOWN** keys to scroll to it: 'space' is located between 9 and A.
- When the name is complete, press **ENTER** to confirm. The batch name is saved. The information entered will be output when the batch is run.
- The pump summarises the program it is ready to run and invites the user to press **START** to run it.

17.5 While a dispense program is running

A dispense program may call for the pump to dispense:

- a batch containing a known number of single doses, each dosed on demand by a trigger such as a press on **START** or a footswitch, or a plc signal (note that at the end of such a batch the options available are to return to the main menu or to repeat the batch by pressing **START**);
- a batch of a known number of doses with a pre-set time interval between doses, started by a trigger as above;
- an unknown number of doses to be dosed singly on demand by a trigger as above.

The first two options are governed by the Dose interval setting in the dispense program. See 17.1 Setting a dispense program. If the interval is set to zero, the pump dispenses doses singly. If the interval is set to any other figure, the batch will be dispensed.

The third option is governed by the Number of doses setting in the dispense program. See 17.1 Setting a dispense program.

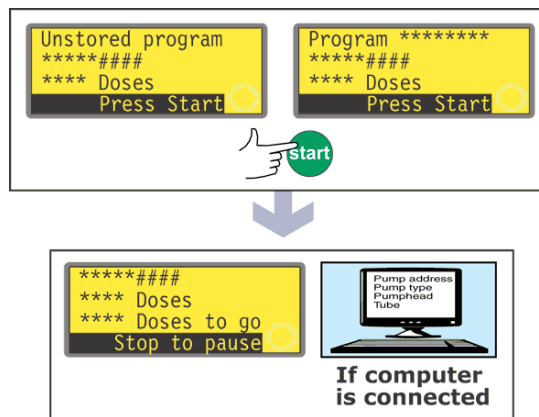

- Press **START**.
- The pump starts dispensing the first dose of the batch, and displays its progress: dose size; how many doses in the batch are still to be dispensed; how many doses in the batch have been dispensed.
- If a computer is connected to the pump (620Di only), all the current program parameters are output, plus the current date and time. An example is shown here:

```
Pump address 16
Pump type 620Di
Pumphead 620L
Tube 6.4 mm
Program name PROG1
Flow calibration 6.780 ml/rev
Dose size 123.4 ml
Interval 10 s
Number of doses 9999
Speed 100.5 rpm
Direction CCW
Start ramp 0
End ramp 1
Drip 1

Operator ID Joe Lee
Batch ID ABC 25 10 2005
Date 25.10.05
Time 16:42:00
Program started
```

A batch of single doses

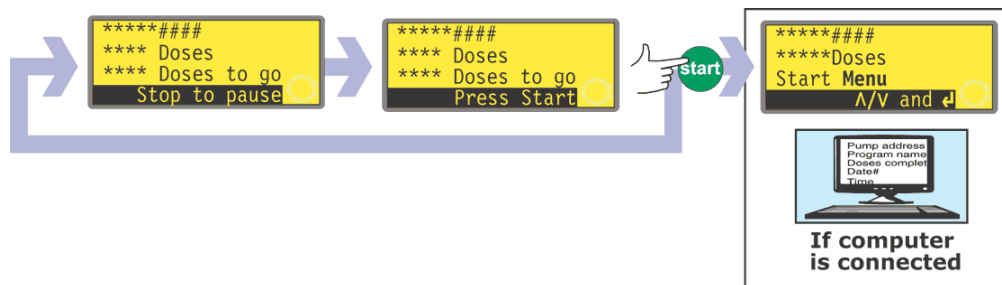

- If the batch was set to be dispensed with an interval between doses of zero seconds, the pump stops after dispensing the first dose of the batch and waits for a further press on **START**.
- When **START** is pressed it starts dispensing the next dose of the batch, and displays its progress: dose size; how many doses in the batch have been dispensed; how many doses in the batch are still to be dispensed.
- This cycle is repeated until the batch is complete. The pump summarises the batch just completed.
- Use the **UP** and **DOWN** keys to select **Menu** to return to the Main menu and press **ENTER** to confirm.
- Use the **UP** and **DOWN** keys to select Start to run the batch again, and press **ENTER** to confirm.

Alternatively...

Press **START** to run the batch again.

- If a computer is connected to the pump (620Di only), a log message is output. An example is shown here:

```
Pump address 16
Program name PROG1
Doses completed 9999
Date 25.10.05
Time 16:42:00
Batch completed
```

The batch can be paused or stopped at any time.

- Press **STOP** or apply a remote pause-dose signal, while the batch is being dispensed to pause or stop the batch. See 17.6 To stop or pause a dispense program.

A batch of timed doses

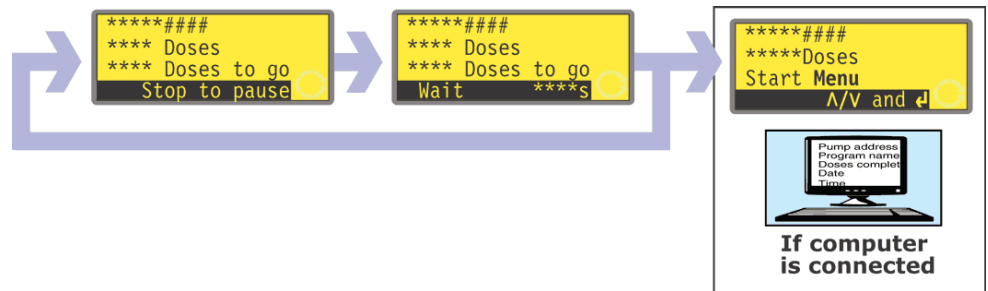

- If the batch was set to be dispensed with an interval between doses greater than zero seconds, the pump stops after dispensing the first dose of the batch and waits for the interval to pass.
- When the interval has passed it starts dispensing the next dose of the batch, and displays its progress: dose size; how many doses in the batch have been dispensed; how many doses in the batch are still to be dispensed.
- This cycle is repeated until the batch is complete. The pump summarises the batch just completed. Use the **UP** and **DOWN** keys to select **Menu** to return to the Main menu and press **ENTER** to confirm. Use the **UP** and **DOWN** keys to select **Start** to run the batch again, and press **ENTER** to confirm. Alternatively... Press **START** to run the batch again.
- If a computer is connected to the pump (620Di only), a log message is output. An example is shown here:

```
Pump address 16
Program name PROG1
Doses completed 9999
Date 25.10.05
Time 16:42:00
Batch completed
```

The batch can be paused or stopped at any time.

- Press **STOP** or apply a remote pause-dose signal, while the batch is being dispensed to pause or stop the batch. See 17.6 To stop or pause a dispense program.

An unknown number of single doses



- If the batch was set to contain 1 dose, the pump starts dispensing the dose, and displays its progress: dose size; and how many doses have been dispensed. It stops after dispensing that dose and waits for a further press on **START**.
- Press **START** to run the batch again.

The cycle can be paused or stopped at any time.

- To pause a dose, press **STOP** or apply a remote pause-dose signal while a dose

is being dispensed. See 17.6 To stop or pause a dispense program.

- To stop the cycle, press **STOP**, or apply a remote pause-dose signal, after a dose has been dispensed. See 17.6 To stop or pause a dispense program.

17.6 To stop or pause a dispense program

A batch can be stopped or paused by pressing **STOP**, or applying a remote pause-dose signal, while the batch is being dispensed. See 19.11 Remote stop.

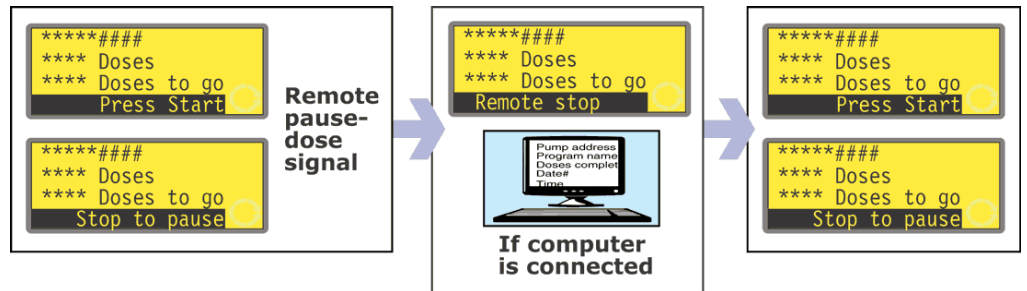

- If the batch was paused by applying a remote pause-dose signal, the pump stops and displays its progress; when the remote pause-dose signal is no longer applied, the pump continues from where it left off, completing any interrupted dose.

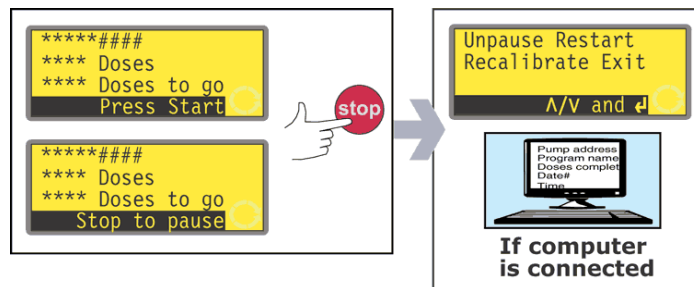

- If the batch was paused by pressing **STOP**, the pump stops and offers four choices: **Unpause, Restart, Recalibrate** and **Exit**.
- In either case (pause or stop), if a computer is connected to the pump (620Di only), a status message is output. An example is shown here:

```
Pump address 16
Program name PROG1
Doses completed 520
Doses to go 9479
Date 25.10.05
Time 16:52:00
Batch paused
```

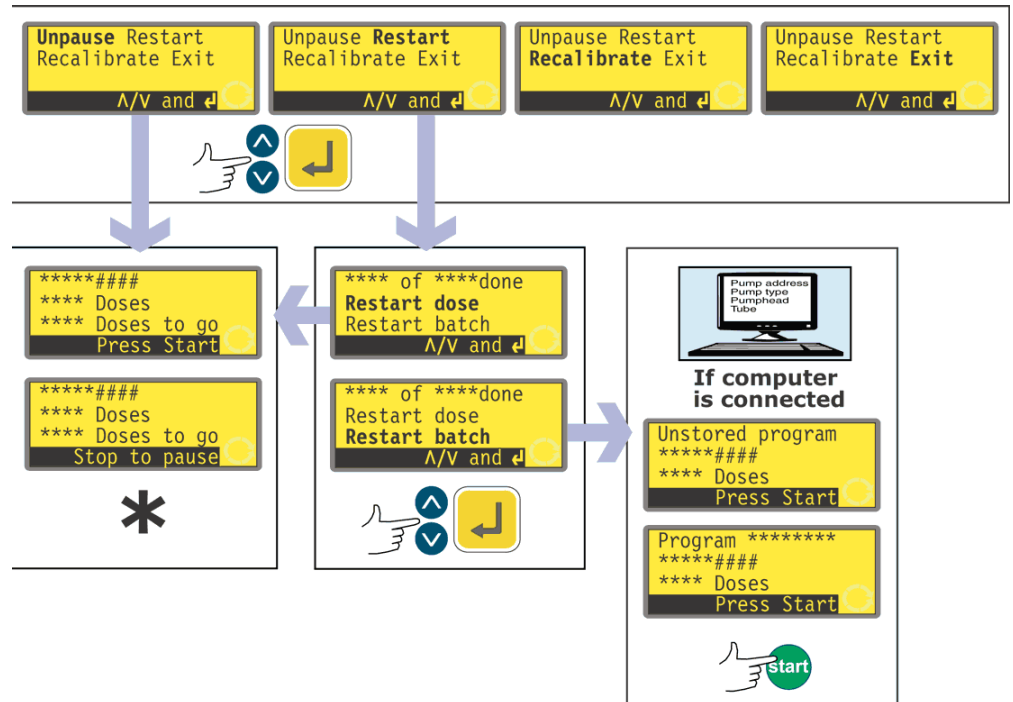

* **Note:** If dispensing is resumed after a remote pause-dose signal or by selecting **Unpause**, any interrupted dose is continued. If dispensing is resumed by selecting **Restart**, any interrupted dose is aborted and repeated from its start.

- Use the **UP** and **DOWN** keys to make a selection and press ENTER to confirm.
- If **Unpause** is selected, dispensing is resumed where it left off. Any interrupted dose is completed.
- If **Restart** is selected, the pump offers to restart any interrupted dose or to restart the interrupted batch. Use the **UP** and **DOWN** keys to highlight **Restart dose** or **Restart batch** and press **ENTER** to confirm.
 - If **Restart dose** is selected, dispensing is resumed where it left off. Any interrupted dose is aborted and repeated from its start.
 - If **Restart batch** is selected, the interrupted batch is aborted and the pump waits for **START** to be pressed to begin the batch again.
 - If a computer is connected to the pump (620Di only), a status message is output. An example is shown here:

```
Pump address 16
Program name PROG1
Doses completed 521
Date 25.10.05
Time 16:59:00
Batch aborted
```

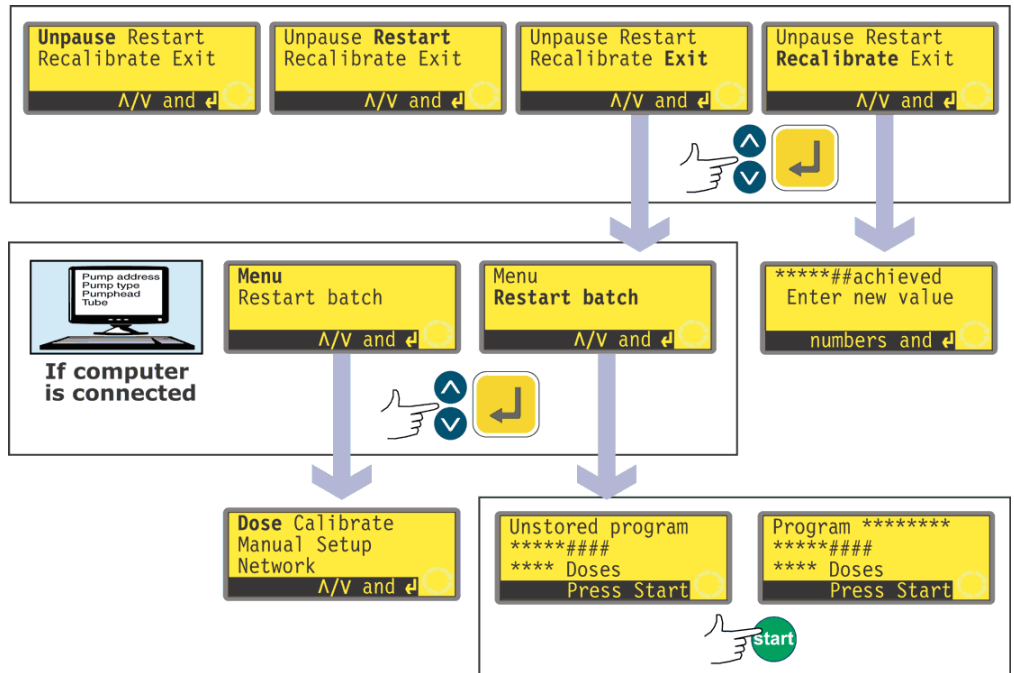

- Use the **UP** and **DOWN** keys to make a selection and press **ENTER** to confirm.
- If **Exit** is selected, the pump offers to restart the interrupted batch or to display the Main menu. In either case the previous batch is aborted. Use the **UP** and **DOWN** keys to highlight **Menu** or **Restart batch** and press **ENTER** to confirm.
 - If a computer or printer is connected to the pump (620Di only), a status message is output. An example is shown here:

```
Pump address 16
Program name PROG1
Doses completed 521
Date 25.10.05
Time 16:59:00
Batch aborted
```

- If **Menu** is selected, the pump displays the Main menu.
- If **Restart batch** is selected, the pump waits for **START** to be pressed to begin the batch again.
- If **Recalibrate** is selected, the pump may be recalibrated. See 18 Calibrate.

Note: Recalibration can also be invoked during dosing. Press **SHIFT, 8 (CAL)** while a dose is being dispensed. The dose will continue to run while the recalibration is performed. The current dose will not be affected; the new calibration will take effect from the next dose. If **SHIFT, 8 (CAL)** is pressed when dosing is stopped, full calibration (as against recalibration) may be performed. See 18 Calibrate.

18 Calibrate

Calibrate and Recalibrate are different processes. **Calibrate** allows the user to set up the pump before use to correctly display flowrate in the units per revolution chosen during the Setup sequence. (See 19 Setup.) **Recalibrate** allows the user to adjust the pump's flowrate while it is in use; it can even be initiated while a dispense batch is running (by pressing **SHIFT, 8 (CAL)**).

Pumphead and tube sizes available

Pumphead	Tube sizes (mm)	
620R	6.4, 9.6, 12.7, 15.9	Note: 620R, 620RE and 620RE4 pumpheads are driven by a dedicated 620 drive; 620L and 620LG pumpheads are driven by a dedicated 620 drive. Pumpheads are not interchangeable between drive types. 625L pumpheads are not suitable for use with either type of 620 drive.
620RE, 620RE4	12.0 17.0 (bore)	
620L, 620LG	8.0, 12.0, 16.0	

Calibrate

To dispense the correct amount of fluid the pump must know which pumphead is fitted and the tube size in the pumphead. The pump is pre-programmed with default flow rate figures for a range of pumpheads and tubes. For the most accurate calibration, you may measure the flow from the pump and enter this value instead of the default.

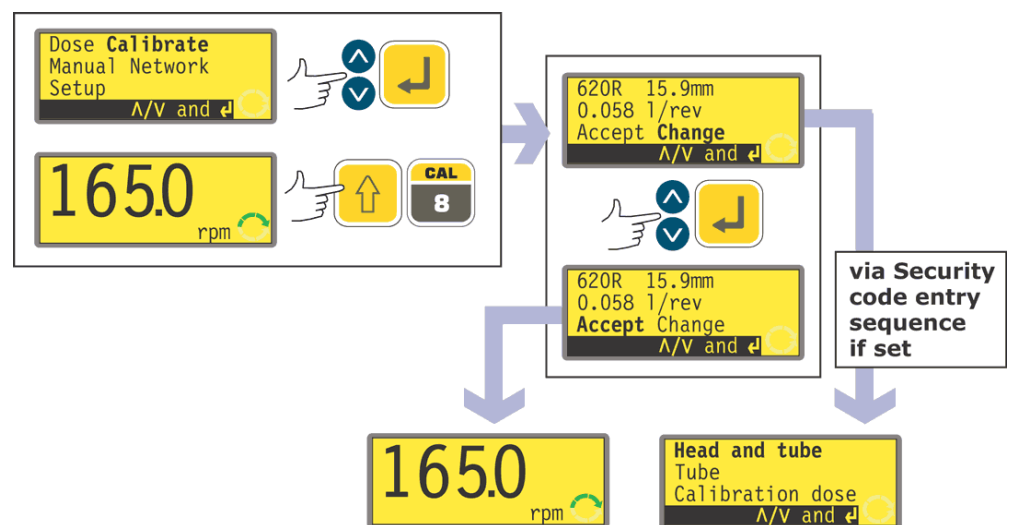

- Use the **UP** and **DOWN** keys to highlight **Calibrate** in the main menu. Press **ENTER** to confirm.
- The pump displays its current settings: pumphead, tube size and flowrate; the default for each standard pumphead is the largest tube the pumphead can take. Example information is shown here.
- Use the **UP** and **DOWN** keys to highlight **Accept** or **Change**. Press **ENTER** to confirm.
- If **Accept** is selected, the default or previously set flowrate data for that pumphead and tube size are used in flowrate calculations. The pump displays the main running screen.
- If **Change** is selected with a security code in place, the pump starts its security code entry sequence. See 19.22 Security code entry. When the correct code is

entered, the pump offers three options: **Head and tube**; **Tube**; and **Calibration dose**. If **Change** is selected with no security code in place, the three options are displayed immediately.

- Use the **UP** and **DOWN** keys to make a selection. Press **ENTER** to confirm.

Head and tube

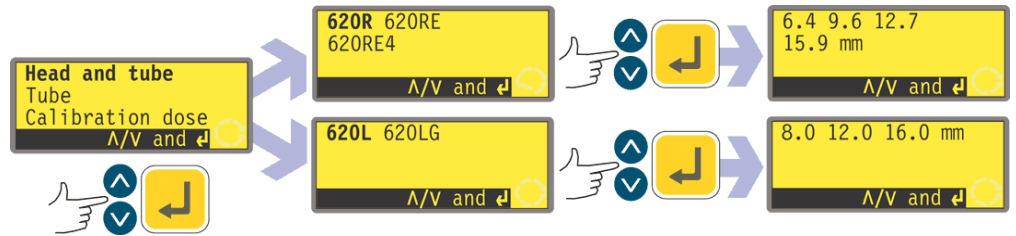

- If **Head and tube** is selected, the pump displays a list of standard pumpheads that can be fitted to the pump.
- Use the **UP** and **DOWN** keys to make a selection. Press **ENTER** to confirm. Examples are shown here.
- The pump displays tube sizes, as below.

Tube

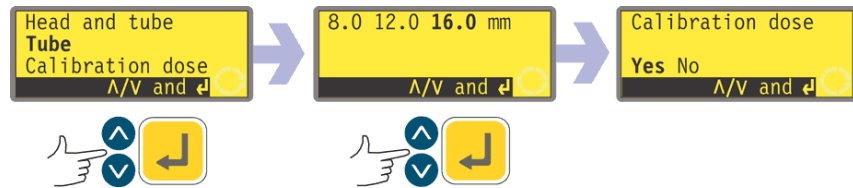

- If **Tube** is selected or a pumphead choice has just been made, the pump displays a list of standard tube sizes that can be used in the pumphead previously identified. An example is shown here.
- Use the **UP** and **DOWN** keys to make a selection. Press **ENTER** to confirm.
- The pump offers to run a calibration dose, as below.

Calibration dose

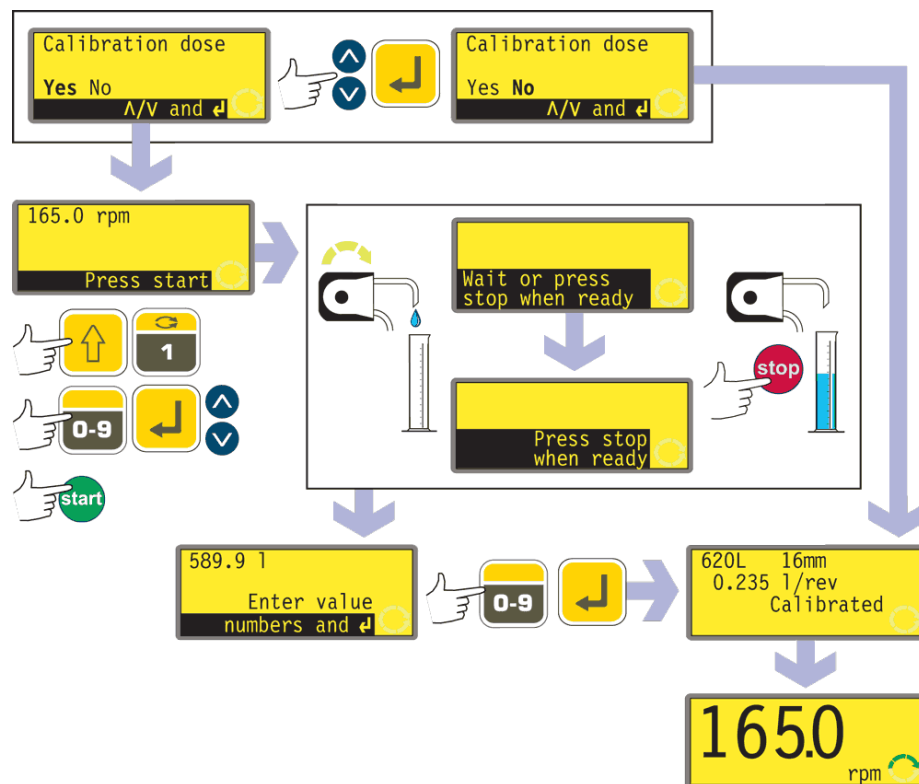

- If **Calibration dose** is selected or if a tube choice has just been made, the pump offers to run a calibration dose. Use the **UP** and **DOWN** keys to choose **Yes** or **No**. Press **ENTER** to confirm. Examples are shown here.
- If **No** is selected after a tube selection has been made (see Tube above), the pump briefly displays a confirmation screen showing current head, tube and flow settings, and displays the main running screen.
- If **Calibration dose** is selected or if **Yes** is selected after a tube selection has been made (see Tube above), the pump displays the speed and direction at which it was last running in manual mode or to which it has just been set and invites the user to press **START**.
- **Note:** it is possible at this point to change the direction of rotation using the **DIRECTION (SHIFT, 1)** key, and to change the speed of rotation using the numeric keys (followed by **ENTER**), or the **UP** and **DOWN** keys, within the minimum and maximum limits that have been set. See 19.13 Set maximum allowed speed and 19.14 Set minimum allowed speed. If the pumphead has been changed at this point, any previously set speed will be over-riden by any lower pumphead maximum speed. The user can reprime the pump before calibration by pressing **SHIFT, 4 (MAX)** (if **Always enabled** was selected while setting up the pump - see 19 Setup).
- Put a measuring container at the pump outlet. Press **START**. The pump runs for 4 minutes, displaying an information screen for 15 seconds and a further information screen for the rest of the 4 minutes. You may stop the calibration dose at any time with the **STOP** key - but allow the pump to run as long as possible to obtain the most accurate calibration. A minimum of 15 seconds is recommended.

- Measure the quantity of fluid dispensed. The pump displays its calculated dose, based on previous calibration data. Use the numeric keys to adjust this reading to match the measured volume. Press **ENTER**. The pump briefly displays the new head, tube and flow settings, and displays the main running screen. Example figures are shown here.



Note: If the pump has been set to display flow rate in units of mass (see 18.8 Flow units), as in this example, the pump displays a screen allowing you to confirm the specific gravity of the duty fluid immediately before the final press on **ENTER**.

Note: Always calibrate after changing pump tubes, fluid, or any connecting pipework. It is also recommended that the pump is recalibrated periodically to maintain accuracy.

Recalibrate

- After pressing **STOP** while the pump is running, use the **UP** and **DOWN** keys to highlight **Recalibrate** and press **ENTER** to confirm.

Alternatively...

Press **SHIFT, 8 (CAL)** while in a dispensing sequence to carry out the recalibration "on the fly".

Note: If **SHIFT, 8 (CAL)** is pressed when a dispensing sequence is not in progress or is paused, *full* calibration will be carried out.

- The pump displays the current dose size. Enter a new value using the numeric keys and press **ENTER** to confirm.
- If the dose size required is within 25% of the previous dose size, the pump accepts the new dose size and offers four choices: **Unpause**, **Restart**, **Recalibrate** and **Exit**. Use the **UP** and **DOWN** keys to make a selection and press **ENTER** to confirm. If the recalibrate sequence was entered by pressing **SHIFT, 8 (CAL)** while a dose was being dispensed, the pump redispenses the running screen and **continues to dispense without waiting for a further command**. The new calibration takes effect when the next full dose is started.
 - If a computer is connected to the pump (620Di only), a status message is output. An example is shown here:

```
Pump address 16
Program name PROG1
Doses completed 521
Date 25.10.05
Time 16:59:00
Flow calibration 6.830 ml/rev
Recalibrated
```

- If the dose size required is more than 25% larger or smaller than the previous dose size, the pump briefly displays a warning message and invites the user to enter a new value.

Note: After highlighting **Recalibrate** and pressing **ENTER** to confirm, or pressing **SHIFT, 8 (CAL)** while a dose is being dispensed, the user can reprime the pump before recalibration by pressing **SHIFT, 4 (MAX)** (if **Always enabled** was selected while setting up the pump - see Setup).

19 Setup

Entry to the Setup menu is from the Main menu and can be limited to users who correctly enter a three-digit security code. If a security code has been set, selecting **Setup** and confirming with the **ENTER** key causes the pump to display the Security code entry sequence. See 19.22 Security code. If no security code has been set, the pump displays the first of seven screens containing the Setup menu.

The Setup menu

The Setup menu occupies five screens. The first two are shown here.

To move from one screen to subsequent screens, repeatedly press **DOWN**. Each item is highlighted in turn until the last item on the screen is highlighted.

A further press on the **DOWN** key displays the next screen of the menu, with the first item highlighted.

Follow the reverse procedure using the **UP** key to move to an item on a previous screen of the menu.

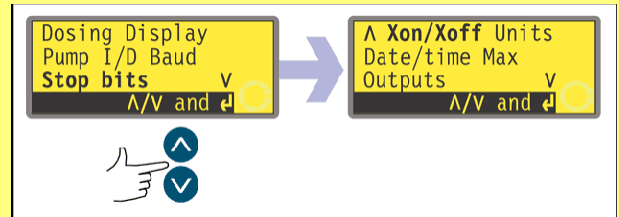

Make a selection using the **UP** or **DOWN** keys and press **ENTER** to confirm your choice.

19.1 Dosing

Items in Dosing sub-menus allow the user to set features of dosing performance.

Dosing flow units

The user can choose revolutions per minute or flowrate as flow units for dosing (as distinct from flow units for manual pumping).

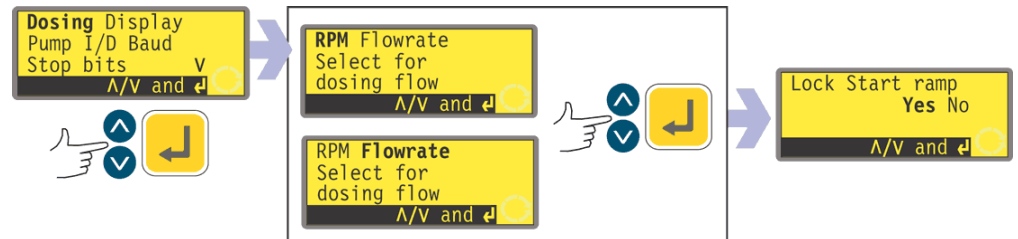

- In the first screen of the Setup menu select **Dosing** Use the **UP** and **DOWN** keys. Press **ENTER** to confirm. The pump offers revolutions per minute or flowrate as dosing flow units.
- Use the **UP** and **DOWN** keys to select **RPM** or **Flowrate**. Press **ENTER** to confirm. The pump records the user's preference and displays the Lock Start ramp screen.
Note: The choice of flowrate units may be made later. See 19.7 Flow units.

Lock start ramp

The user can choose between pre-setting and locking the Start ramp setting so that it cannot be altered by dispense programs during operation - Yes - or leaving it free to be altered by dispense programs during operation - No.

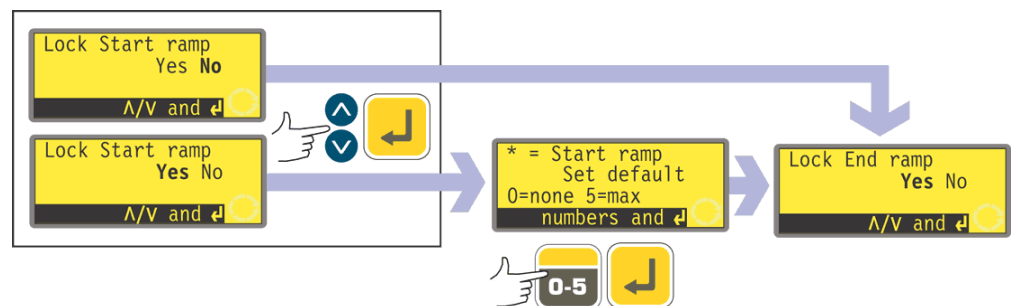

- Use the **UP** and **DOWN** keys to select **Yes** or **No** from the Lock start ramp screen. Press **ENTER** to confirm.
- If **No** is selected, the Start ramp setting is left to dispense programs. The pump displays the Lock end ramp screen.
- If **Yes** is selected, the pump displays the Start ramp pre-setting screen, showing the pre-setting of the last dosing session. When set to 0 the pump starts abruptly at full speed. When set to 5 the pump accelerates softly to full speed.
- If the setting displayed is correct, press **ENTER**. The pump displays the Lock end ramp screen.
- If you wish to change the setting, use the numeric keys to enter the desired setting: **0, 1, 2, 3, 4** or **5**. To quickly return to the starting value, press **SHIFT, 5 (CLEAR)**. If a number greater than 5 is entered, 5 is displayed and entered. Press **ENTER** to confirm. The pump displays the Lock end ramp screen.

Lock end ramp

The user can choose between pre-setting and locking the End ramp setting so that it cannot be altered by dispense programs during operation - Yes - or leaving it free to be altered by dispense programs during operation - No.

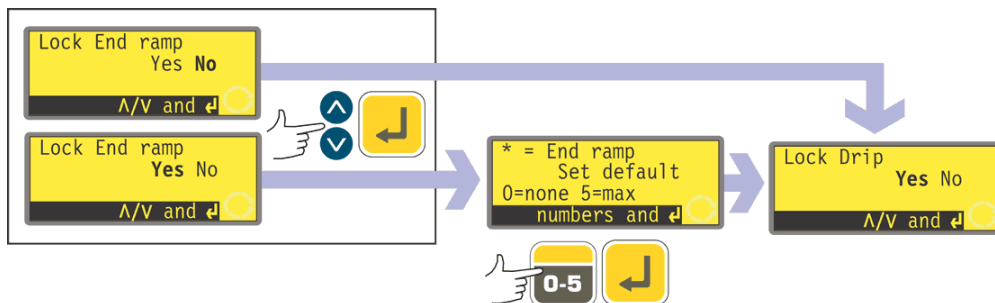

- Use the **UP** and **DOWN** keys to select **Yes** or **No** from the Lock end ramp screen. Press **ENTER** to confirm.
- If **No** is selected, the End ramp setting is left to dispense programs. The pump displays the Lock drip screen.
- If **Yes** is selected, the pump displays the End ramp pre-setting screen, showing the pre-setting of the last dosing session. When set to 0 the pump stops abruptly. When set to 5 the pump decelerates softly to a stop.
- If the setting displayed is correct, press **ENTER**. The pump displays the Lock drip screen.
- If you wish to change the setting, use the numeric keys to enter the desired setting: **0, 1, 2, 3, 4** or **5**. To quickly return to the starting value, press **SHIFT, 5 (CLEAR)**. If a number greater than 5 is entered, 5 is displayed and entered. Press **ENTER** to confirm. The pump displays the Lock drip screen.

Lock drip

The user can choose between pre-setting and locking the Drip setting so that it cannot be altered by dispense programs during operation - Yes - or leaving it free to be altered by dispense programs during operation - No.

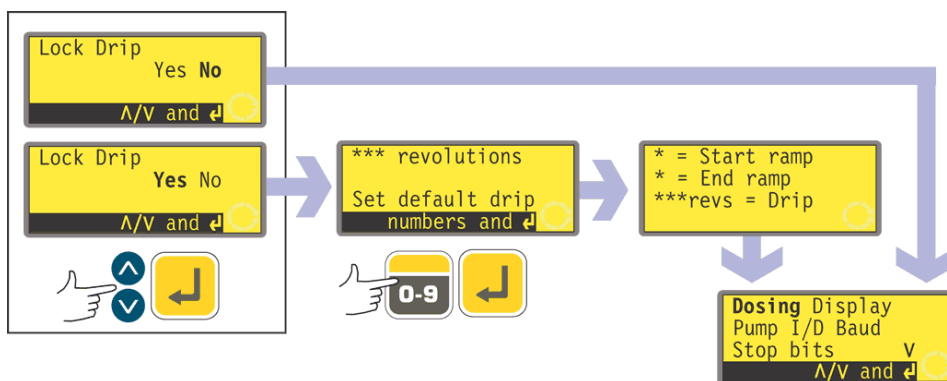

- Use the **UP** and **DOWN** keys to select **Yes** or **No** from the Lock drip screen. Press **ENTER** to confirm.
- If **No** is selected, the drip setting is left to dispense programs. The pump redisplay the first screen of the Setup menu.
- If **Yes** is selected, the pump displays the Drip pre-setting screen, showing the pre-setting of the last dosing session: from 0 to 1.0 (zero to one revolution) at one-tenth of a revolution intervals.
- If the setting displayed is correct, press **ENTER**. The pump confirms the Start ramp, End ramp and Drip settings for four seconds and redisplay the first screen of the Setup menu.

- If you wish to change the setting, use the numeric keys to enter the desired setting: zero revolutions to 1 revolution at 0.1 revolution intervals. To quickly return to the starting value, press **SHIFT, 5 (CLEAR)**. If a number greater than 1.0 is entered, 1.0 is displayed and entered. Press **ENTER** to confirm. The pump confirms the Start ramp, End ramp and Drip settings for four seconds and redisplay the first screen of the Setup menu.

19.2 Display

The pump can display two default screens in manual mode: revolutions per minute, or flowrate in a choice of units.

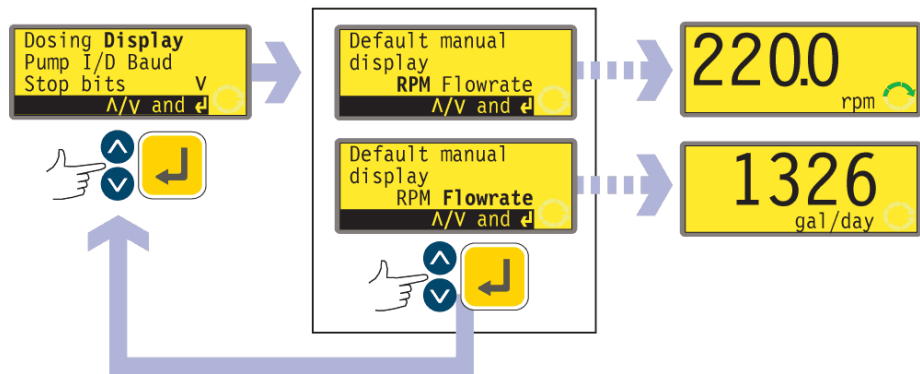

- In the first screen of the Setup menu select **Display** using the **UP** and **DOWN** keys. Press **ENTER** to confirm your choice.
- The pump displays a screen allowing you to choose the format of the manual mode main screen. Use the **UP** and **DOWN** keys to choose and press **ENTER** to confirm your decision.
- If you choose **Flowrate** and you have not calibrated the pump since switching it on, a warning screen is displayed for 4 seconds. The warning does not appear if the display screen formats are cycled again, unless the pump has been switched off in the mean time.
- The pump redisplay the first screen of the Setup menu.
- When the pump next runs, the manual mode main screen will display pump activity in rpm, or flowrate (in the units you chose - see 19.7 Flow units), according to your choice. Examples are shown here.

Alternatively ...

- In the manual mode main screen, repeatedly press **ENTER** to cycle the display between rpm or flowrate (in the units you chose - see 19.7 Flow units) according to your choice. This cycle operates if the pump is running and if it is stopped. While the pump is running, you can cycle the display in the same way by repeatedly pressing **START**. In both cases, if you have not calibrated the pump since switching it on, a warning screen is displayed for 4 seconds before the flowrate screen appears. The warning does not appear if the display screen formats are cycled again, unless the pump has been switched off.
- The pump redisplay the first screen of the Setup menu.

19.3 Pump I/D

The 620Di pump can be individually controlled under RS232 as one of up to 16 pumps. The 620DiN pump can be individually controlled under RS485 as one of up to 32 pumps. First the pump must be given its identity number.

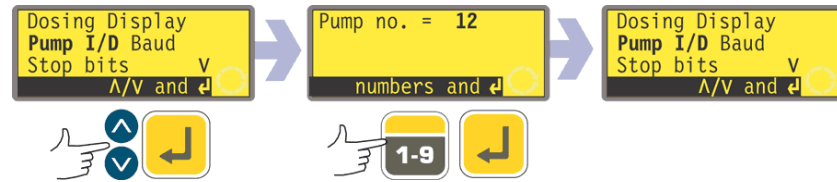

- In the first screen of the Setup menu select **Pump I/D** using the **UP** and **DOWN** keys. Press **ENTER** to confirm your choice.
- The pump displays a screen allowing you to change the pump's identity number. Use the numeric keys to enter a new number in the display and press **ENTER** to confirm your decision. An example is shown here.
- The pump displays the first screen of the Setup menu.

19.4 Baud

The pump can be set to communicate with control devices at a choice of baud rates.



- In the first screen of the Setup menu select **Baud** using the **UP** and **DOWN** keys. Press **ENTER** to confirm your choice.
- The pump displays a screen allowing you to change the pump's baud rate. Use the **UP** and **DOWN** keys to select **1200**, **2400**, **4800** or **9600** and press **ENTER** to confirm your decision.
- The pump displays the first screen of the Setup menu.

19.5 Stop bits

The pump can be set to communicate with control devices at a choice of stop bits settings.

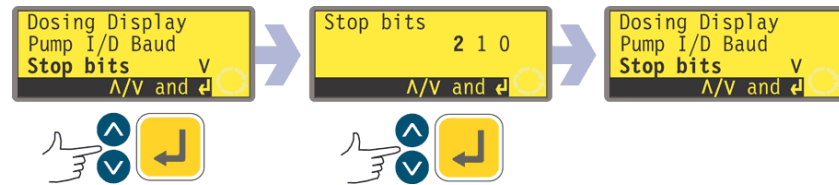

- In the first screen of the Setup menu select **Stop bits** using the **UP** and **DOWN** keys. Press **ENTER** to confirm your choice.
- The pump displays a screen allowing you to change the pump's stop bits setting. Use the **UP** and **DOWN** keys to select **2**, **1**, or **0** and press **ENTER** to confirm your decision.
- The pump displays the first screen of the Setup menu.

19.6 Xon/Xoff

The pump can be set to communicate with control devices using Xon/Xoff flow control.

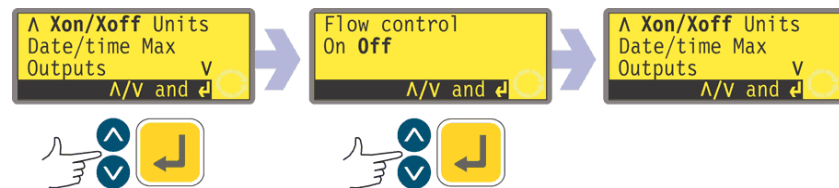

- In the second screen of the Setup menu select **Xon/Xoff** using the **UP** and **DOWN** keys. Press **ENTER** to confirm your choice.
- The pump displays a screen allowing you to set flow control on or off. Use the **UP** and **DOWN** keys to choose and press **ENTER** to confirm your decision.
- The pump displays the second screen of the Setup menu. .

19.7 Flow units

The pump can display its flow rate in metric (SI) or US (imperial) units of volume or mass.

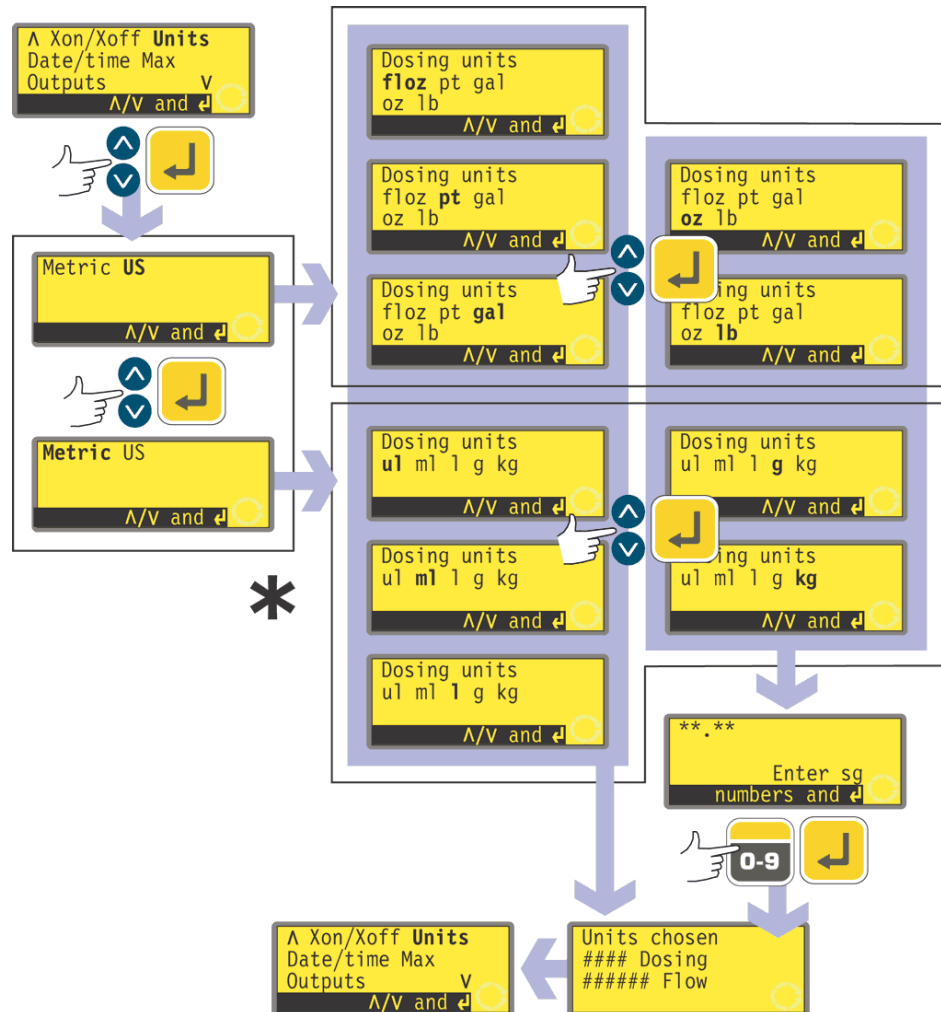

* **Note:** "ul" shown here and used on pump displays represents " μ l" (microlitres).

- In the second screen of the Setup menu select **Units** using the **UP** and **DOWN** keys. Press **ENTER** to confirm.
- The pump displays a screen offering Metric or US. Use the **UP** and **DOWN** keys to choose **Metric** or **US**. Press **ENTER** to confirm.
- If you chose Metric, the pump offers a choice of units. Use the **UP** and **DOWN** keys to choose **μ l, ml, l, g** or **kg** and press **ENTER** to confirm.
- If you chose US, the pump offers a choice of units. Use the **UP** and **DOWN** keys to choose **floz, pt, gal, oz** or **lb** and press **ENTER** to confirm.
- If you chose a volumetric flow rate from either screen, a confirmation screen appears briefly and the pump redisplay the second screen of the Setup menu.
- If you chose a mass flowrate from either screen, the pump asks for the specific gravity of the fluid to be pumped. Use the numeric keys to enter a value between 0.01 and 15. If a number greater than 15 is entered, 15 is displayed and entered. Press **ENTER** to confirm your decision. Press **STOP** if you decide to make a different choice of units.
- A confirmation screen appears briefly and the pump redisplay the second screen of the Setup menu.

19.8 Date and time

To record dosing sessions the pump's real-time clock needs to know the date and time.



- In the second screen of the Setup menu select **Date/time** using the **UP** and **DOWN** keys. Press **ENTER** to confirm. The pump displays any previous setting.
- If the setting displayed is correct, press **ENTER**. The pump redisplay the second screen of the Setup menu.
- If you wish to change the setting, use the **UP** and **DOWN** keys to enter the current date (two digits), month (three letters), year (four digits), hour, minute and second (all two digits), pressing **ENTER** to confirm each one.
- When **ENTER** is pressed to confirm the seconds, the pump redisplay the second screen of the Setup menu.

19.9 Max key operation

The pump must be primed - its tube filled with duty fluid - if it is to dispense immediately. This is done by pressing and holding **SHIFT, 4 (MAX)** to operate the pump at full speed until duty fluid reaches the discharge port. Priming ceases when **SHIFT, 4 (MAX)** is released. **SHIFT, 4 (MAX)** can be set to function in a narrow or a wide range of circumstances.

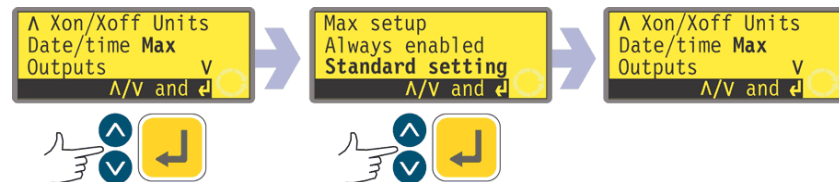

- In the second screen of the Setup menu select **Max** using the **UP** and **DOWN** keys. Press **ENTER** to confirm.
 - Use the **UP** and **DOWN** keys to select **Standard setting** if you want **SHIFT, 4 (MAX)** to invoke priming only when the pump is in Manual mode or Dose mode while waiting for a press on **START** to begin dosing. Select **Always enabled** if you want **SHIFT, 4 (MAX)** to invoke priming when the pump is in Manual mode, Calibrate or Dose mode while stopped. Press **ENTER** to confirm. The pump redisplay the second screen of the Setup menu.
- Note:** **SHIFT, 4 (MAX)** has no effect in Network or Setup mode.

19.10 Outputs

DiN

The 620DiN pump offers four relay status outputs. See 12 Switching the pump on for the first time for initial start-up defaults. Each of seven parameters can be configured to any output, or more than one output.

Di

The 620Di pump offers four digital status outputs. See 12 Switching the pump on for the first time for initial start-up defaults. Each of seven parameters can be configured to any output, or more than one output.

DiN, Di

The parameters are:

Run/stop

Provides a status output to indicate whether the pumphead is running or stopped at all times. When running at Orpm, the run/stop output indicates running.

General alarm

Provides an alarm output when any system error condition occurs except: leak detected; analogue signal out of range; analogue over-signal; analogue no signal.

Direction

Provides a status output to indicate which direction the pump is set to run in.

Leak detected

When used with a leak detector, this output provides an alarm when the pump has been automatically switched off following tube failure.

Net / man

Provides a status output to indicate whether the pump is under network control or manual control.

Dose

Provides a status output to indicate whether the pumphead is running or stopped while dosing is taking place.

Batch

Provides a status output to indicate whether a dispense batch is in progress.

Di

Output 1 and output 2 are available in two formats:

- From pins 10 and 11, lower D-connector, as 5V TTL signals.
- From pins 10 and 11, upper D-connector, as open collector logic outputs.

Output 3 and output 4 provide open collector logic outputs from pins 13 and 12, upper D-connector, respectively.

A supply voltage from the pump (5V, 10V, 12V) or user-supplied up to 30V to pin 22, upper D-connector, provides the voltage level for these logic status outputs.

DiN

Outputs 1-4 are available as single-pole change-over relay contacts: Relay 1, 2, 3 and 4. Connect to the normally open or normally closed contacts of the relay as required and configure the pump's software accordingly. See below in this section.

Note: The maximum rating on the relay contacts of this pump is 30VDC; maximum load 30W.

DiN, Di

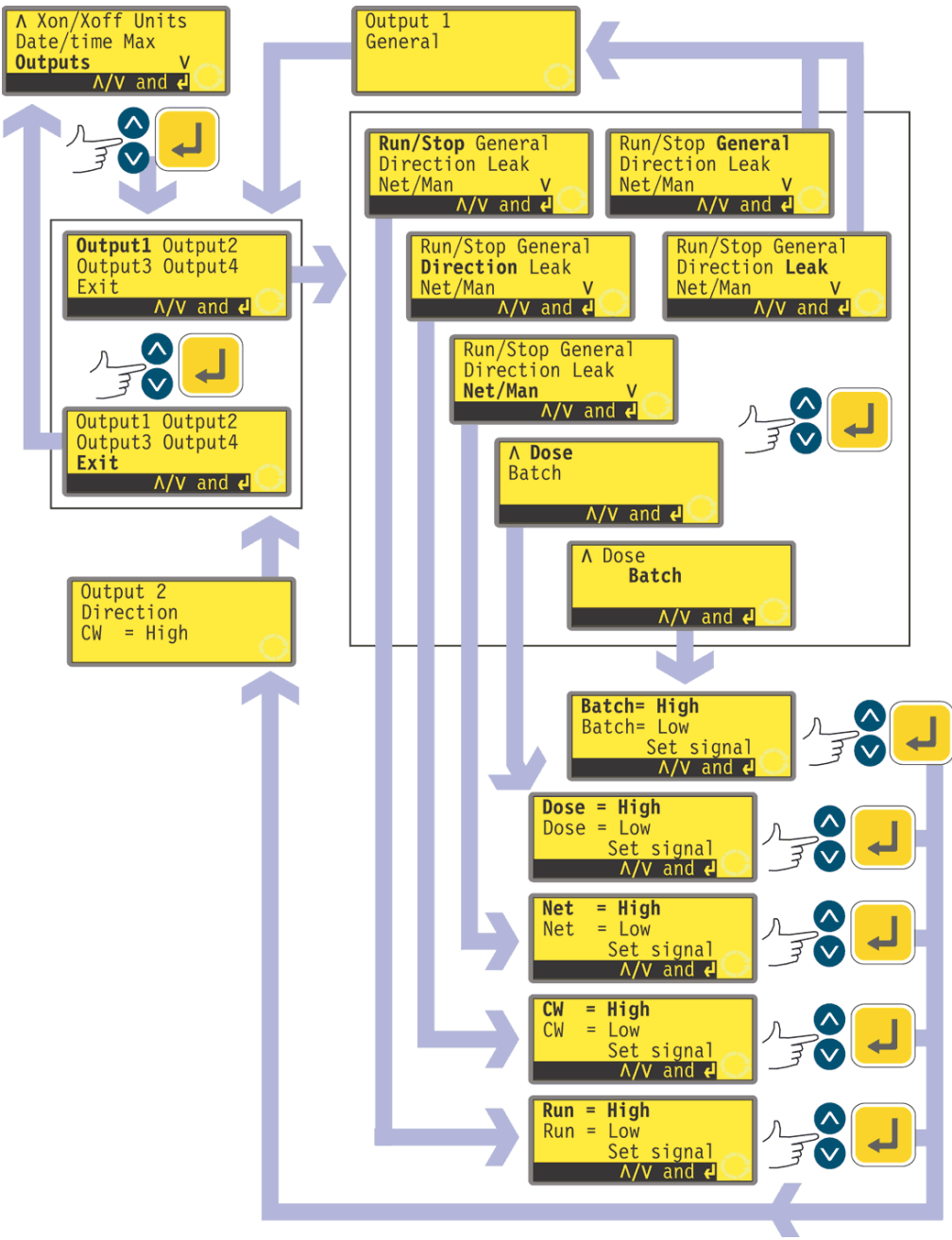

- In the second screen of the Setup menu select **Outputs** using the **UP** and **DOWN** keys. Press **ENTER** to confirm.
- The pump displays the Output selection screen, from which you can configure each of the four outputs, or exit this menu. Use the **UP** and **DOWN** keys to choose and press **ENTER** to confirm.

- If **Output 1** is chosen, the pump displays the Outputs menu.

The Outputs menu occupies two screens.

To move from one screen to subsequent screens, repeatedly press DOWN. Each item is highlighted in turn until the last item on the screen is highlighted.

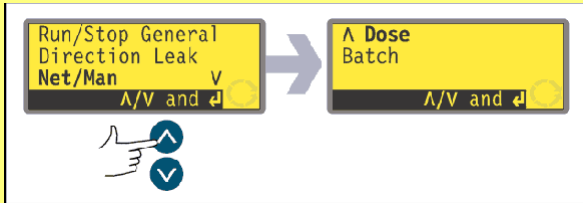

A further press on the DOWN key displays the next screen of the menu, with the first item highlighted.

Follow the reverse procedure using the UP key to move to an item on the first screen of the menu.

- Selecting **General** or **Leak** using the **UP** and **DOWN** keys and confirming the choice by pressing **ENTER** configures that option to Output 1, displays a confirmation screen, and returns the user to the Output selection screen.
- Selecting **Run/Stop**, **Direction**, **Net/Man**, **Dose** or **Batch** using the **UP** and **DOWN** keys and confirming the choice by pressing **ENTER** displays screens allowing the user to configure Run to **High** or **Low**, Clockwise to **High** or **Low**, Net to **High** or **Low**, Dose to **High** or **Low** and Batch to **High** or **Low** respectively. Choose using the **UP** and **DOWN** keys and press **ENTER** to confirm. The option chosen is configured to Output 1. The pump displays a confirmation screen, and returns the user to the Output selection screen. An example is shown here.
- The user can configure **Output 2**, **Output 3** and **Output 4** in the same way, or choose **Exit**.
- If **STOP** is pressed during configuration, the previous setting for the output is retained and the pump redisplay the Output selection screen.
- If **Exit** is chosen, the pump returns the user to the second screen of the Setup menu.

Outputs 1-4: First-time start-up defaults		
Output 1	Dose	= high
Output 2	Direction	Clockwise = high
Output 3	Net/Man	Net = high
Output 4	General alarm	

19.11 Remote stop

DiN

The 620DiN pump can be started and stopped with a remote switch between the 5V terminal and the i/p terminal of the Run/stop input, using an open=run or open=stop command sense. It also operates with a logic input between 5V and 24V on the i/p terminal of the Run/stop input. If remote switching is disabled, neither the remote run/stop nor direction signal inputs will affect the pump state.

Di

The 620Di pump can be started and stopped with a remote switch between pin 7 and pin 19 using an open=run or open=stop command sense. It also operates with

a logic input between 5V and 24V on pin 7. If remote switching is disabled, neither the remote run/stop nor direction signal inputs will affect the pump state.

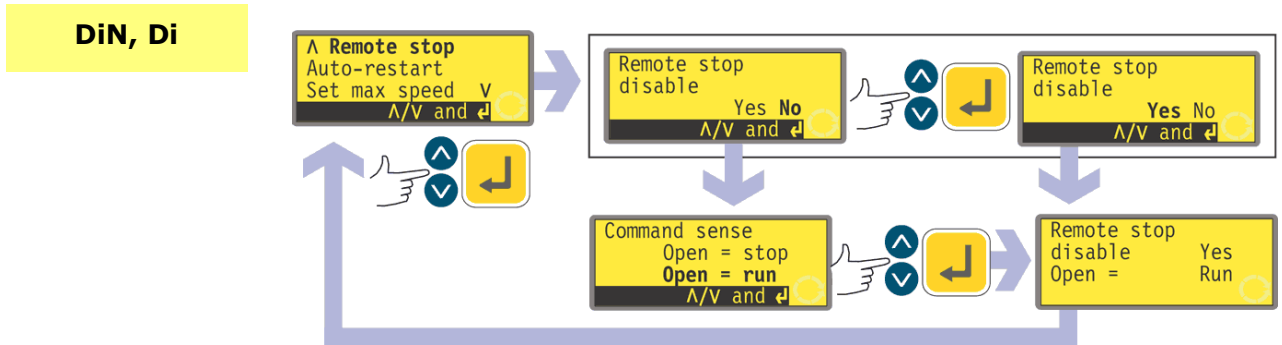

- In the third screen of the Setup menu select **Remote stop** using the **UP** and **DOWN** keys. Press **ENTER** to confirm.
- The pump displays a screen allowing the user to disable the remote stop feature. Use the **UP** and **DOWN** keys to choose **Yes** or **No** and press **ENTER** to confirm.
- If **No** is chosen, the pump asks the user to make a further choice: whether the pump is required to run on an open or closed remote switch: **Open=stop** or **Open=run**. Choose using the **UP** and **DOWN** keys and press **ENTER** to confirm. The pump briefly displays a confirmation screen and returns the user to the third screen of the Setup menu.
- If **Yes** is chosen, the pump briefly displays a confirmation screen and returns the user to the third screen of the Setup menu. Examples are shown here.
Note: The confirmation screen indicates whether Remote stop is enabled or disabled, and displays the command sense of the remote control switch **even if Remote stop has been disabled**.

Alternatively ...

- To toggle the sense of the remote run / stop control between open=stop and open=run: stop the pump. Turn off the mains power switch at the rear of the pump.
- Hold down the **STOP** key and the **1 (DIRECTION)** key, and turn on the mains power switch. The **UP** and **DOWN** keys can then be used to toggle the sense of remote run / stop control between open=stop and open=run.
 See 20.3 Run / stop input.

19.12 Auto-restart

This pump offers an auto-restart feature. If active on power loss, it restores the pump when power returns to the operating state it was in when power was lost. It does not operate when powering down in the middle of a dose: when the pump is restarted, it will await a press on the **START** key to begin the interrupted dose again. Auto-restart is retained while the pump is switched off. When the pump starts running, look for the ! symbol on the display. This symbol indicates that the pump is set for auto-restart.

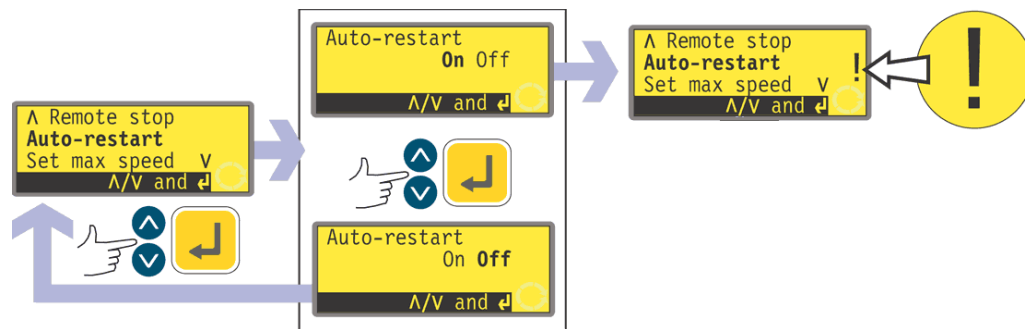

- In the third screen of the Setup menu select **Auto-restart** using the **UP** and **DOWN** keys. Press **ENTER** to confirm.
- The pump displays a screen allowing the user to activate auto-restart. Use the **UP** and **DOWN** keys to choose **On** or **Off** and press **ENTER** to confirm.
- If **Off** is chosen, the pump returns the user to the third screen of the Setup menu. The auto-restart facility will not operate.
- If **On** is chosen, the pump returns the user to the third screen of the Setup menu, where an exclamation mark (!) is now visible. This mark confirms that the auto-restart feature is in place and will operate the next time power is lost and restored.

Alternatively ...

- Stop the pump. Turn off the mains power switch at the rear of the pump.
- Hold down the **START** key and turn on the mains power switch. The ! symbol shows on the display.
- Start the pump. If the mains supply is interrupted the pump will automatically restart when the mains power returns.
- To remove auto-restart switch off the mains power at the rear of the pump. Hold down the **STOP** key and turn the mains power switch on. The ! symbol does not appear.



Do not use auto-restart for more than 100 starts per hour. We recommend remote control where a high number of starts is required.

19.13 Set maximum allowed speed

The maximum allowed speed of the drive defaults to 165rpm. It is possible to set this limit at any speed down to 1rpm as long as the minimum allowed speed is at least 1rpm less, or up to 265rpm; however, see 8.1 Pressure capability for use above 165rpm.

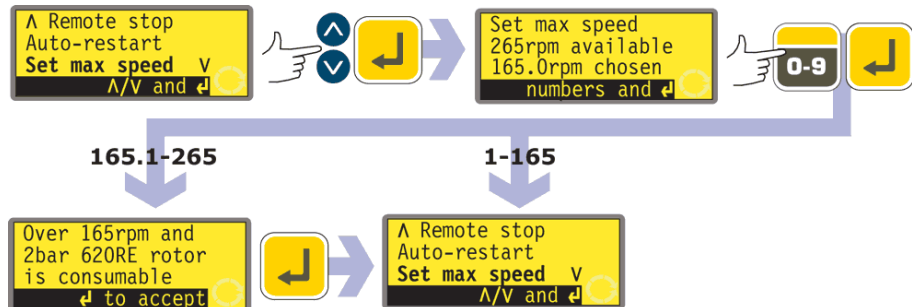

- In the third screen of the Setup menu select **Set max speed** using the **UP** and **DOWN** keys. Press **ENTER** to confirm.
- The pump displays a screen allowing the user to set the maximum speed of the pump equal to or lower than the maximum available. Use the numeric keys to set the maximum allowed speed and press **ENTER** to confirm.
- The pump returns the user to the third screen of the Setup menu, via a warning screen requiring the user to press **ENTER** if he selected a speed greater than 165rpm.

19.14 Set minimum allowed speed

The minimum allowed speed of the drive defaults to 0rpm. It is possible to set this limit at any speed up to 264rpm, as long as the maximum speed is at least 1rpm greater.



- In the fourth screen of the Setup menu select **Set min speed** using the **UP** and **DOWN** keys. Press **ENTER** to confirm.
- The pump displays a screen allowing the user to set the minimum speed of the pump equal to or higher than the minimum available. Use the numeric keys to set the minimum allowed speed and press **ENTER** to confirm the figure.
- The pump returns the user to the fourth screen of the Setup menu.

19.15 Scrolling

The pump's speed can be set, up to the maximum allowed speed and down to the minimum allowed speed, by pressing the numeric keys or by using the **UP** and **DOWN** keys.

The numeric keys allow the user to select a speed in increments of one-tenth of a revolution per minute (or the equivalent in flow rate if the pump has been configured to display its performance in units of flow).

The **UP** and **DOWN** keys allow the speed to be set in increments of the user's choice: one-tenth of a revolution per minute; one half of a revolution per minute; one, two, five or ten revolutions per minute (or their equivalents in flow rate if the pump has been configured to display its performance in units of flow). Each press on **UP**, for example, offers a speed one increment greater than the current speed.

Note: For 0.1rpm, 0.5rpm and 1rpm settings, the increments increase progressively as long as the **UP** and **DOWN** keys are pressed.



- In the fourth screen of the Setup menu select **Scrolling** using the **UP** and **DOWN** keys. Press **ENTER** to confirm.
- The pump displays a screen allowing the user to set the **UP** and **DOWN** keys' scrolling increment. Use the **UP** and **DOWN** keys to choose **0.1**, **0.5**, **1.0**, **2.0**, **5.0** or **10.0**. Press **ENTER** to confirm your choice.
- The pump returns the user to the fourth screen of the Setup menu.

Note: If the maximum allowed speed has been set to a figure which is not a multiple of the chosen increment, the last active press on **UP** raises the speed to that maximum rather than to the next multiple of the chosen increment. Similarly, if the pump is running at a speed which is not a multiple of the chosen increment, the first press on **UP** raises the speed to the next multiple of the chosen increment.

19.16 Backlight

The pump's display can be illuminated or not according to choice.

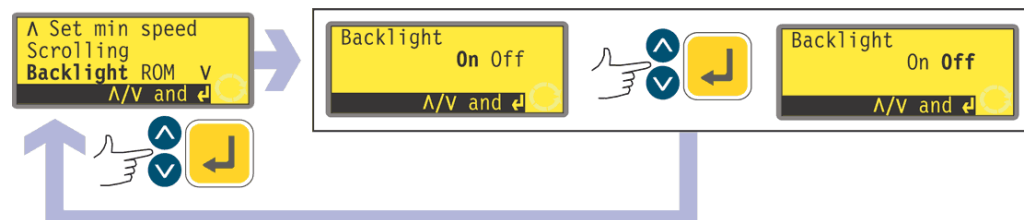

- In the fourth screen of the Setup menu select **Backlight** using the **UP** and **DOWN** keys. Press **ENTER** to confirm.
- The pump displays a screen allowing the user to switch the display backlight on or off. Use the **UP** and **DOWN** keys to choose **On** or **Off** and press **ENTER** to confirm.
- The pump returns the user to the fourth screen of the Setup menu. The display is now illuminated or not according to the user's decision.

Alternatively ...

- To turn the backlight off: press **STOP** and **DOWN** together while the pump is stopped.
- To turn the backlight on: press **STOP** and **UP** together while the pump is stopped.

19.17 ROM

The pump can display its software version, model number and pump speed.



- In the fourth screen of the Setup menu select **ROM** using the **UP** and **DOWN** keys. Press **ENTER** to confirm.
- The pump displays the software version, model number (620Di for 620Di and 620DiN) and the maximum allowed pump speed for four seconds (an example is shown here), then returns the user to the fourth screen of the Setup menu. It also displays a checksum: CHK 123, for example. This may be required if reporting pump performance to the Flexicon service department.

Alternatively ...

Press **1 (DIRECTION)** and **DOWN** together in Manual mode to interrupt the display and show the pump's ROM version for four seconds.

Di

19.18 Pin out details

Selecting **Pin out details** causes the pump to display an information screen and then its preset pin and voltage details under 13 headings: **Direction enable, Direction input, Run/Stop input, Leak input, Dose input, Output 1, Output 2, Output 3, Output 4, Supply, 0 volts, Earth** and **Others**. No user input is available in this section; it displays information only.

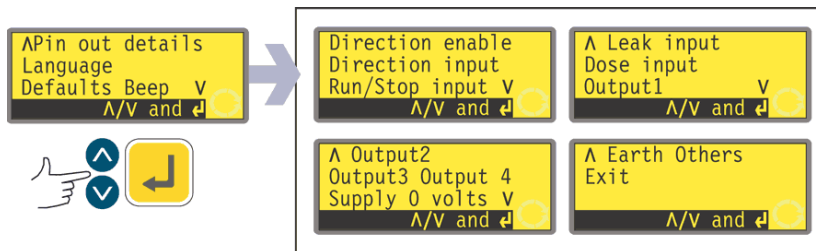

- In the fifth screen of the Setup menu select **Pin out details** using the **UP** and **DOWN** keys. Press **ENTER** to confirm.

The Pin out details menu

The Pin out details menu occupies four screens. The first two are shown here.

To move from one screen to subsequent screens, repeatedly press **DOWN**. Each item is highlighted in turn until the last item on the screen is highlighted. A further press on the **DOWN** key displays the next screen of the menu, with the first item highlighted.

Follow the reverse procedure using the **UP** key to move to an item on a previous screen of the menu.

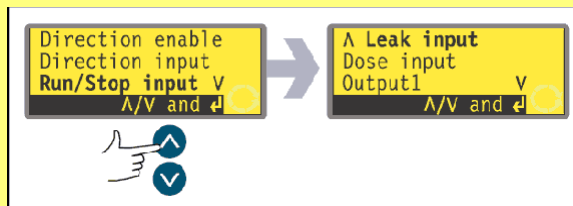

- Use the **UP** or **DOWN** keys to make a selection. Press **ENTER** to confirm.
- The information on pin outs duplicates the details described in this instruction manual under Automatic control wiring.
- The screens available are all presented in a similar manner. For example, on selecting **Run/Stop input**, the following screen is displayed:

```
Lower connector
7 Signal
18 0V 19/23 5V
max24V
```

This indicates that the analogue input signal must be applied to pin 4 of the lower D-connector at the rear of the pump, where 0 volts is available on pin 16. If the analogue input is configured for a 4-20mA signal, the maximum permitted voltage is 5 volts; if the analogue input is configured for a 0-10V or 1-5V signal, the maximum permitted voltage is 10 volts.

Pressing **STOP** or **ENTER** in any Pin out information screen returns the user to the appropriate Pin out menu screen.

Note: The information available on selecting **Supply** and **Others** is presented on two screens each. Pressing **DOWN** when the last item of the first screen of each is highlighted causes the second screen to appear with its first item highlighted. **UP** performs a similar function.

To leave the Pin out menu screens

- Cycle through the Pin out menu screens until the fourth screen is displayed. Use the **UP** and **DOWN** keys to select **Exit** and press **ENTER** to confirm.

Alternatively ...

- Repeatedly press **STOP** to go back level by level until the Main menu is displayed.

Pin out information is not relevant to the 620DiN IP66/NEMA 4X pump. Selecting Pin out details causes the pump to display a warning screen and redisplay the main menu.

19.19 Language

The pump can be set to operate in several languages.



- In the fifth screen of the Setup menu select **Language** using the **UP** and **DOWN** keys. Press **ENTER** to confirm.
- In the next screen, choose a language using the **UP** and **DOWN** keys. Press **ENTER** to confirm. The pump redisplay the fifth Setup screen in your chosen language. All screens will subsequently appear in your chosen language.

19.20 Defaults

All the pump's user-set data can be reset to factory defaults.

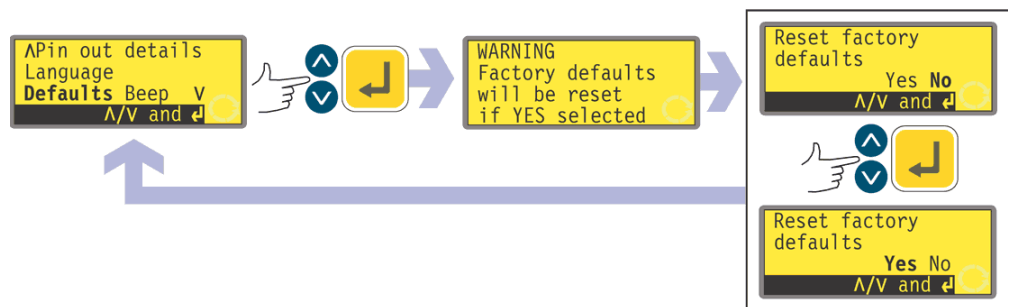

- In the fifth screen of the Setup menu select **Defaults** using the **UP** and **DOWN** keys. Press **ENTER** to confirm.
- A warning is displayed for four seconds, and the pump asks the user to confirm that factory defaults are to be reset. Use the **UP** and **DOWN** keys to choose **Yes** if you wish the pump to reset all user-set data back to factory defaults (see 12 Switching the pump on for the first time); or **No** if you do not wish to do this. Press **ENTER** to confirm. If **Yes** was chosen, the pump resets its factory defaults and redisplay the fifth Setup screen. If **No** was chosen, the pump makes no changes to its setup and redisplay the fifth Setup screen.

19.21 Beep

The pump keypad can operate silently or indicate a positive key-press with a beep sound.

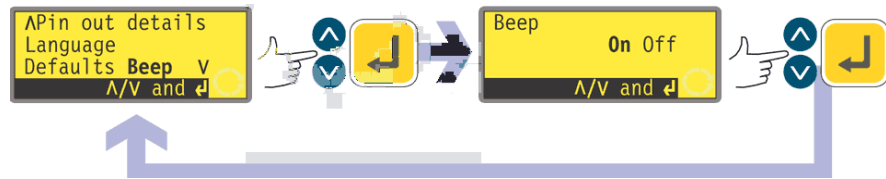

- In the fifth screen of the Setup menu select **Beep** using the **UP** and **DOWN** keys. Press **ENTER** to confirm.
- In the next screen, use the **UP** and **DOWN** keys to choose **On** or **Off**. Press **ENTER** to confirm your decision. The pump redisplay the fifth Setup screen.

Alternatively ...

- To toggle the sound on and off, stop the pump. Turn off the mains power switch at the rear of the pump.
- Depress the **UP** and **1 (DIRECTION)** keys while switching on the mains power switch at the rear of the pump.

19.22 Security code

Access to the pump's Setup and Calibration menus, direction control and keypad lock can be restricted to those who correctly enter a three-digit security code: the main code. A secondary user code can be set, which permits PIN access to calibration, direction and keypad lock, but blocks access to Setup. See 19 Setup, 18 Calibrate, 14.3 Direction and 14.4 Keypad lock.

The codes must first be set.

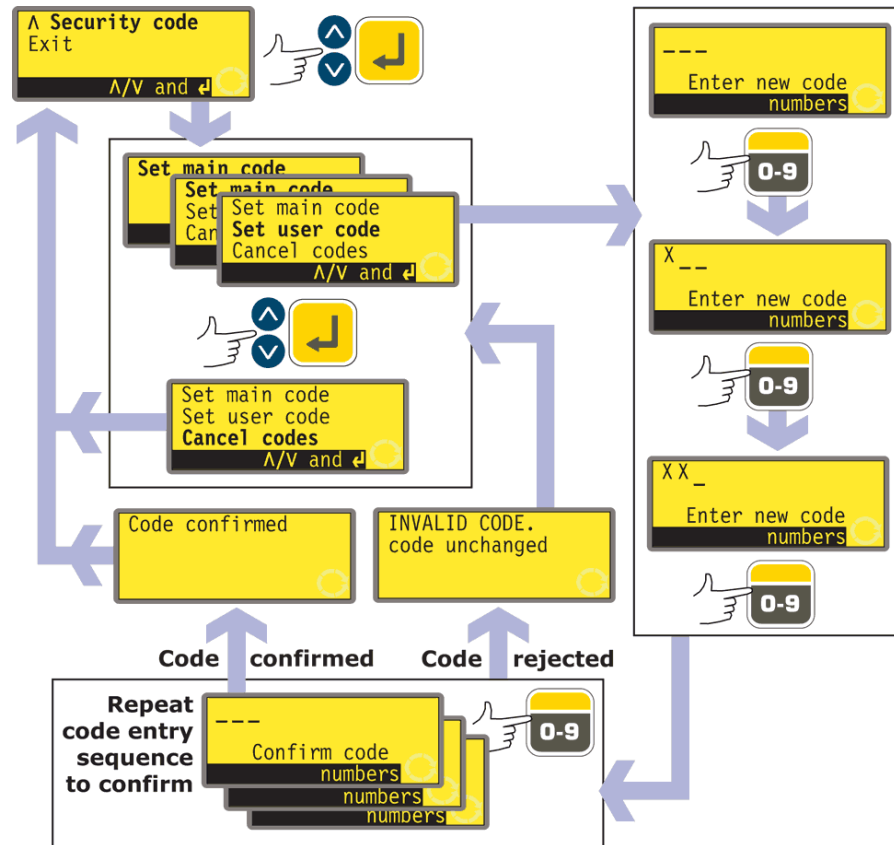

- In the sixth screen of the Setup menu select **Security code** using the **UP** and **DOWN** keys. Press **ENTER** to confirm.
- If no code has been set, a screen is displayed inviting the user to set a main code. Press **ENTER** to proceed (or **STOP** to return to the sixth screen of the Setup menu).
- If a main code has been set, a screen is displayed inviting the user to set a new main code, to set a user code (or a new user code if one has already been set), or to cancel all codes. Choose **Set main code**, **Set user code** or **Cancel codes** using the **UP** and **DOWN** keys. Press **ENTER** to confirm your choice.
- If you chose **Cancel codes**, any codes previously set are cancelled and access to the pump is not restricted.
- If you chose **Set main code** or **Set user code**, the pump displays a screen with three blank spaces for digits and the instruction "Enter new code". Use the numeric keys to enter three digits. The pump displays a similar three-digit entry screen and the instruction "Confirm code".
- Repeat the digit-entry sequence.
- If the second three-digit code entered differs from the first, or if the digits chosen as a user code are the same as those already set as a main code, the pump briefly displays an error message and redisplay the set code options screen.
- If the codes tally and, for a user code, if there is no clash with a previously set

main code, the pump briefly displays a confirmation message and redisplay the sixth Setup screen. Access to the Setup and Configuration menus, direction control and keypad lock is now protected by the new security code.

- If **STOP** is pressed during code entry, the pump returns the user to the sixth Setup screen. If **STOP** is pressed during code confirmation, the pump returns the user to the first digit-entry screen.

Note: A user code cannot be set unless a main code has previously been set. If you wish to cancel only a user code, you must use **Cancel codes** to cancel both user and main codes, then use **Set main code** to set a new main code.

Note: If a code has been set but forgotten, it is still possible to access the Setup screens to cancel the code or reset it to another three-digit number. Contact your supplier or Flexicon Technical support for the bypass sequence.

19.23 Exit



- In the sixth screen of the Setup menu select **Exit** using the **UP** and **DOWN** keys. Press **ENTER** to confirm.
- The user is returned to the Main menu.

20 Automatic control wiring using the 620N module

Interfacing the pump with other devices is by means of screw-terminal connectors within the 620N watertight module at the rear of the pump. Suitable cable must be passed into the module through one or more watertight cable glands and connected appropriately. The module must be removed to allow this.



It is important to check that the pump's voltage setting matches the supply. The voltage selection switch is on the rear panel of the drive. The module must be removed (and replaced) to allow it to be checked.

20.1 620N module removal and replacement

To remove the 620N watertight module:

The module is secured to the back of the drive unit by six M5x12 Pozidriv counter-sunk stainless steel screws.



- Remove the six screws using a suitable crosspoint screwdriver, leaving the top centre screw till last. Even when all screws have been removed, the sealing strip may cause the module to adhere to the drive. If so, a gentle tap will free it. Do not use a tool to lever it off.
- The sealing strip should be retained within its channel on the face of the module. The transparent on/off switch cover should be retained on its flange on the face of the module. Check the integrity of the seal and the transparent on/off switch cover. If either is damaged, it must be renewed to maintain ingress protection.
- If necessary, unplug the two 25-way D-connectors linking the module to the pump drive. If necessary, remove the module's earth link from the back of the drive. However, the link is long enough to allow the module to fold back to give access to the the circuit board inside and to the back of the drive.

To replace the 620N watertight module:



- Check that the fuse in the fuseholder (ringed) does not need to be replaced. Check that the voltage selector switch is correctly set.
- Check that the sealing strip is fully in its channel on the face of the module.
- Attach the module's earth link wire. Replace and tighten its screw to 2Nm.
- Push home the female (upper) and male 25-way D-connectors.
- Hold the module in place. Do not disturb the seal or pinch the earth link wire or D-connector ribbon cables, and screw in the retaining screws (top centre first). Tighten to 2.5Nm.

Note: The 620N module must be properly fitted using all six screws. Without them, the screw holes may corrode and IP66 (NEMA4X) protection will be compromised.

20.2 Wiring up

It is the user's responsibility to ensure the pump's safe and reliable operation under remote and automatic control.

This pump's 0V lines are commoned and mains transformer-isolated from ground (floating ground). It can be connected to isolated 0V or grounded 0V interfaces.

Cable entry to the module is via up to four watertight cable glands. These may be fitted in place of the plugs which seal the module when the pump is shipped.

The number of glands needed depends on the number of connection cables required and the convenience of the installer. As standard, four M16 cable glands are provided with the pump.



Recommended control cables must be used for the terminal blocks: metric = 0.14sq mm - 2.5sq mm solid and 0.14sq mm - 1.5sq mm stranded. USA = 26AWG - 14AWG solid and 26AWG - 16AWG stranded. Cable: circular. Max/min outside diameter to ensure a seal when passed through the standard gland: 9.5mm-5mm. **The cable section must be circular to ensure a seal.**



The recommended cable and cable glands must be used for the IP66 (NEMA 4X) version of this pump; otherwise ingress protection may be jeopardised.

For EMC protection, shielded control cable should be used. The shielding should be terminated to one of the pcb mounting screws or to the adjacent spade connection (where fitted).

For improved EMC protection in extremely noisy environments, shielded cable may be used in conjunction with watertight EMC metal cable glands. These must be earthed to the module by adding an M16x1.5 nut with serrated edges to ensure proper contact with the inside of the module. It is necessary to remove the module's circuit board to access the interior of the module: it is held in place by two fixing screws which can be removed and replaced with a cross-point screwdriver. Take normal anti-static precautions when handling printed circuit boards.

Suitable cables for general-purpose use: 300V with extra premium grade PVC jacket with good flame and moisture resistance.

Suitable cables for industrial use: 300V extra-rugged polyurethane grade jacket with resistance to oils, fuels, solvents and water.

For convenience of wiring more than 8 conductors per cable may be awkward to handle. Only two appear in the illustrations here, for clarity.

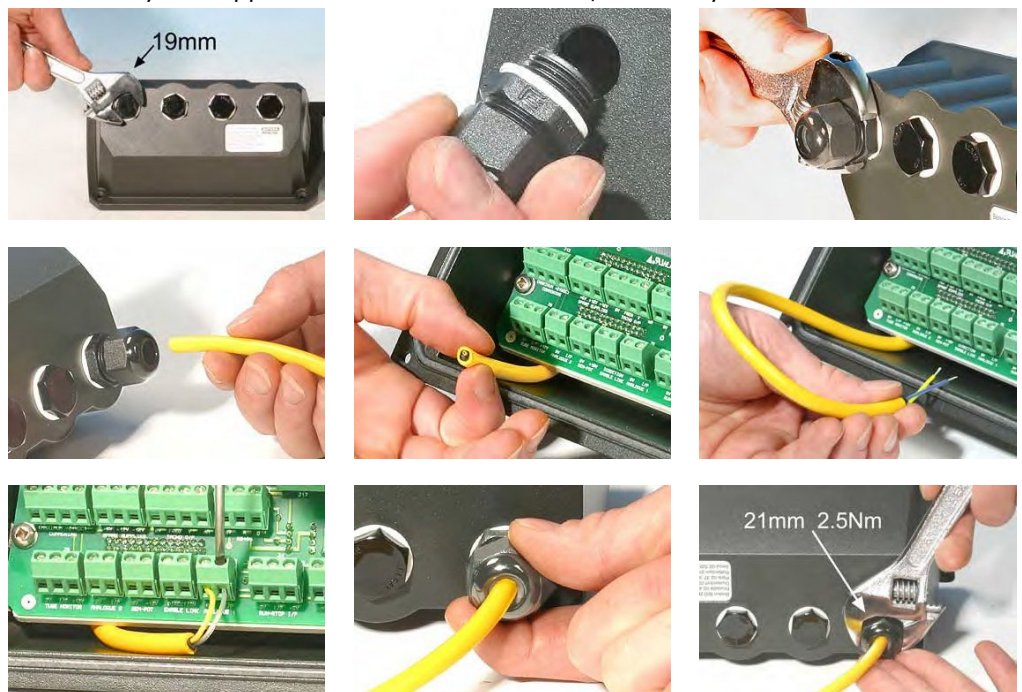

- Use a 19mm spanner to unscrew the sealing plug. Discard the nylon sealing washer.
- Screw in one of the supplied M16x1.5 cable glands in place of the plug, using the new nylon sealing washer supplied. Tighten the gland to 2.5Nm to ensure a seal, using a 21mm spanner. If a different gland is used, it must be watertight to IP66.
- Loosen the gland cap (do not remove it) and pass the cable in through the gland. When it has passed through the gland, continue to push the cable through.
- The inside of the module is shaped to guide the cable past the printed circuit board inside. Continued pushing will feed in enough cable to grip inside the module with the fingers.
- Pull through sufficient cable to reach the connectors required. Leave a little slack.
- Strip the outer sheath as necessary and remove 5mm of insulation from the conductors. No tinning or ferrule is required. Note: If very stiff or large-diameter cable is used, it may be convenient to strip the outer sheath before passing

the cable's conductors through the gland. However, to ensure a seal, cable with an undamaged sheath must be present within the gland when it is tightened.

- Twist a suitable length of the cable screen. Loosen one of the pcb retaining screws and wind the shielding round it. Secure the screen by refastening the screw. Alternatively, secure the cable screen to the adjacent spade connection (where fitted).
- Push the bared conductor into the square hole in the connector. When the conductor is fully in, tighten the retaining screw to hold it in place.
- When all conductors are in position, use a 21mm spanner to tighten the gland cap to 2.5Nm to ensure a seal. Alternatively, tighten the gland by hand until it is finger-tight and use a spanner to tighten it further by one-half a turn.

Do not strap the control and mains power cables together.

620N watertight module pcb connectors:

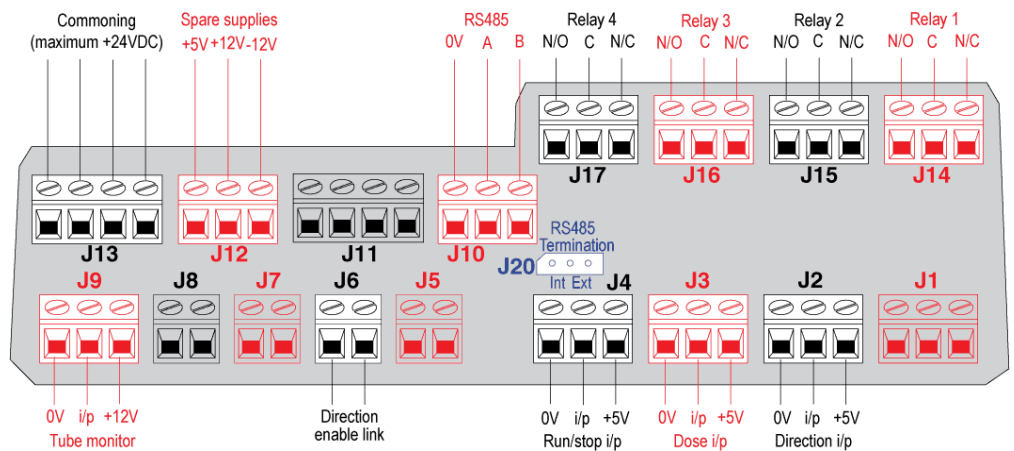

Never apply mains power to the terminals within the 620N module. Apply the correct signals to the terminals shown below. Limit signals to the maximum values shown. Do not apply voltage across other terminals. Permanent damage, not covered by warranty, may result. The maximum rating on the relay contacts of this pump is 30V DC; maximum load 30W. Note: Also suitable for low power: ie, 1mA at 5VDC minimum.

RS485 settings

Baud	Set in Setup, Baud. Factory default is 9600	Parity	None
Stop bits	2	Handshake	None
Data bits	8	Auto echo	On



Never apply mains voltage to the D-connectors. Apply the correct signals to the pins shown. Limit signals to the maximum values shown. Do not apply voltage across other pins. Permanent damage, not covered by warranty, may result.

Typical connections

Inputs

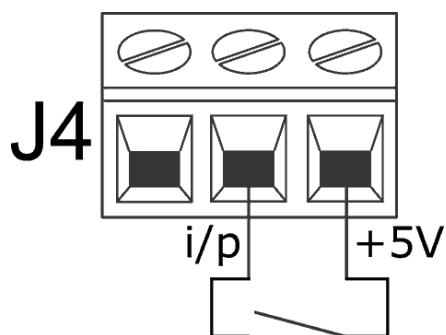

Run / stop and other change-of-state commands can be switched, above, or accomplished by a logic signal, below

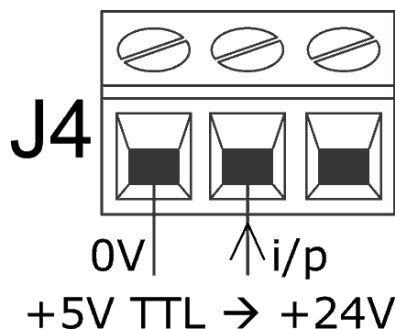

Outputs

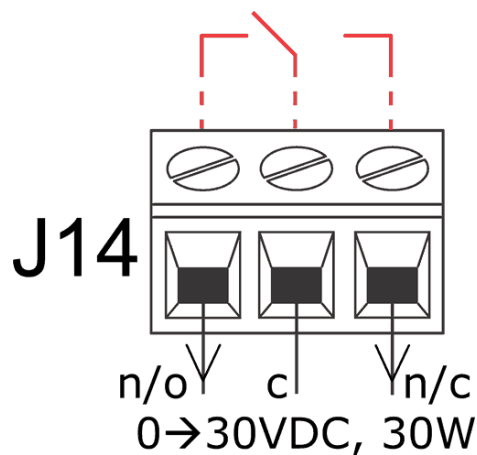

Relay output 1, showing (red) its internal configuration

Important: general instructions for remote control inputs

All remote control inputs can be wired in two ways:

Logic

A logic voltage between 5V TTL and 24V industrial logic may be wired to the input. The pump is configured to operate without modification anywhere in this range. Any of the 0V terminals - though preferably the 0V terminal associated with the desired input - is connected to the control device's 0V to make the circuit. Low is equivalent to 0V. High is equivalent to 5V-24V.

Switch

A remote switch may be connected between the input and any positive voltage supply from the pump - though preferably the associated supply terminal. Do not use the 10V supply from the Rem-pot connector, however.

20.3 Run/stop input

Remote run/stop: connect a remote switch between the **i/p** terminal and the **+5V** terminal of the Run/stop i/p connector (J4). Alternatively a logic input may be applied to the **i/p** terminal, ground to the **0V** terminal. High input stops the pump, low input runs the pump. With no connection or with the switch open, the pump will default to running. To change or set the sense of the run/stop input, see 19.11 Remote stop in the Setup menu.

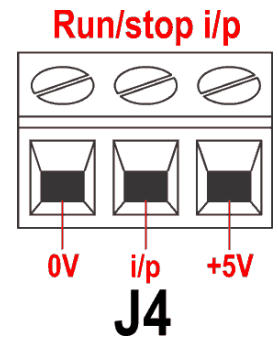

20.4 Direction input

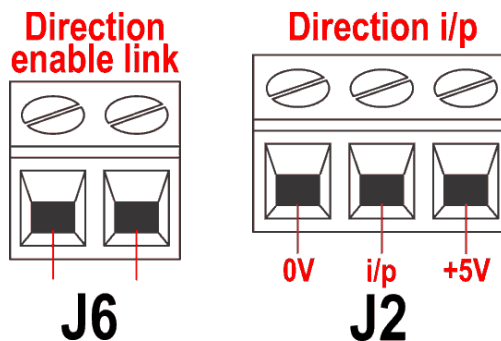

To enable remote direction control and disable the **DIRECTION (SHIFT, 1)** key on the keypad, link the terminals of the Direction enable link connector (J6). **Important: Apply no voltage whatever to the Direction enable link.** Connect a remote switch between the **+5V** terminal and the **i/p** terminal of the Direction i/p connector (J2). Open switch for clockwise rotation, closed switch for counter-clockwise rotation. Alternatively a logic signal may be applied to the **i/p** terminal and the **0V** terminal of the Direction i/p connector (J2). Low input for clockwise rotation, high input for counter-clockwise rotation. With no connection the pump defaults to clockwise rotation.

20.5 Dose input

Connect a momentary contact switch such as a footswitch or a handswitch between the **5V** terminal and the **i/p** terminal of the Dose i/p connector (J3). Close the switch to begin a dose. This input is software-debounced and functions in a similar way to the other remote inputs, such as with 5V to 24V logic as shown above, using the **i/p** terminal and the **0V** terminal.

Note: This input is software-debounced, so the signal can be either momentary or maintained during the dose. If maintained, the signal must be removed before the next dose.

Note: Connect only one pump through one switch. If several pumps must be started at once, use multiple poles and isolate each circuit.

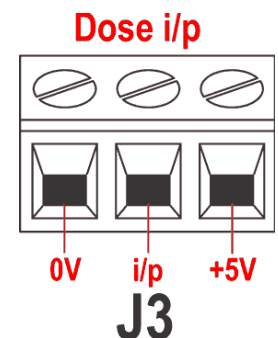

20.6 Leak detection input

Connect a remote leak-detection device between the **+12V** terminal and the **i/p** terminal on the Tube monitor connector (J9). Closed circuit indicates a leak. Alternatively a logic input may be applied to the **i/p** terminal, ground to the **0V** terminal. High input indicates a leak. Connect the cable of a Watson-Marlow Tube monitor leak detector as follows:

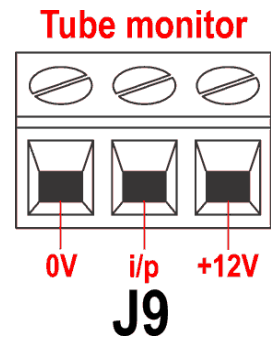

Tube monitor wire colour	620N module
Blue	J9 0V terminal
Yellow	J9 i/p terminal
Red	J9 +12V terminal
Terminate the screen in the 620N module with a 360° EMC gland if required. See 22.2 Wiring up.	

Note: Use only Watson-Marlow Ltd 620 series tube monitors.

Important: pump status outputs

Outputs 1-4 are available as single-pole change-over relay contacts: Relay 1, 2, 3 and 4. Connect to the normally open or normally closed contacts of the relay as required and configure the pump's software accordingly. See Outputs.

Note: The maximum rating on the relay contacts of this pump is 30V DC; maximum load 30W.

Note: Also suitable for low power: ie, 1mA at 5VDC minimum..

20.7 Outputs 1, 2, 3, 4

Note: Relay 1 (J14) is represented here. Relay 2, Relay 3 and Relay 4 (J15, J16 and J17) function identically.

Connect your output device to the **c** (common) terminal of your chosen relay connector and either the **n/c** terminal or the **n/o** terminal (normally closed or normally open) as required. Configure the pump's software accordingly. See 19.10 Outputs.

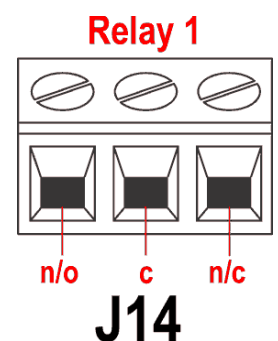

By default, Relay 1 is configured to indicate Run/Stop status; Relay 2 is configured to indicate Direction status; Relay 3 is configured to indicate Auto/man status; Relay 4 is configured to indicate General alarm status. See 12 Switching the pump on for the first time.

20.8 Supply voltages

An appropriate voltage supply is available where required on each connector. In addition, supplies may be drawn from the Spare supplies connector (J12).

In the table below, "Max load" is the maximum total load on each supply, irrespective of the number of connections.

DC Voltage	Max load	Typical use
+5V	10mA	Voltage supply for inputs using remote switch. Possible voltage supply for outputs if only 5V is required.
+12V	10mA	Possible voltage supply for inputs using remote switch. Possible voltage supply for outputs. Voltage supply for Flexicon Tube Monitor leak detector. Part voltage supply (-12V also needed) for the Flexicon proximity switch.
-12V	10mA	Part voltage supply (+12V also needed) for the Flexicon proximity switch.

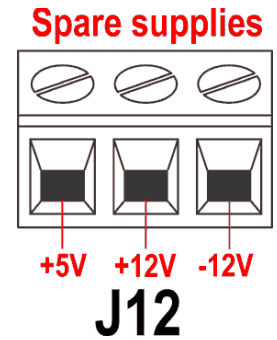

Note: All DC supplies are stabilised.

20.9 RS485 input

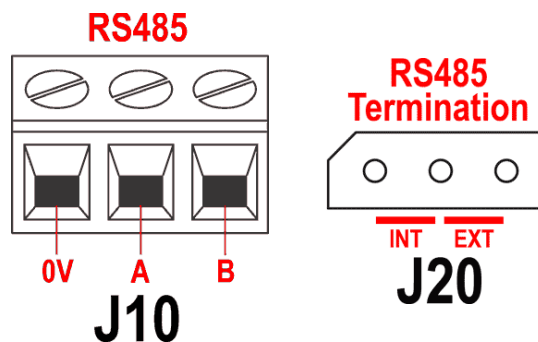

Connect your network link to J10 using a screened twisted pair: A to A, B to B, screen to 0V. Ensure that the pump is configured to operate under Network control. More than one pump may be controlled with the same RS485 signal: connect all pumps in parallel. See 22 Network control and operation.

The shorting link at J20 must be correctly positioned to allow RS485 control to function properly. Fit the shorting link of a single pump or of the last pump on a network line in the position marked INT on the three-pin header; fit the shorting link of all other pumps on the network line in the position marked EXT on the three-pin header.

21 Automatic control wiring without the 620N module

Interfacing the pump with other devices is by means of three D-connectors at the rear of the pump. There are two 25-way D-connectors. The top one is male, the bottom one is female. Mating female and male connectors, screened for EMC compatibility, must be conventionally soldered to screened control cables.

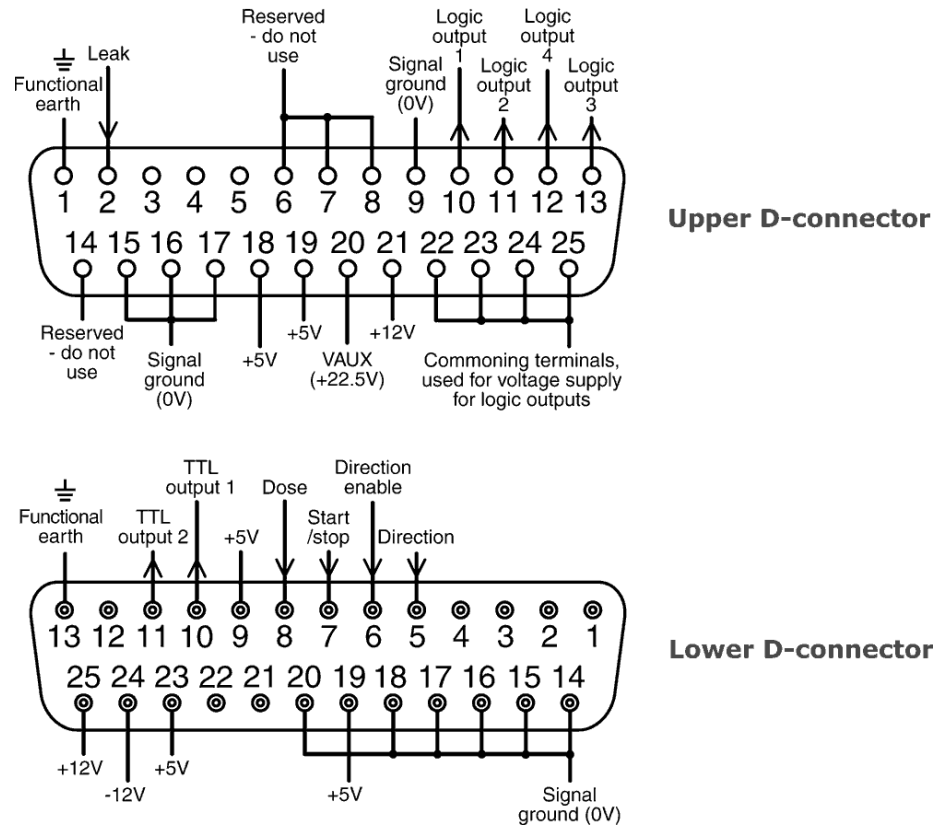

Recommended control cable: 7 strands 0.2mm, 24AWG, screened, circular, up to 25-core. The cable screen should be earthed either through the functional earth pin on the D-connector (pin 1 on the upper (male) 25-way D-connector) (pin 13 on the lower (female) 25-way D-connector), or through the metalwork of the socket or plug.

This pump passes all EMC compatibility requirements with up to 25m (82ft) of the cable type specified above. Beyond this distance it is the user's responsibility to ensure the pump's safe and reliable operation under remote and automatic control.

Do not strap the control and mains power cables together.

The 0V lines on this pump are mains transformer-isolated from ground (floating ground). It can be connected to isolated 0V or grounded 0V interfaces. The TTL (transistor transistor logic) outputs 1 and 2 used here are composed of two states: nominally 0V and 5V; but in practice <0.4V (<16mA) and 2.4-5V (<0.4mA). They are not suitable for driving relays. If a relay is to be driven by the TTL signal, it must be done as described under Logic output 1-4, below.

RS232 control

RS232 network control is available via a 9-pin D-connector wired as below.

RS232 is the mode which allows the pump to be controlled by computers and process controllers. It can control every function of the pump, and pass data back to the controller for closed loop operation. Up to 16 pumps can be individually controlled.

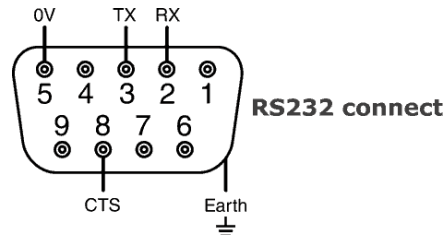

Recommended control cable: 7 strands 0.2mm, 24AWG, screened, circular, up to 4-core. The cable screen should be earthed through the metalwork of the shell.

This pump passes all EMC compatibility requirements with up to 3m (10ft) of the cable type specified above. Beyond this distance it is the user's responsibility to ensure the pump's safe and reliable operation under remote and automatic control.

The 0V lines on this pump are mains transformer-isolated from ground (floating ground).

Basic RS232 cabling

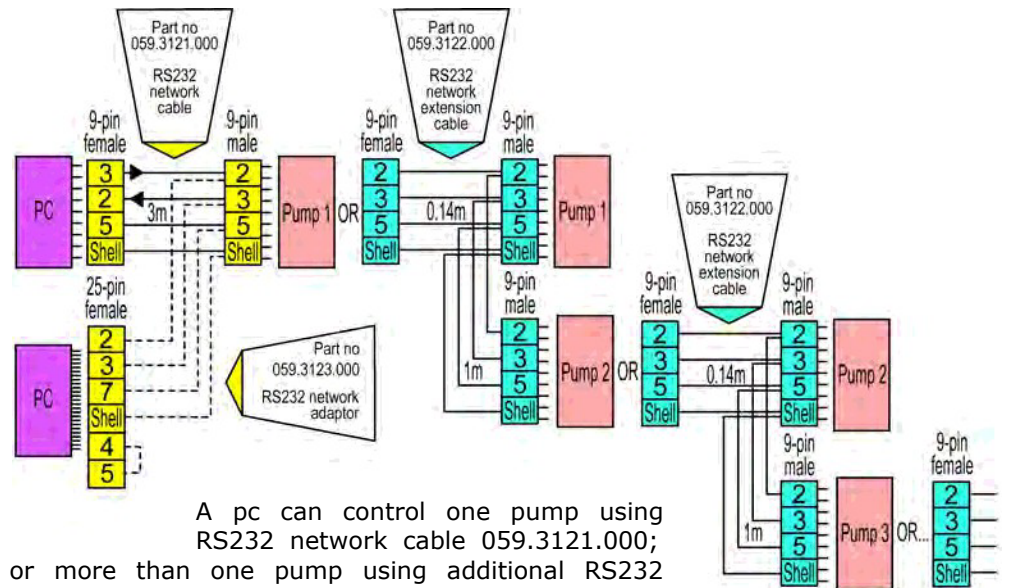

A pc can control one pump using RS232 network cable 059.3121.000; or more than one pump using additional RS232 network extension cables 059.3122.000, up to a maximum of 16 pumps. If a connection must be made to a pc fitted with a 25-pin serial outlet, use RS232 network adaptor 059.3123.000, shown, dotted, left, instead of 059.3121.000.

RS232 settings

Baud	Set in Setup, Baud. Factory default is 9600	Parity	None
Stop bits	2	Handshake	None
Data bits	8	Auto echo	On

Pin	Function	Pin	Function
1	-	6	-
2	RX (receive data)	7	-
3	TX (transmit data)	8	CTS (clear to send. Active = low)
4	-	9	-
5	0V	Shell	

Note: The CTS connection to pin 8 is optional, for use when error conditions are required.



Never apply mains voltage to the D-connectors. Apply the correct signals to the pins shown. Limit signals to the maximum values shown. Do not apply voltage across other pins. Permanent damage, not covered by warranty, may result.

Important: general instructions for remote control inputs

All remote control inputs can be wired in two ways:

Logic

A logic voltage between 5V TTL and 24V industrial logic may be wired to the input pin. The pump is configured to operate without modification anywhere in this range. Any of the 0V pins is connected to the control device's 0V to make the circuit. One 0V pin is identified in the wiring diagram, but any may be used. Low is equivalent to 0V. High is equivalent to 5V–24V.

Switch

A remote switch may be connected between the input pin and any positive voltage supply from the pump. One 5V supply pin is identified in the wiring diagram but there are several which will do, either 5V or other positive voltage. However, do not use pin 21 on the lower D-connector or pin 20 on the upper D-connector.

21.1 Run/stop input

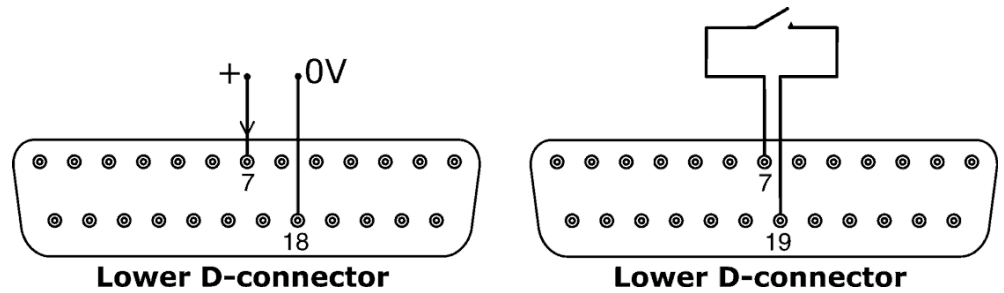

Remote run/stop: connect a remote switch between pins 7 and 19 of the lower D-connector. Alternatively a logic input may be applied to pin 7 of the lower D-connector, ground to pin 18. High input stops the pump, low input runs the pump. With no connection or with the switch open, the pump will default to running. To change or set the sense of the run/stop input, see 19.11 Remote stop in the Setup menu.

21.2 Direction input

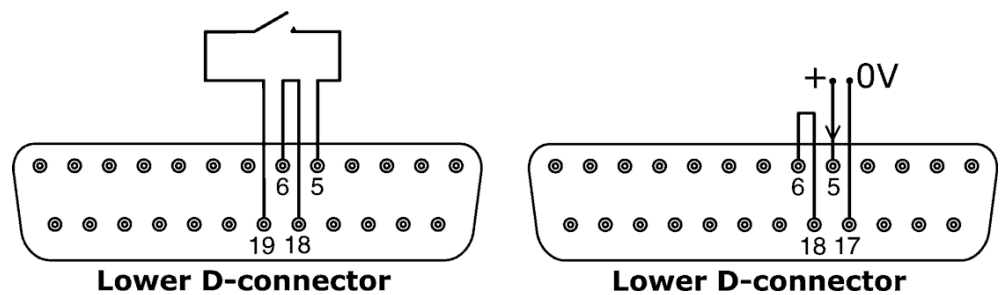

To enable remote direction control and disable the **DIRECTION (SHIFT, 1)** key on the keypad, link pins 6 and 18 of the lower D-connector. Connect a remote switch between pins 5 and 19 of the lower D-connector. Open switch for clockwise rotation, closed switch for counter-clockwise rotation. Alternatively a logic signal may be applied to pin 5 of the lower D-connector, ground to pin 17. Low input for clockwise rotation, high input for counter-clockwise rotation. With no connection the pump defaults to clockwise rotation.

21.3 Dose input

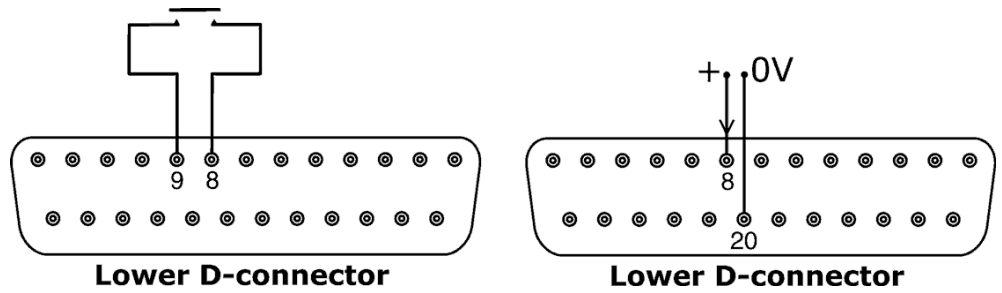

Connect a momentary contact switch such as a footswitch or a handswitch between pins 8 and 9 of the lower D-connector. Close the switch to begin a dose. This input is software-debounced and functions in a similar way to the other remote inputs, such as with 5V to 24V logic as shown above, using pin 8 as the input and pin 20 as the 0V (lower D-connector).

Note: This input is software-debounced, so the signal can be either momentary or maintained during the dose. If maintained, the signal must be removed before the next dose.

Note: Connect only one pump through one switch. If several pumps must be started at once, use multiple poles and isolate each circuit.

21.4 Leak detection input

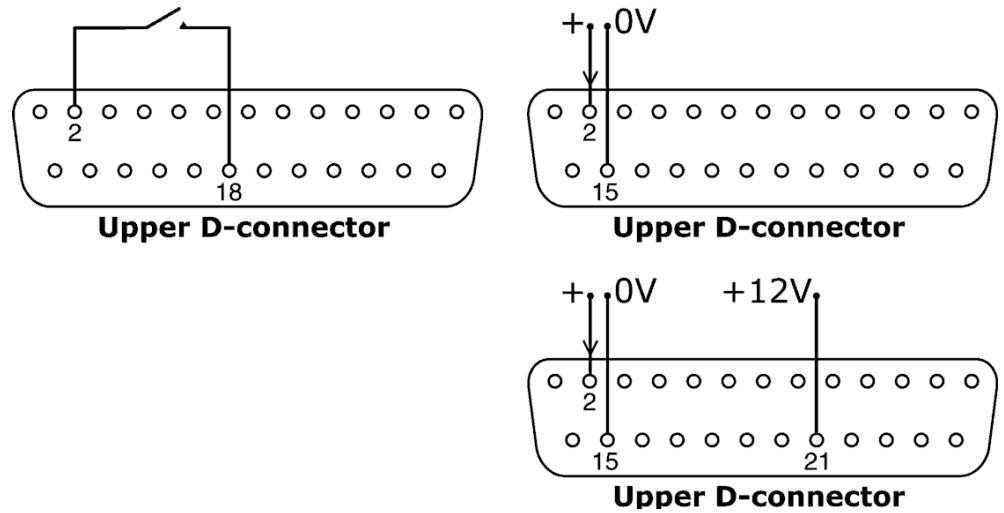

Connect a remote leak-detection device between pins 2 and 18 of the upper D-connector. Closed circuit indicates a leak. Alternatively a logic input may be applied to pin 2 of the upper D-connector, ground to pin 15. High input indicates a leak. Connect a Watson-Marlow leak detector in the same way, drawing 12V to power it from pin 21 of the upper D-connector.

Connect the cable of a Watson-Marlow Tube monitor leak detector as follows:

Tube monitor wire colour	Pin number upper D-connector
Blue	15
Yellow	2
Red	21

Note: Use only a Watson-Marlow 620 series tube monitor.

21.5 Pump status outputs

Important: pump status outputs

All four outputs can be configured in software to output a range of parameters: see Outputs under Setup.

Outputs 1 and 2 are available simultaneously from the upper and lower D-connectors. The outputs from the lower D-connector operate at 5V TTL only.

All four outputs available from the upper D-connector are open-collector.

By applying a positive voltage to a maximum of 24V to pin 22 of the upper D-connector, all the outputs from this plug are at that voltage: pin 22 is commoned with pins 23, 24 and 25. Care must be taken to ensure that the supply voltage has sufficient capability to drive all the loads applied to all outputs used. **Important: The total load of the four logic outputs must not exceed 50mA.**

21.5.1 Logic output 1

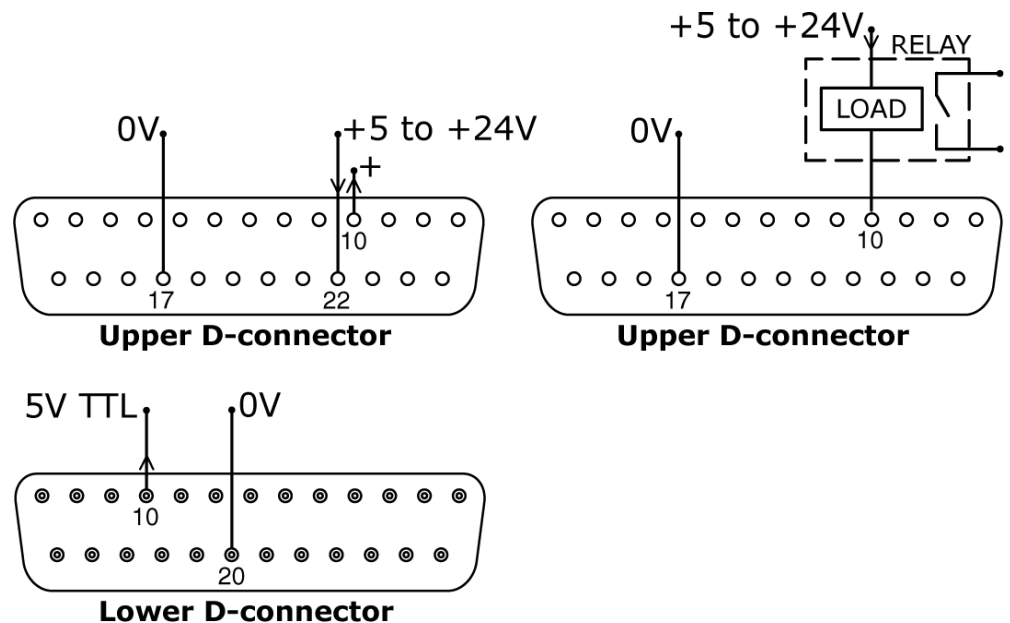

Output 1 is taken from pin 10 of the upper D-connector, depending on the logic state of the function assigned to Output 1. Alternatively, a load such as a relay coil may be connected to pin 10, ground to pin 17. Current will flow through the circuit depending on the logic state of the function assigned to Output 1. Do not connect to any device requiring more than 50mA.

Additionally, output 1 is available as a 5V TTL logic signal on pin 10 of the lower D-connector. It will change state corresponding to the logic state of the function assigned to Output 1. Do not connect to any device requiring more than 1 TTL load.

By default, output 1 is configured to indicate Run/Stop status. See 12 Switching the pump on for the first time.

21.5.2 Logic output 2

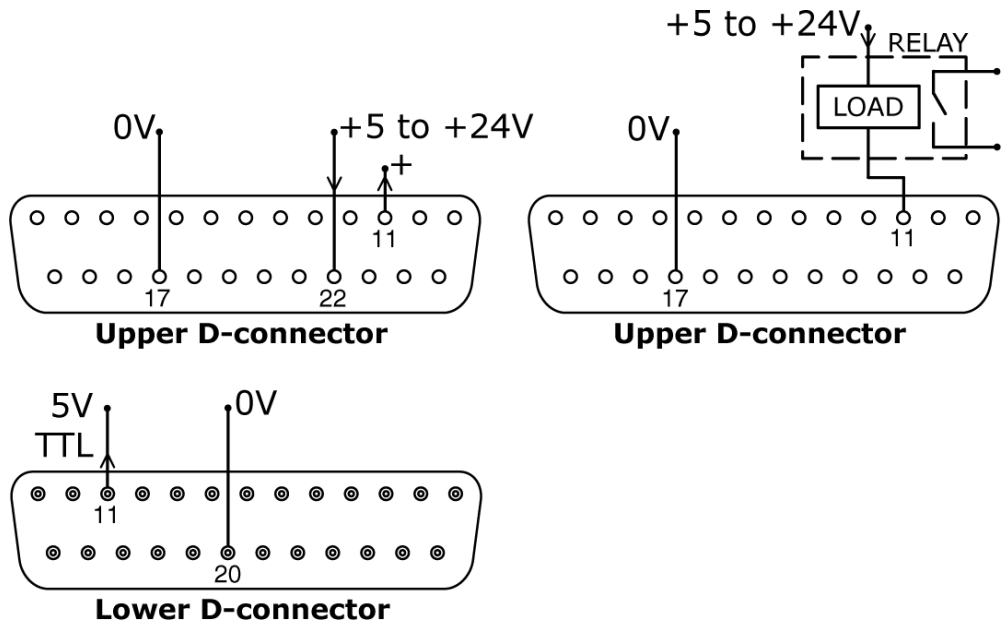

Output 2 is taken from pin 11 of the upper D-connector, depending on the logic state of the function assigned to Output 2. Alternatively, a load such as a relay coil may be connected to pin 11, ground to pin 17. Current will flow through the circuit depending on the logic state of the function assigned to Output 2. Do not connect to any device requiring more than 50mA.

Additionally, output 2 is available as a 5V TTL logic signal on pin 11 of the lower D-connector. It will change state corresponding to the logic state of the function assigned to Output 2. Do not connect to any device requiring more than 1 TTL load.

By default, output 2 is configured to indicate Direction status. See 12 Switching the pump on for the first time.

21.5.3 Logic output 3

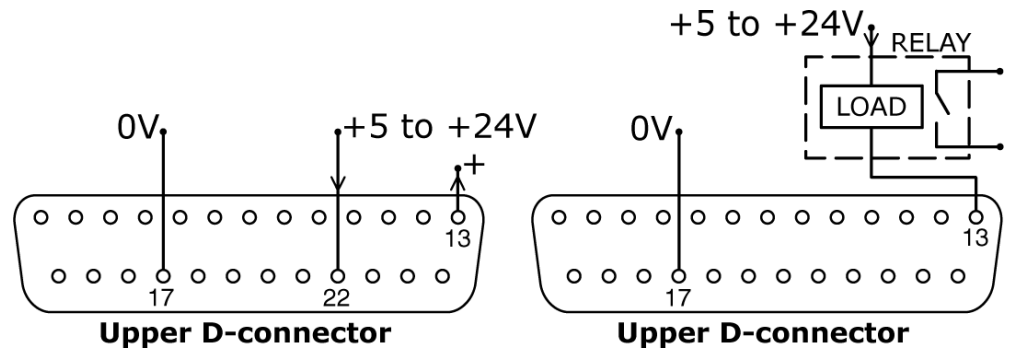

Output 3 is taken from pin 13 of the upper D-connector, depending on the logic state of the function assigned to Output 3. Alternatively, a load such as a relay coil may be connected to pin 13, ground to pin 17. Current will flow through the circuit depending on the logic state of the function assigned to Output 3. Do not connect to any device requiring more than 50mA.

By default, output 3 is configured to indicate Auto/Man status. See 12 Switching the pump on for the first time.

21.5.4 Logic output 4

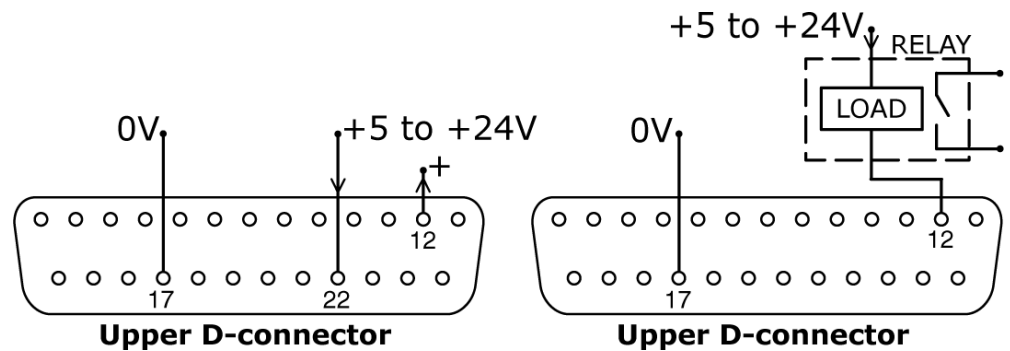

Output 4 is taken from pin 12 of the upper D-connector, depending on the logic state of the function assigned to Output 4. Alternatively, a load such as a relay coil may be connected to pin 12, ground to pin 17. Current will flow through the circuit depending on the logic state of the function assigned to Output 4. Do not connect to any device requiring more than 50mA.

By default, output 4 is configured to indicate General alarm status. See 12 Switching the pump on for the first time.

21.6 Supply voltages

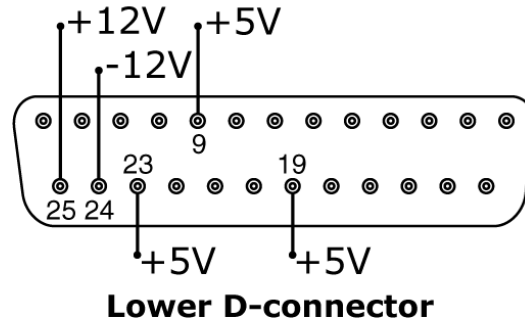
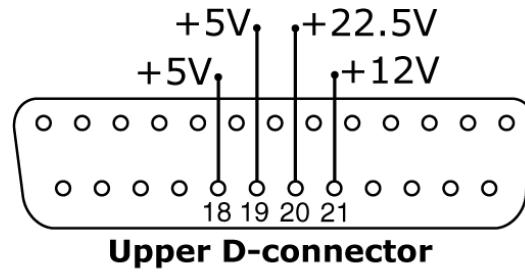

In the table below, "Max load" is the maximum total load on each supply irrespective of the number of connections.

DC Voltage	Max load	Lower D	Upper D	Typical use
+5V	10mA	9, 19, 23	18, 19	Voltage supply for inputs using remote switch. Possible voltage supply for outputs if only 5V is required. Pin 9 is specifically used for footswitch / handswitch operation
+12V	10mA	25	21	Possible voltage supply for inputs using remote switch. Possible voltage supply for outputs. Voltage supply for Flexicon Tube Monitor leak detector. Part voltage supply (-12V also needed) for the Flexicon proximity switch
-12V	10mA	24	-	Part voltage supply (+12V also needed) for the Flexicon proximity switch
+22.5V	-	-	20	Voltage supply for the 620N wash-down module. Do not use

Note: All DC supplies are stabilised except the +22.5V.

22 Network control and operation

Check that the pump is ready to run before selecting network operation. Remote control signals may start the pump without warning.

How to get into network operation

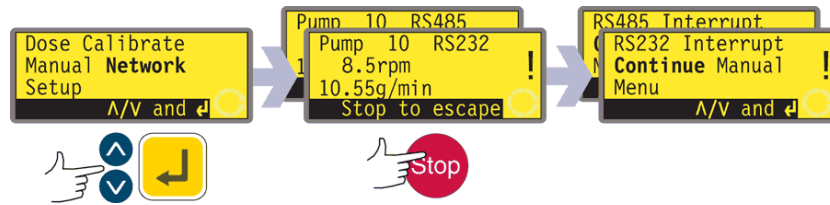

- Use the **UP** and **DOWN** keys to select **Network** from the Main menu. Press **ENTER** to confirm.
- The pump enters Network (RS232 or RS485) mode and is under network control.
- Auto-restart is switched on and the pump displays the (!) icon.
- The only keys active are **STOP** and **SHIFT, 9 (INFO)**.
- Remote stop, Net/man, Direction enable and Direction inputs are inactive. Leak and Dose inputs are active. See 24.1 Error codes.
- All pump status outputs are active.

How to get out of network operation

- Pressing the **STOP** key displays three options: **Continue**, **Manual** and **Menu**. Use the **UP** and **DOWN** keys to choose and press **ENTER** to confirm.
- Selecting **Continue** returns the pump to network (RS232 or RS485) mode.
- Selecting **Manual** sets the pump to manual operation and retains the set speed and run status from its previous operation in Network mode. See 14 Manual operation.
- Selecting **Menu** displays the Main menu (see 15 Main menu).

Emergency stop

- In an emergency press the **STOP** key. The pump stops and displays an interruption screen, from which select **Continue** to return to network control, **Manual** to set the pump to manual control (see 14 Manual operation), or **Menu** to display the main menu (see Main menu). Use the **UP** and **DOWN** keys to choose and press **ENTER** to confirm.

22.1 RS232 and RS485 command strings

Command	Parameters	Meaning
nCA	-	Clear LCD display
nCH	-	Home the cursor
nDO	xxxxxxxxx<,yyyyy>	Set and run one dose of xxxxxxxxxx tacho pulses, with optional drip of yyyyy (maximum 11,000) tacho pulses. See note 1
nTC	-	Clear the cumulative tachometer count
nSP	xxx.x	Set speed to xxx.x rpm
nSI	-	Increment speed by 1rpm
nSD	-	Decrement speed by 1rpm
nGO	-	Start running
nST	-	Stop running
nRC	-	Change direction
nRR	-	Set direction to clockwise
nRL	-	Set direction to counter-clockwise
nRS	-	Return status. See note 2
nRT	-	Return the cumulative tachometer count
nW	[line 1]~[line 2]~[line 3]~[line 4]@	Display text on 1 to 4 lines with ~ as the line delimiter. Terminated by the @ character. See note 3
nZY	-	Return 0 for stopped or 1 for running
nPD	a,b,c,d,e,f,g,h,i,j	Program dose. See note 5
nPD?	0Di,*#,a,b,c,d,e,f,g,h,i,j	Query dose parameters. See note 9
nPA	-	Query all dose program parameters. See note 8
nCC	-	Clear the batch count
nSC	-	Responds with ccccc ! This is the number of complete doses which have been started via the RP command, delivered since the last PD command
nRP	-	Runs the programmed dose and increments the batch count. See note 9
nLP	xxxxxxxx	This allows a saved program to be recalled from NVRAM. The program name is a string of 8 characters precisely. Unused positions must be padded with spaces (ASCII 32)
nCB	xx.xxx	Parameter is a fixed point number representing the new calibration in ml/rev
nD?	-	Reports last full dose dispensed. See note 11
nCF	#####	Calibration-on-the-fly new dose value, subject to the $\pm 25\%$ rule. See note 12

Note 1: The correlation between tachometer pulses and motor rotation is fixed and provides a measurable and absolute way of monitoring the number of revolutions of the gearbox output shaft - 10,982 pulses per revolution. This in turn allows the count to be equated to the amount of material dispensed - assuming that the pumphead type and tube size are known.

Note 2: The status is returned to the sender in the following format: [pump type] [ml/rev] [pumphead] [tube size] [speed] [CW/CCW] P/N [pump number] [tacho count] [0/1 (stopped/running)] !
For example: 620Du 15.84 620R 9.6MM 220.0 CW P/N 1 123456789 1 !

Note 3: If the pump speed is changed subsequently, the pump must display the screen shown here (example figures only) for 4 seconds before reverting to the custom display. 1 to 4 lines of text can be written with ~ as the line delimiter and @ as the message end. i.e., 1W620Du@ and 1W620Du~@ are both valid commands.

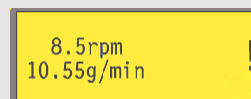

Note 4: 'n' can be any number from 1 to 16 inclusive, and by exception the # symbol can be used as an all-drives command; but not with the RS, RT or ZY commands, as the results would be indeterminate.

Note 5: The dose parameters are all required, except that SG is only required for dosing by mass, and are variable in length, separated by commas. Missing or illegal characters will cause the command to be aborted and an error message generated on the display. See the table right for an explanation of the expected parameters:

Parameter	Range	Meaning
a	1-9999	Number of doses
b	[A C]	Rotation: counter-clockwise or clockwise
c	0-999	Interval in seconds: eg 1.0
d	0001-3500	Pump speed: tenths of an rpm
e	0-5	Start ramp: scale factor
f	0-5	End ramp: scale factor
g	0.0-1.0	Drip: rev
h	0.001-9999	Dose size: eg 10.00
i	[l m u g kg floz pts gals oz lb]	Dose unit: litres, ml, µl, grams, kg, fluid ounces, pints, gallons, ounces, pounds
j	0.01-15	Specific gravity: eg 1.00

Note 6: No response will be given and the PD? command should be issued to ensure that the command has been accepted. These values will become the current dispense program, as set up in dose mode, overwriting the current values. This command resets the batch count.

Note 7: This command elicits the response 620Di,*,#,a,b,c,d,e,f,g,h,i,j ! where the * is the head type and the # is the calibration value in ml/rev. The remaining parameters are defined above.

Note 8: This invokes the response P/P/P/P/P/P/P/P,*,#,a,b,c,d,e,f,g,h,i,j ! for each dose program saved on pump id = n. The format of this string is the 8-character program name (padded with spaces), followed by the normal dose query parameters, without the pump type identifier.

Note 9: The run dose command allows a dose program, set using PD or DO, to be initiated. It also allows the current dispense program, set up in dose mode via the keypad, to be initiated. Normal dose status messages will not be produced; instead a single 'Start' message will be sent back in response, with the following format: P/N [id] [date] [time] Program Started ! For example: P/N 01 08.12.00 11.28.00 Program Started !
On completion of a single dose, the batch count will be incremented by one.

Note 10: If a change speed command is issued while the dose is active the change will not be effected until the current dose is completed.

Note 11: The dose dispensed is a value in the form ***** !
For example: 30.45 !

Note 12: If a value is outside the $\pm 25\%$ rule, an error message is sent back in a string terminated by !. It uses the existing calibration value.

Di

23 Connecting a computer

A computer may be connected to the pump using a nine-pin D-connector wired as shown under Network control and operation. See 21 Automatic control wiring without the 620N module.

Note: Computer output is not available when the pump is under network control.

24 Troubleshooting

If the pump display remains blank when the pump is on, make the following checks:

- Check the position of the voltage selector switch at the rear of the pump.
- Check the mains power switch at the rear of the pump.
- Check that mains power is available to the pump.
- Check the fuse in the fuseholder in the centre of the switchplate at the rear of the pump.
- Check the fuse in the mains power plug if one is present.

If the pump runs but there is little or no flow, make the following checks:

- Check that the tube and rotor are in the pumphead.
- Check that fluid is supplied to the pump.
- Check that the tube is not split or burst.
- Check for any kinks or blockages in the lines.
- Check that any valves in the lines are open.
- Check that the correct wall-thickness tube is being used.
- Check direction of rotation.
- Check that the rotor is not slipping on the drive shaft.

If trouble persists, technical assistance for this product is available from your distributor or Watson-Marlow Limited, Falmouth TR11 4RU, United Kingdom.

24.1 Error codes

If an internal error occurs, a flashing error screen is displayed. **Note: Signal out of range, Over signal, No signal and Leak detected** error screens report the nature of an external signal. They do not flash.

Error condition	Suggested action
RAM write error	Attempt to reset by switching power OFF / ON. Or seek support
RAM corruption	Attempt to reset by switching power OFF / ON. Or seek support
OTP ROM error / corruption	Attempt to reset by switching power OFF / ON. Or seek support
OTP ROM read error	Attempt to reset by switching power OFF / ON. Or seek support
Unknown pump type	Check the interface card and cables. Attempt to reset by switching power OFF / ON. Or seek support
Display failure	Seek support
Wrong key-press	Attempt key-press again. Attempt to reset by switching OFF / ON
Motor stalled	Stop pump immediately. Check pumphead and tube. Power OFF/ON may reset. Or seek support
Tacho fault	Stop pump immediately. Power OFF/ON may reset. Or seek support
Speed error	Stop pump immediately. Power OFF/ON may reset. Or seek support
Over current	Stop pump immediately. Check system. Power OFF/ON may reset. Or seek support
Over voltage	Stop pump immediately. Check mains voltage selector switch. Check supply. Power OFF/ON may reset. Or seek support
Under voltage	Stop pump immediately. Check mains voltage selector switch. Check supply. ON/OFF may reset. Or seek support
Watchdog error	Attempt to reset by switching power OFF / ON. Or seek support
Over temperature	Stop pump immediately. Turn OFF. Seek support
Signal out of range	Check analogue control signal range. Trim signal as required. Or seek support
Over signal	Reduce the analogue control signal
No signal	Connect analogue control signal or return to manual control
Leak detected. Check and reset	Remove the cause of any leak. The STOP key resets
Unrecognised key-press	Attempt key-press again. Attempt to reset by switching power OFF/ON. Or seek support
Work overload	Turn OFF. Check power supply. Check pumphead and tubing. Wait 30 minutes. Power ON may reset. Or seek support
Network not detected	Turn OFF. Check network and connections. Or seek support
RS232/485 fault	Turn OFF. Check network and connections. Or seek support
RS232/485 lost	Turn OFF. Check network and connections. Or seek support
General error condition	Turn OFF .Seek support

DiN, Di

25 Drive maintenance

There are no user serviceable parts inside the pump. The unit should be returned to Watson-Marlow or its appointed agents or distributors for service.

DiN, Di

26 Drive spares

Replaceable main fuse, type T 5A H 250V: FS0043

Foot: MR3002M x5

DiN, Di

Pumphead use is independent of drive ingress protection. No reference to ingress protection rating or drive model (620DiN or 620Di) is made throughout the pumphead sections of this manual.

27 620RE MarkII, 620RE4 MarkII and 620R MarkII pumpheads

Note: MarkII pumpheads differ from MarkI pumpheads as follows: they have a new guard-switching arrangement which is not compatible with 623/624 drives. Similarly, older guards are incompatible with 620 drives. Elsewhere in this manual, the term "MarkII" is omitted.

27.1 620RE, 620RE4 and 620R key safety information



Before opening the pumphead guard please ensure that the following safety directions are followed.

- Ensure that the pump is isolated from mains voltage.
- Ensure that there is no pressure in the pipeline.
- If a tube failure has occurred, ensure that any product in the pumphead has been allowed to drain through the controlled waste to a suitable drain.
- Ensure that protective clothing and eye protection are worn if hazardous products are being pumped.

27.2 620RE, 620RE4 and 620R safe-guarding

- Primary safety on 620 series pumps is provided by the tool-lockable pumphead guard. Secondary (backup) protection is provided in the form of an electrical guard switch which stops the pump if the pumphead guard is opened. The electrical guard switch on cased pumps should never be used as primary protection. Always disconnect the mains power supply to the pump before opening the pumphead guard.

27.3 620RE, 620RE4 and 620R pumping conditions

Pressure and viscosity

- All pressure values in this operating instruction, from which performance and life figures have been calculated, relate to peak pipeline pressures.
- Although rated to 4 bar peak pressure, this pump will generate in excess of 4 bar peak pressure if pipeline restrictions are in place. In instances where it is critical that a peak pressure of 4 bar is not exceeded, pressure relief valves should be installed in the pipeline.
- For pumping duties of 2-4 bar pressure, fit hard Marprene/Bioprene or standard STA-PURE Series PFL or STA-PURE Series PCS tube elements. "M" or "P" in the tube element's product order code denotes suitability for higher pressure use.
- For pumping duties of 0-2 bar pressure, use standard hardness elements or the standard range of continuous peristaltic pump tubing.
- Viscosity handling is maximised by using hard Marprene/Bioprene, STA-PURE Series PFL or STA-PURE Series PCS tube elements in the pumphead.
- Ensure that there is always a minimum of one metre of smooth bore flexible tubing connected to the discharge port of the pumphead. This will help minimise any impulse losses and pulsation in the pipeline. This is especially important with viscous fluids and rigid pipework.

27.4 620RE, 620RE4 and 620R pump installation

A correctly engineered installation will promote the best possible tube life, so please ensure that the following guidelines are followed:

- Avoid tight pipeline bends, pipe reducers and excessive lengths of smaller bore tubing than that in the pumphead, particularly in pipelines on the suction side.
- Ensure that connecting pipe work and fittings are suitably rated to handle the predicted pipeline pressure.
- If rigid pipe work comes in close proximity to the pumphead, a drop-out section of pipe work will simplify tube replacement.
- Ensure that the controlled waste blanking plug is in position if the controlled waste port is not in use. See below.
- It is advisable to use controlled waste pipe work if pumping hazardous, aggressive or abrasive fluids or products which will harden in contact with air.



- Connect waste pipe work to the waste port using the coupling adaptor supplied.
- Push out the blanking plug. Drop the threaded waste fitting into place. Secure it with the supplied locking nut. Fully tighten by hand. Ensure that there is adequate clearance underneath the pumphead. Waste pipe work should run to a suitable container or drain.
- The leak detector installation procedure is included in the leak detector kit.
- If unsure of an installation please contact your local Technical Support Office.

27.5 620RE, 620RE4 and 620R general operation



Always isolate the pump from the mains power supply before opening the guard or performing any positioning, removal or maintenance.

Opening the pumphead guard

- Unlock the guard with the 5mm Allen key provided (or a screwdriver).
- Open the guard to its full extent. This creates the maximum clearance between the tube ports and guard to remove the tubing.

Engaging/disengaging the rollers



- The extent of travel of the roller release levers is clear from pictures 2 and 3 above. Do not try and force the levers beyond their normal extent of travel as this will damage the rotor.
- To engage the rollers snap the roller release levers counter-clockwise making sure that the rollers lock out against the tubing. To disengage the rollers, snap the release levers clockwise to their disengaged position. For high pressure tubing elements or four roller pumpheads, a 5mm Allen key can be used to aid leverage when engaging/disengaging the rollers with the release levers.



Make sure that fingers are clear of the rollers and the front face of the rotor hub when using the roller release levers.

Pre-load checks

- Before loading tubing, ensure that all rollers rotate freely, that the tube ports and location grooves are clean and that if in use, the controlled waste pipe work is free of any obstructions.

Closing the pumphead guard and start-up

- Ensure that the guard seal is clean, replacing it if necessary.
- Ensure that the rollers are engaged and locked out against the tubing
- Close the guard and push it against the track until the latch engages.
- Connect suitable pipe work to the pumphead using the appropriate connectors for the tube element. See below.

27.6 620RE and 620RE4 tube element loading



Always isolate the pump from the mains power supply before opening the guard or performing any positioning, removal or maintenance.

620RE element pumpheads are factory set to accept Watson-Marlow LoadSure tube elements. Pumping performance will be adversely affected if LoadSure elements are not used.



- Open the guard using a suitable screwdriver or a 5mm Allen key. Disengage the rollers.
- Locate one of the "D"-shaped flanges into the lower port. (The "D" flange ensures that the element can only be loaded correctly).
- Wrap the tube element around the disengaged rollers of the rotor.
- Locate the second "D"-shaped flange into the upper port.
- Ensure the flat face of each "D" flange sits flush to the flange sealing face of the track.
- Engage the rollers.
- Close the guard and push it against the track until the latch engages.

Connecting LoadSure elements to supply and discharge tubes

LoadSure sanitary elements - which have white connectors - are connected to a tubing system using Tri-clamps and EPDM gaskets.



- Hold the connector end of the supply or discharge tube against the element

- connector, with an EPDM gasket between them.
- Use a Tri-clamp to engage both flanges squarely, close it and tighten.

LoadSure industrial elements - which have black connectors - are connected to a tubing system using cam-lock (cam and groove) fittings.



- Push the female fitting over the element connector.
- Pull both cam levers closed until they engage.

27.7 620R continuous tube loading



Always isolate the pump from the mains power supply before opening the guard or performing any positioning, removal or maintenance.



- 620R continuous tubing pumpheads are factory set to accept Watson-Marlow 600 series 3.2mm wall tubing. Pumping performance will be adversely affected if Watson-Marlow tubing is not used.
- Select the tube clamp set which is correct for the tubing size to be used.
- Locate the two "U"-shaped track clamp halves into the pumphead ports (The "U"- shape ensures correct loading).
- Locate the corresponding guard clamp halves which have raised "T" locating sections, into the slots on the inner guard face above and below the guard hinge. Push and slide into their locked position.
- Closing the guard will align the two halves of the clamp around the tubing.
- Disengage the rollers.
- Locate one end of the tubing into the lower port "U" clamp and hold firmly in position.
- Wrap the tubing tightly around the retracted rollers, making sure that there is no twisting through its length.
- Locate the other end of the tubing into the upper port "U" clamp.
- Hold both ends of the tubing in one hand maintaining tension around the retracted rollers.
- Engage the rollers.

- Close the guard and push it against the track until the latch engages.
- Ensure that continuous tubing is not loosely clamped at the pumphead ports.
- Ensure that when the pump is re-started all of the rollers have re-engaged. A roller which has not re-engaged will “click” continuously. No damage will occur if this happens but the roller should be re-engaged manually using the 5mm Allen key. See 24 Troubleshooting.

27.8 620RE, 620RE4 and 620R tube element or continuous tube removal



Always isolate the pump from the mains power supply before opening the guard or performing any positioning, removal or maintenance.

- Unlock the guard and disengage the rollers.
- Disconnect the tubing from the external pipeline.
- Remove the tubing from the pumphead.

27.9 620RE, 620RE4 and 620R Maintenance

Scheduled maintenance

- The stainless steel pumping rollers run on sealed bearings and do not require lubrication.
- Remove the rotor and lubricate the follower rollers and roller engaging mechanisms with a lithium-based grease. This should be carried out every six months for intermittent duties and every three months for 24 hour duties.
- If fluid is spilled inside the pumphead, flush the pumphead out with water and mild detergent as soon as possible. If specific cleaning agents are required to clean the spillage, please consult Watson-Marlow Ltd Technical Support Office before proceeding, in order to confirm chemical compatibility.
- If the rotor needs to be removed, refer to the guidelines below.

Roller adjustment

620 pumpheads have provision for adjustment to reset the roller/track gap to compensate for wear after extended service in arduous applications.

Roller/track gaps can **only** be accurately judged without tubing in the pumphead. The gap should be **4.6mm** for 3.2mm wall tubing and **5.5mm** for LoadSure elements.

If the gap is more than 0.2mm greater than these dimensions, the following may be carried out:

- Note the number on the roller arm to which the engraved line on the hexagon-headed main roller pin corresponds.
- Remove the circlip (snap-ring) and roller pin.
- Relocate the main roller pin, resetting the engraved line to one number lower. For example, if the engraved line was at “-1”, reset it to “-2” to reduce the roller/track gap.

- Ensure the roller pin is correctly seated into the roller arm thrust washer. Replace the circlip.

Rotor removal



- Remove the rotor cover by hand and the central locating bolt using a 5mm Allen key. Pull the rotor off the keyed shaft. Do not use tools to lever the rear face of the rotor away from the inner face of the track: it should come off by hand.

Track removal

- Remove the rotor as described above.
- Disconnect the waste pipework (if attached).



- Loosen the two track retaining screws using a suitable screwdriver.
- Withdraw the track fully from the gearbox.
- After removing the rotor and track, it is advisable to remove the metal key from the keyway, clean and reassemble. The key fits its keyway tightly. It may be freed by tapping gently with a screwdriver or other suitable tool.

Track re-location



- Ensure that the track is clean.
- Align the track so that the location holes are aligned with the threaded holes in the cased drive.
- Tighten the two track retaining screws using a suitable screwdriver.
- Re-connect the waste pipework (if required).

Note: The track can be fitted in two positions: with ports to the right or with ports down. The ports-down position requires that the pump is positioned at the front of the surface it stands on to provide clearance for the supply and discharge tubes.

Rotor re-location



- Before replacing the rotor, locate the key into the driveshaft keyway and apply a thin layer of grease over the shaft and key. The rotor keyway is the largest of the four slots radiating from the driveshaft socket: the top one in the first picture, above. Align the rotor keyway with the shaft key and slide the rotor into position, ensuring that a positive "stop" is achieved and ensure that the full length of the drive shaft is fitted into the rotor.
- Do not force the rotor into position. The rotor will slide into place easily if correctly aligned.
- Secure the rotor with the hexagonal locating bolt (complete with washer) to a nominal torque of 10Nm using a 5mm Allen key.
- The rotor bolt, which is impregnated with "Loctite 218" thread lock, should be subjected to a maximum of three removals/relocations before renewal. To avoid rotor bolt renewal after three removals, apply "Loctite 222" thread lock to the rotor thread before relocation. This is critical to ensure prolonged, secure location of the rotor hub to the drive shaft. **Failure to complete this action will invalidate the terms and conditions of the warranty.**
- Replace the rotor cover.

When closing the guard, check it does not make contact with the rotor. If it does, the rotor has been fitted incorrectly. Re-open the guard, remove and refit the rotor, and close the guard.

27.10 620RE, 620RE4 and 620R CIP and SIP

General

- Unlock the guard and disengage the rollers.
- Close the guard and squeeze against the track until the latch clicks.
- Observe a 1m safety area.

CIP

- LoadSure tube elements and continuous tubing can be cleaned using CIP processes.
- Ensure that the tubing material is chemically compatible with the cleaning agent that is to be used.
- If cleaning agents are spilled over the pumphead, wash down immediately.
- Ensure that controlled waste pipe work is fitted to allow safe release of cleaning agent in the event of a tube failure.

SIP

- Only STA-PURE Series PFL and STA-PURE Series PCS tube elements can be used in a steam-in-place sterilisation processes.
- For STA-PURE Series PFL and STA-PURE Series PCS requirements refer to the tubing official product datasheet.
- Monitor the process continuously.
- If a tube failure occurs, shut down the process. Do not touch the pumphead until a 20 minute cooling period has been observed.
- Ensure a 20 minute acclimatisation period is observed before running the pump following SIP.
- Ensure that controlled waste pipework is fitted to allow a safe release of steam in the event of a tube failure.
- Ensure a 1m safety zone is maintained around the pumphead during SIP cycles.

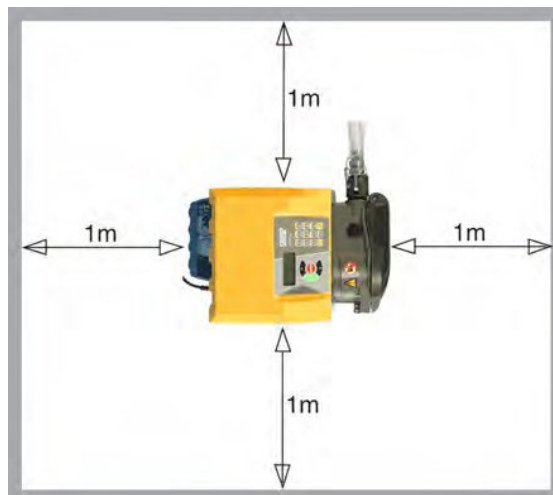



Ensure that the pumphead door is closed and locked before SIP cleaning commences.

27.11 620RE, 620RE4 and 620R pumphead spares



Number	Spare	Description
	063.4211.000	620R MarkII pumphead
	063.4231.000	620RE MarkII pumphead
	063.4431.000	620RE4 MarkII pumphead
1	069.4101.000	620RTC: continuous tubing clamp set
2	MR2052C	Oddie fastener
2	MR2053B	Clip: Oddie retainer
2	MR2054T	Oddie washer
2	SG0021	Oddie spring
2	CX0150	Oddie circlip (snap ring)
3	MRA0320A	Rotor assembly 2-roller element
3	MRA0321A	Rotor assembly 4-roller element
3	MRA0322A	Rotor assembly 2-roller continuous
4	MRA3020A	Track assembly
5	MR2028M	Controlled waste port blanking plug
6	MR2018T	Hinge pin
7	MR2002M	Guard without latch and seal
8	MR2021B	Seal - guard
9	MR2059T	Adaptor - Bodine (white polypropylene ring)
10	MA0017	Magnet
11	MR2096T	Controlled waste threaded fitting locking nut
12	MR2027T	Controlled waste threaded fitting 620R, RE, RE4
13	MR2251B	Rotor locating bolt M6 x 25
14	FN0581	Rotor locating washer M6
15	MRA0249A	Roller assembly (element pumphead)
15	MRA0250A	Roller assembly (continuous pumphead)
16	XX0220	Key - metal
17	MR2055M	Rotor cover
18	MR2029T	Cased drive MG605 shaft/rotor hub spacer
19	TT0006	5mm Allen key
20	FN0488	Cased drive track locating screws M6x10
20	FN0523	Close-coupled track locating screws M6x20

28 620RE, 620RE4 and 620R performance data

Pumping conditions

All performance figures in this operating instruction have been recorded against peak pipeline pressures.

This pump is rated to 4 bar (58psi) peak pressure when fitted with a 620RE, 620RE4 or 620LG pumphead using high-pressure tubing. However, it will generate in excess of 4 bar (58psi) peak pressure if the pipeline is restricted. Where it is important that 4 bar (58psi) is not exceeded, pressure relief valves should be installed in the pipeline.

Viscosity handling is maximised by using 4.0mm wall LoadSure elements with the 620RE and 620RE4 pumpheads.

Flow rates are normalised test values obtained using new tubing with the pumphead rotating clockwise pumping water at 20C with negligible inlet and discharge pressures. Actual flow rates achieved may vary because of changes in temperature, viscosity, inlet and discharge pressures, system configuration and tubing performance against time. Flow rates may also vary due to normal manufacturing tolerances of the tubing. These tolerances will make flow rate variance more pronounced at smaller bore sizes.

For precise and repeatable performance it is important to determine flow rates under operating conditions for each new piece of tubing.

620R and 620L family pumpheads' flow rates are directly proportional to rotor speed. If you wish to run the pump at a speed not shown in the tables below, flow figures can be reached by dividing the maximum flow shown in the tables below by the maximum rpm figure, and multiplying the result by your required speed in rpm.

In normal circumstances, rotor and tube life are maximised if the pumphead is run slowly, particularly when pumping at high pressure. However, to maintain performance at pressures above 2 bar, avoid running the pumphead below 50rpm. If low-flow, high-pressure operation is necessary, switching to a smaller tube is recommended.

STA-PURE Series PFL, STA-PURE Series PCS and Marprene TM tubing are hard to compress when new. When using tubing made of these materials, the first five pumphead revolutions should be at a speed of 10rpm or greater. If the pump is run slower, the safety system built into pump drive's software may cause it to stop and display an over-current error message.

Note: Flow rates quoted have been rounded for simplicity, but are accurate to within 5% - well within the normal tubing tolerance variation of flow rate. They should therefore be taken as a guide. Real flow rates in any application must be determined empirically.

28.1 620RE, 620RE4 and 620R flow rates

Metric (SI)

620 STA-PURE Series PFL, STA-PURE Series PCS, l/min								
	620R				620RE		620RE4	
Speed rpm	6.4 mm	9.6 mm	12.7 mm	15.9 mm	12.0 mm	17.0 mm	12.0 mm	17.0 mm
0.1	0.001	0.003	0.004	0.01	0.004	0.01	0.003	0.01
265	3.2	6.6	11	16	11	18	9.0	13

620 Marprene TL, Bioprene TL, l/min								
	620R (standard)				620RE (standard)		620RE4 (standard)	
Speed rpm	6.4 mm	9.6 mm	12.7 mm	15.9 mm	12.0 mm	17.0 mm	12.0 mm	17.0 mm
0.1	0.001	0.003	0.004	0.01	0.004	0.01	0.003	0.005
265	3.4	6.6	11	12	9.8	18	8.3	12

620 Marprene TM, Bioprene TM, l/min				
	620RE (hard)		620RE4 (hard)	
Speed rpm	12.0 mm	17.0 mm	12.0 mm	17.0 mm
0.1	0.004	0.01	0.003	0.004
265	9.8	16	8.3	11

620 Pumpsil, l/min								
	620R				620RE		620RE4	
Speed rpm	6.4 mm	9.6 mm	12.7 mm	15.9 mm	12.0 mm	17.0 mm	12.0 mm	17.0 mm
0.1	0.001	0.003	0.004	0.01	0.004	0.01	0.003	0.004
265	3.2	7.2	11	15	10	16	8.7	11

US (imperial)

620 STA-PURE Series PFL, STA-PURE Series PCS, USGPM								
	620R				620RE		620RE4	
Speed rpm	6.4 mm	9.6 mm	12.7 mm	15.9 mm	12.0 mm	17.0 mm	12.0 mm	17.0 mm
0.1	0.0003	0.001	0.001	0.002	0.001	0.002	0.001	0.001
265	0.8	1.8	2.8	4.3	2.8	5.1	2.4	3.5

620 Marprene TL, Bioprene TL, USGPM								
	620R (standard)				620RE (standard)		620RE4 (standard)	
Speed rpm	6.4 mm	9.6 mm	12.7 mm	15.9 mm	12.0 mm	17.0 mm	12.0 mm	17.0 mm
0.1	0.0003	0.001	0.001	0.002	0.001	0.002	0.001	0.001
265	0.9	1.8	2.8	3.0	2.6	4.7	2.2	3.3

620 Marprene TM, Bioprene TM, USGPM				
	620RE (hard)		620RE4 (hard)	
Speed rpm	12.0 mm	17.0 mm	12.0 mm	17.0 mm
0.1	0.001	0.002	0.001	0.001
265	2.6	4.1	2.2	2.9

620 Pumpsil, USGPM								
	620R				620RE		620RE4	
Speed rpm	6.4 mm	9.6 mm	12.7 mm	15.9 mm	12.0 mm	17.0 mm	12.0 mm	17.0 mm
0.1	0.0003	0.001	0.001	0.001	0.001	0.002	0.001	0.001
265	0.8	1.9	2.9	3.9	2.7	4.3	2.3	3.0

29 Continuous tubing product codes (620R)

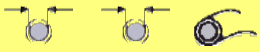
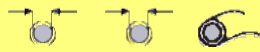
					
mm	inch	#	Marprene	Bioprene	Pumpsil
6.4	1/4	26	902.0064.032	933.0064.032	913.0064.032
9.6	3/8	73	902.0096.032	933.0096.032	913.0096.032
12.7	1/2	82	902.0127.032	933.0127.032	913.0127.032
15.9	5/8	184	902.0159.032	933.0159.032	913.0159.032
					
mm	inch	#	STA-PURE series PFL	STA-PURE series PCS	
6.4	1/4	26	966.E064.K24	961.E064.K24	
9.6	3/8	73	966.E096.K24	961.E096.K24	
12.7	1/2	82	966.E127.K24	961.E127.K24	
15.9	5/8	184	966.E159.K24	961.E159.K24	

30 LoadSure tube element product codes (620RE and 620RE4)

	12mm Tri-clamp 3/4in	17mm Tri-clamp 3/4in	12mm Cam and Groove 3/4in	17mm Cam and Groove 3/4in
STA-PURE series PFL	966.T120.SST	966.T170.SST		
STA-PURE series PCS	961.0120.PFT 966.T120.SST	961.0170.PFT 966.T170.SST		
Bioprene TM	933.P120.PFT	933.P170.PFT		
Bioprene TL	933.0120.PFT	933.0170.PFT		
Pumpsil	913.0120.PFT	913.0170.PFT		
Marprene TM			902.P120.PPC	902.P170.PPC
Marprene TL			902.0120.PPC	902.0170.PPC

Note: = for 4 bar use

31 620L and 620LG pumpheads

The twin offset track design of the 620L utilises 4.0mm wall double-Y tube elements to overcome pulsation for accurate dosing and dispensing. The 620L accepts Silicone and Marprene tubing up to 16.0mm bore.

Alternatively the 620L will run with two separate 4mm-wall tubes although some channel-to-channel variance and minimal pulsation may be experienced. For separate tube fitting or twin tube inlet to single tube outlet fitting tube clamping blocks must be used. See 31.8 620L pumphead spares.

31.1 620L and 620LG key safety information



Before opening the pumphead guard please ensure that the following safety directions are followed.

- Ensure that the pump is isolated from mains voltage.
- Ensure that there is no pressure in the pipeline.
- If a tube failure has occurred, ensure that any product in the pumphead has been allowed to drain.
- Ensure that protective clothing and eye protection are worn if hazardous products are being pumped.

31.2 620L and 620LG Guarding

- Primary safety on 620 series pumps is provided by the tool-lockable pumphead guard—in the case of the 620L and 620LG heads, the tool-lockable pumphead track functions as the guard. Secondary (backup) protection is provided in the form of an electrical guard switch which stops the pump if either end of the track is opened. The electrical guard switch on cased pumps should never be used as primary protection. Always disconnect the mains power supply to the pump before opening the pumphead.

31.3 620L and 620LG pumping conditions

Pressure and viscosity



Always isolate the pump from the mains power supply before opening the guard or performing any positioning, removal or maintenance.

- All pressure values in this operating instruction, from which performance and life figures have been calculated, relate to peak pipeline pressures.
- Although rated to 4 bar peak pressure, the 620LG may generate in excess of 4 bar working pressure if pipeline restrictions are in place. In instances where it is critical that a working pressure of 4 bar is not exceeded, pressure relief valves should be installed in the pipeline.

620L	0-2 bar	Y element or continuous tubing
620LG	0-4 bar	STA-PURE Series PFL and STA-PURE Series PCS Y elements only

- Ensure that there is always a minimum of one metre of smooth bore flexible tubing connected to the discharge port of the pumphead. This will help minimise any impulse losses and pulsation in the pipeline. This is especially important with viscous fluids and rigid pipework.

31.4 620L and 620LG removal and installation

A 620 pump supplied with a 620L pumphead is not intended for use with any other pumphead. However, the pumphead can be removed for cleaning or maintenance.



Always isolate the pump from the mains power supply before opening the guard or performing any positioning, removal or maintenance.



To remove the 620L pumphead

- To remove the pumphead you must first remove the track. The track is secured to the pumphead by cams positioned at its left and right. Where the cam shafts are visible at the front of the pumphead, they are milled square to accept a spanner. Use the 10mm or 3/8in AF spanner provided to rotate the right-hand cam shaft through 180 degrees counter-clockwise, and the left-hand camshaft through 180 degrees clockwise. The position of the cam rotation stops indicate when they are fully closed (third picture, left) and open (right). Lift off the track.
- The pumphead is secured to the black adaptor plate by two M6 screws. Use a 5mm Allen key to remove them. Lift off the pumphead.

It is not normally necessary to remove the adaptor plate. However, if it must be removed for cleaning:

- The adaptor plate is secured to the drive by four M6 screws. Use a suitable screwdriver to remove them. Lift off the adaptor plate. After cleaning, reposition and secure it in the same way.

To install the 620L pumphead

- Clean and grease the projecting dog of the drive shaft. Position the cleaned pumphead so that it engages with the drive-shaft dog. Use two M6 screws to secure the pumphead to the adaptor plate.
- Reverse the directions above to reposition the track.

31.5 620L and 620LG Tube loading

Double-Y elements for low-pulsation flow and dispensing applications

- See illustrations at 31.4 620L removal and installation. The track is secured to the pumphead by cams positioned at its left and right. Where the cam shafts are visible at the front of the pumphead, they are milled square to accept a spanner. Use a 10mm or 3/8in AF spanner to rotate the right-hand cam shaft through 180 degrees counter-clockwise, and the left-hand camshaft through 180 degrees clockwise. The position of the cam rotation stops indicate when they are fully closed (third picture, left) and open (right). Lift off the track.



- Locate one end of double-Y element over one of the 625L clamping pegs. Stretch the element over the rotor and locate the other end of the element over the second 625L clamping peg. Replace the track as described at 33.4 620L removal and installation.

Twin inlet tubes for best handling of viscous fluids

- See illustrations at 31.4 620L removal and installation. The track is secured to the pumphead by cams positioned at its left and right. Where the cam shafts are visible at the front of the pumphead, they are milled square to accept a spanner. Use a 10mm or 3/8in AF spanner to rotate the right-hand cam shaft through 180 degrees counter-clockwise, and the left-hand camshaft through 180 degrees clockwise. The position of the cam rotation stops indicate when they are fully closed (third picture, left) and open (right). Lift off the track.

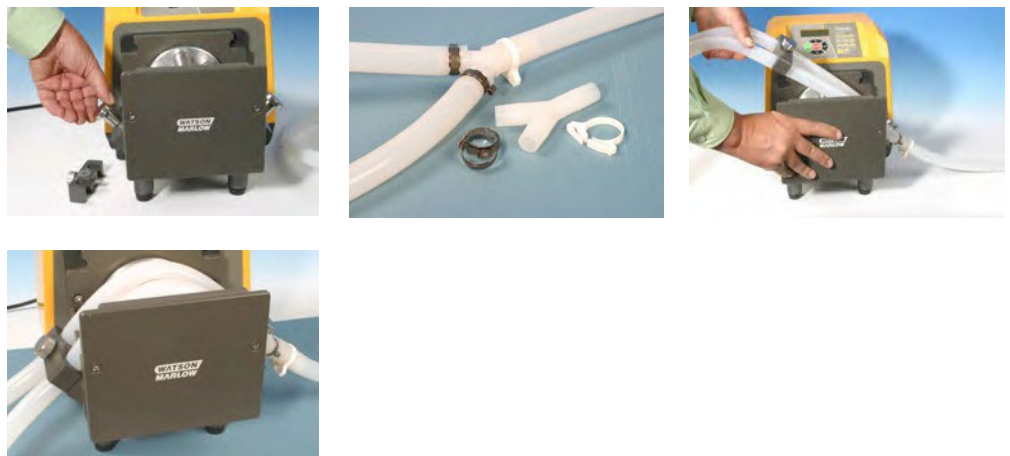

- Unscrew and remove the 625L inlet clamping peg. Connect the twin inlet tubes and outlet tube using the appropriate Y-piece connector and clips. Fit the inlet tubes into the correct size clamping block. Locate the Y-piece end of the ele-

ment over the 625L clamping peg. Stretch the tubes and screw the clamping block into place. Replace the track as described at 31.4 620L removal and installation.

Two independent tubes for twin-channel pumping

- See illustrations at 31.4 620L removal and installation. The track is secured to the pumphead by cams positioned at its left and right. Where the cam shafts are visible at the front of the pumphead, they are milled square to accept a spanner. Use a 10mm or 3/8in AF spanner to rotate the right-hand cam shaft through 180 degrees counter-clockwise, and the left-hand camshaft through 180 degrees clockwise. The position of the cam rotation stops indicate when they are fully closed (third picture, left) and open (right). Lift off the track.

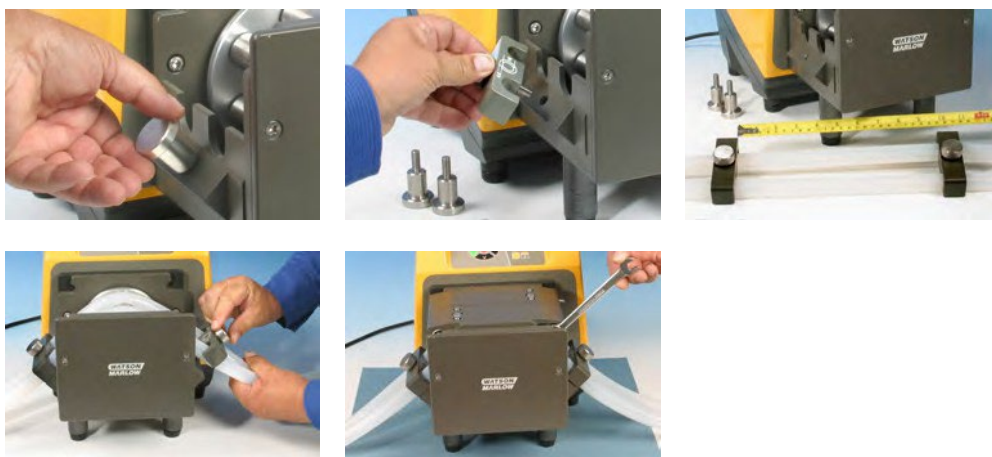

- Unscrew and remove the 625L clamping pegs. Clamping blocks will be used to secure the continuous tube, using the same screw sockets. Fit the two tubes into the correct size clamping blocks. Distance between blocks = 230mm for up to 8.0mm bore; 240mm for 12.0mm and 16.0mm bore. Fit the inlet tube clamping block to the 625L. Stretch the tubes over the rotor and fit the second tube clamping block to the 625L. Replace the track as described at 33.4 620L removal and installation. When using Marprene it is important to check the tube length after 30 minutes running time.

31.6 620L and 620LG care and maintenance

Check all moving parts for freedom of movement occasionally. If aggressive fluids are spilt onto the pumphead, clean using a mild detergent only.

31.7 620L and 620LG track adjustment

The track is set for 4.0mm wall tubing up to 16.0mm bore. Alteration of this setting using the pan head screws may be necessary to optimise performance if non-standard tubing is used. **However, the pump warranty will be invalidated if this is done.** The factory setting is 20.3mm vertically from the rotor side of the sprung track to the top of the track cover.

31.8 620L and 620LG Pumphead spares

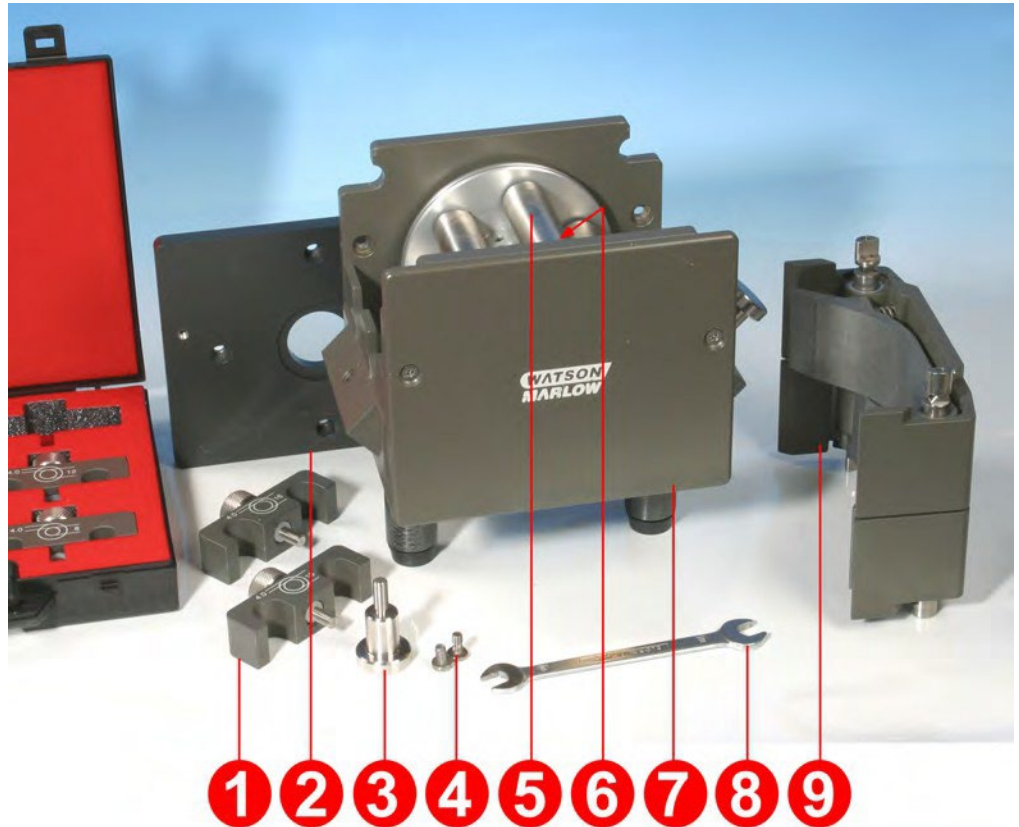

Number	Spare	Description
	MRA3021A	620L pumphead
	MRA3022A	620LG pumphead
1	069.4001.000	Tube clamp set
2	MR3017S	Adaptor plate
3	MRA0144A	Tube locating peg
4	FN0493	M6x12 screws x 6
5	MRA0150A	Rotor assembly
6	BB0018	Shaft bearing
7	MR0850S	Front plate
8	TT0005	10mm / 3/8in spanner
9	MRA3026A	Track assembly
	MR3002	Foot

32 620L and 620LG performance data

STA-PURE Series PFL, STA-PURE Series PCS and Marprene™ tubing are hard to compress when new. When using tubing made of these materials, the first five pumphead revolutions should be at a speed of 10rpm or greater. If the pump is run slower, the safety system built into pump drive's software may cause it to stop and display an over-current error message.

32.1 620L and 620LG flow rates

Note: Rates apply to Y elements and two channels of continuous tubing combined.

620L flow rates (2 bar pressure capacity)

620L, Marprene, Bioprene, l/min				620L, Marprene, Bioprene, USGPM			
Speed rpm	Tube bore (4.0mm wall)			Speed rpm	Tube bore (4.0mm wall)		
	8.0mm	12.0mm	16.0mm		8.0mm	12.0mm	16.0mm
0.1	0.002	0.003	0.004	0.1	0.0004	0.0008	0.0011
265	4.5	8.0	11.3	265	1.18	2.12	2.98

620L, Pumpsil, l/min				620L, Pumpsil, USGPM			
Speed rpm	Tube bore (4.0mm wall)			Speed rpm	Tube bore (4.0mm wall)		
	8.0mm	12.0mm	16.0mm		8.0mm	12.0mm	16.0mm
0.1	0.002	0.003	0.004	0.1	0.0004	0.0008	0.0011
265	4.4	8.5	11.5	265	1.17	2.25	3.05

620LG flow rates (4 bar pressure capacity)

620L, STA-PURE Series PFL, STA-PURE Series PCS, l/min				620L, STA-PURE Series PFL, STA-PURE Series PCS, USGPM			
Speed rpm	Tube bore (4.0mm wall)			Speed rpm	Tube bore (4.0mm wall)		
	8.0mm	12.0mm	16.0mm		8.0mm	12.0mm	16.0mm
0.1	0.002	0.003	0.005	0.1	0.0005	0.0009	0.0012
165	3.1	5.7	7.8	165	0.81	1.52	2.05
265	5.2	9.0	12.4	265	1.39	2.38	3.28

32.2 620L tubing codes

Marprene		Dispensing information	
		Bore	Litres/rev
902.E080.K40	Y element	8.0mm	0.017
902.E120.K40		12.0mm	0.030
902.E160.K40		16.0mm	0.043
902.0080.040	Continuous	8.0mm	0.017
902.0120.040		12.0mm	0.030
902.0160.040		16.0mm	0.043

Bioprene		Dispensing information	
		Bore	Litres/rev
933.E080.K40	Y element	8.0mm	0.017
933.E120.K40		12.0mm	0.030
933.E160.K40		16.0mm	0.043
933.0080.040	Continuous	8.0mm	0.017
933.0120.040		12.0mm	0.030
933.0160.040		16.0mm	0.043

Pumpsil		Dispensing information	
		Bore	Litres/rev
913.AE80.K40	Y element	8.0mm	0.017
913.A12E.K40		12.0mm	0.032
913.A16E.K40		16.0mm	0.044
913.A080.040	Continuous	8.0mm	0.017
913.A120.040		12.0mm	0.032
913.A160.040		16.0mm	0.044

32.3 620LG element codes

STA-PURE Series PCS		Dispensing information	
		Bore	Litres/rev
961.E080.K40	Y element	8.0mm	0.020
961.E120.K40		12.0mm	0.033
961.E160.K40		16.0mm	0.047

STA-PURE Series PFL		Dispensing information	
		Bore	Litres/rev
966.E080.K40	Y element	8.0mm	0.020
966.E120.K40		12.0mm	0.033

DiN, Di

33 620 series pumping accessories

Accessory	Description	Part code	Pump compatibility
520AF	Footswitch with 25-pin D-connector	059.3002.000	620U, 620Du, 620Di
624AF	Footswitch, bare lead	069.5231.000	620UN, 620DuN, 620DiN
520AH	Handswitch with 25-pin D-connector	059.3022.000	620U, 620Du, 620Di
520ANC	Network cable, RS232, with 9-pin D-connectors	059.3121.000	620Du, 620Di
520ANA	Network adaptor, 25-pin to 9-pin D-connector	059.3123.000	
520AB	Batch records cable with 9-pin D-connectors	059.3125.000	620Di
624AV	Proximity switch for 624AS filling stand	069.5271.000	620UN, 620DuN, 620DiN
624AS	Stainless steel filling stand for 624AFN filling needles	069.5001.000	All models
624AFN	Filling needle set (3 sizes)	069.5101.000	All models
	Filling needle for 8.0mm bore tubing	069.5100.080	All models
	Filling needle for 12.0mm bore tubing	069.5100.120	All models
	Filling needle for 16.0mm bore tubing	069.5100.160	All models
624AL	Dispensing lance for use with 624AFN filling needles	069.5251.000	All models
	Tube monitor with 25-pin D-connector	059.4501.520	620U, 620Du, 620Di
	Tube monitor, bare lead	059.450N.520	620UN, 620DuN, 620DiN
620AL	Leak detector kit, bare lead	069.7131.000	620UN, 620DuN, 620DiN

DiN, Di

34 Trademarks

Watson-Marlow, Bioprene, Pumpsil and Marprene are trademarks of Watson-Marlow Limited. Tygon is a trademark of the Saint Gobain Performance Plastics Company.

Fluorel is a trademark of 3M.

GORE® STA-PURE Series PFL, GORE® STA-PURE Series PCS are trademarks of W.L.Gore and Associates.

DiN, Di

35 Warning not to use pumps in patient-connected applications

Warning: These products are not designed for use in, and should not be used for patient-connected applications.

DiN, Di

36 Publication history

m-620din-di-gb-05.docx: Flexicon 620Di, 620DiN

First published 10 05. Revised 01 08. Revised 04 13. Revised 04 13. Revised 08 25

37 Decontamination certificate

In compliance with the UK Health and Safety at Work Act and the Control of Substances Hazardous to Health Regulations, you are required to declare the substances which have been in contact with product(s) you return to Watson-Marlow Ltd or its subsidiaries or distributors. Failure to do so will cause delays. Please ensure that you fax us this form and receive an RGA (Returned Goods Authorisation) before you despatch the product(s). A copy of this form must be attached to the outside of the packaging containing the product(s). Please complete a separate decontamination certificate for each product. You are responsible for cleaning and decontaminating the product(s) before return.

Your name	<input type="text"/>	Company	<input type="text"/>
Address	<input type="text"/>		
Postcode/zip	<input type="text"/>	Country	<input type="text"/>
Telephone	<input type="text"/>	Fax	<input type="text"/>
Product type	<input type="text"/>	Serial number	<input type="text"/>
To speed the repair, please describe all known faults	<input type="text"/>		
The product has ...	<input type="checkbox"/> Been used <input type="checkbox"/> Not been used		
	<i>If the product has been used, please complete all the following sections. If the product has not been used, please just sign this form.</i>		
Names of chemicals handled with product(s)	<input type="text"/>		
Precautions to be taken in handling these chemicals	<input type="text"/>		
Action to be taken in the event of human contact	<input type="text"/>		
	<i>I understand that the personal data collected will be kept confidentially in accordance with the UK Data Protection Act 1998.</i>		
Signature	<input type="text"/>	RGA number	<input type="text"/>
		Your position	<input type="text"/>
		Date	<input type="text"/>
<i>Please print out, sign and fax to Watson-Marlow Ltd at +44 1326 376009.</i>			