

**WATSON  
MARLOW**

Fluid  
Technology  
Solutions



**certa**  
*Plus*

Advancing pharmaceutical  
fluid handling



**masosine**  
Process Pumps



Drawing on considerable experience in sinusoidal pumping technology, Certa Plus has been developed by MasoSine to meet a broad range of applications for the pharmaceutical industry. These include:

## Applications



**Suppositories** – Superior handling capability from high and low viscosity supports more efficient processing



**Syrup and sugar solutions** – Continuous pumping action improves the circulation process when thickening the final product. Seal-flush options are available to prevent sugar-based products drying out



**Creams and gels** – Strong suction capability moves high viscosity products from the mixing tank/reactor to the filling line with ease



**Lozenge** – Energy efficient pumping action even tackles high viscosity pastille products. Available jacketing option prevents the product from hardening within the pump if it's stopped

## Advantages

- High suction capability to handle viscous fluids
- Low shear, zero pulsation and self-draining
- Uses up to 50% less power than lobe and circumferential piston pump types
- Easy to clean pump design certified with:
  - EHEDG Type EL Class I
  - EHEDG Type EL Aseptic Class I
- Exposed fluid contact materials made of Stainless steel 1.4435 material with electro-polished surface
- All fluid contact materials meet the latest FDA and USP Class VI requirements

## Sine<sup>®</sup> pump design

A single sinusoidal rotor creates four evenly sized chambers. As each chamber rotates it gently conveys the fluid from the inlet port to the outlet port. At the same time, the opposite chamber opens to draw in more fluid resulting in a smooth flow with virtually no pulsation.

A gate stops fluid flow from the higher pressure outlet to the low pressure inlet.



## Sine pump advantage

*Low shear and zero pulsation* – ultra low shear pumping with no loss to valuable product integrity

*Superior viscous handling* – powerful suction up to 0.85 bar / 12 PSI vacuum. Products with viscosities from 1 cP to 8 million cP can be transferred with ease.

*Simplicity* – minimal downtime. One shaft, one seal and no timing gears allows maintenance through the front cover keeping the pump connected to the pipes.

*Interchangeable parts* – fully interchangeable components between pumps of the same size, reducing spares

# Advancing pharmaceutical fluid handling

## Cleaner than any lobe or circumferential piston pump

- EHEDG Type EL Class I and EHEDG Type EL I Aseptic Class I
- Type EL Aseptic Class I certification that Certa Plus carries applies to closed equipment, wet clean-in-place (CIP) without dismantling. It is steam sterilisable and bacteria tight. All components are made of FDA and USP Class VI certified raw materials
- Removes the risk of residuals after CIP cleaning due to sanitary design
- Reduces the amount of cleaning chemicals used, and cuts the required cleaning cycle time to a minimum
- Modular seal system options:
  - Single mechanical seal
  - Single mechanical seal with flush
  - Double mechanical seal (which can be used with, and without an overpressure system)

## Virtually pulsation free

- Smooth product flow with no need for ancillary dampeners, ensuring product quality
- Improves flow meter accuracy and heat exchanger efficiency

## Lowest cost of ownership

- Extremely simple maintenance performed in-place by operative
- Patented design allows bi-directional running to pump duty fluid back to source
- Certa Plus can be included in aseptic processes without the need of additional steam ports due to bacteria tight design proven by EHEDG Type EL Aseptic Class I



## Energy efficiency

- Requires up to 50% less power than lobe or circumferential piston pumps
- Greatly reduced electricity use means reduced carbon footprint
- Higher efficiency at high viscosity increases energy savings in your most difficult applications

## Low shear handling for particulates and soft solids

- Improves batch consistency and final product quality
- Low shear action reduces the temperature increase of the pumped liquid to a minimum which is important when circulating products

A space between wet end (pumphead) and power end (bearing housing) of the pump, ensures fluid drains away in the event of a seal failure and eliminates the risk of contamination.



## Sustainability curves

MasoSine Energy Efficiency (Mee) curves demonstrate how the sine principle requires less power to operate in viscous applications. The curves demonstrate clearly how MasoSine pumps help organisations achieve greater sustainability.



# 50%

Certa Plus uses up to 50% less power than lobe and circumferential piston pump types

## Applications

### Unloading – powerful, flexible, easy-to-clean

Certa Plus pumps have powerful suction capabilities. Their ability to prime even high viscosity products without running into cavitation makes them ideal for quick unloading applications, without causing damage to a system.

### Transfer and circulation – hygienic, gentle, adaptable

Certa Plus is fully CIP proven to EHEDG and 3A standards, to avoid any potential product contamination caused by residuals after the cleaning process. The sinusoidal wave rotor design helps to gently transfer valuable pharmaceutical products with minimal shear to prevent product damage.

The pumps can be equipped with pump jacketing to maintain process and product temperature, making Certa Plus adaptable for a range of different circulation applications.

### Versatile – robust fluid handling, rapid product change over

Across applications, varying temperatures result in varying viscosities. For example, in the production of **suppositories**, pumping at lower temperature means an increasing viscosity of the product.

With a seal flush Certa Plus is capable of transferring and handling challenging products from **syrops** and **sugar** solutions to **lozenge products**.

### Meeting the future with up-to-date validation documentation

Certa Plus is rigorously tested to comply with the most up-to-date regulations required.

## Options and accessories

### Connection ports

Certa Plus pumps are available with all standard ports to match your application including DIN, Tri-clamp TC, RJT, and SMS. Customised options are available upon request.

### Port orientations

Pumps can be configured with ports in a range of orientations to meet installation requirements, including a self-draining orientation.

### Accessories

A static and dynamic flush system is available to clean the area behind the seal system. This is even possible with a single mechanical seal.

A jacketing system is available to allow pumps to be heated to the optimal temperature for your process.





## Performance curves

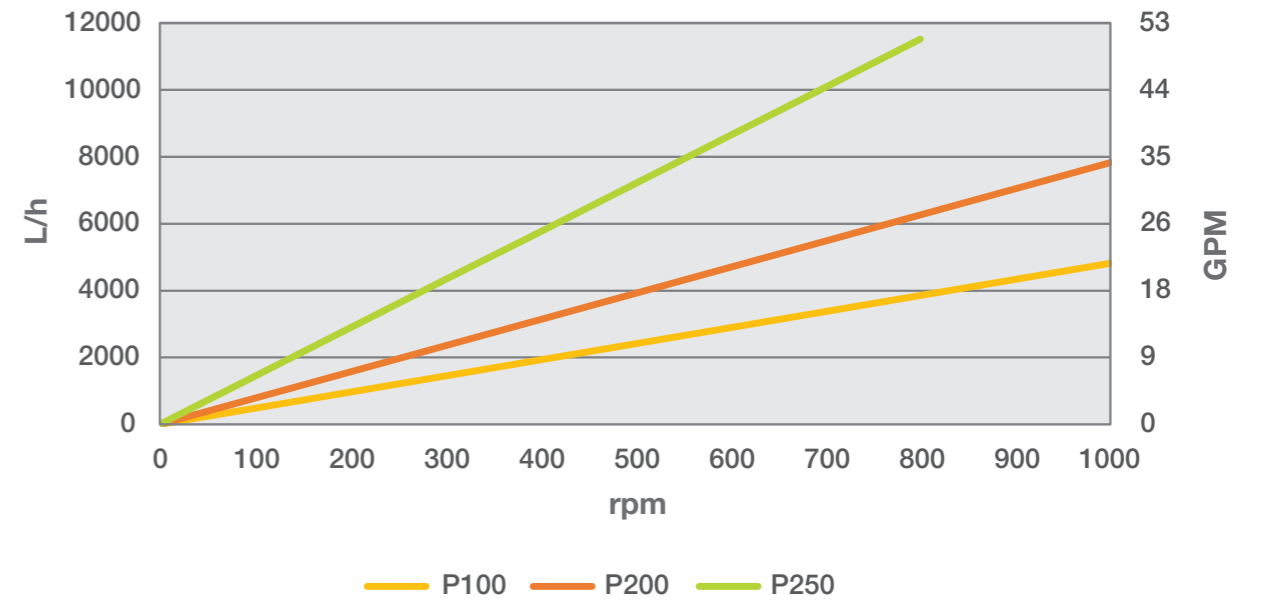

## Customer support

A network providing comprehensive support globally

- Customer response centre
- Global component and system solutions
- Local technical field support

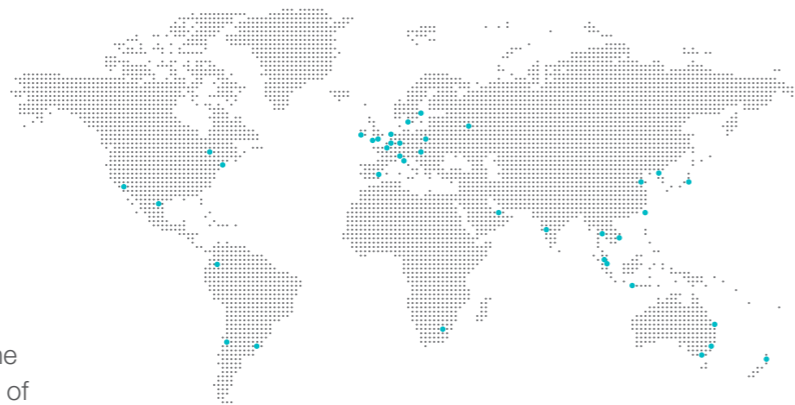

### Genuine spares

MasoSine's approved parts policy means that only the highest quality materials are used in the manufacture of our pumps. This gives our customers confidence that our pumps will not let them down.

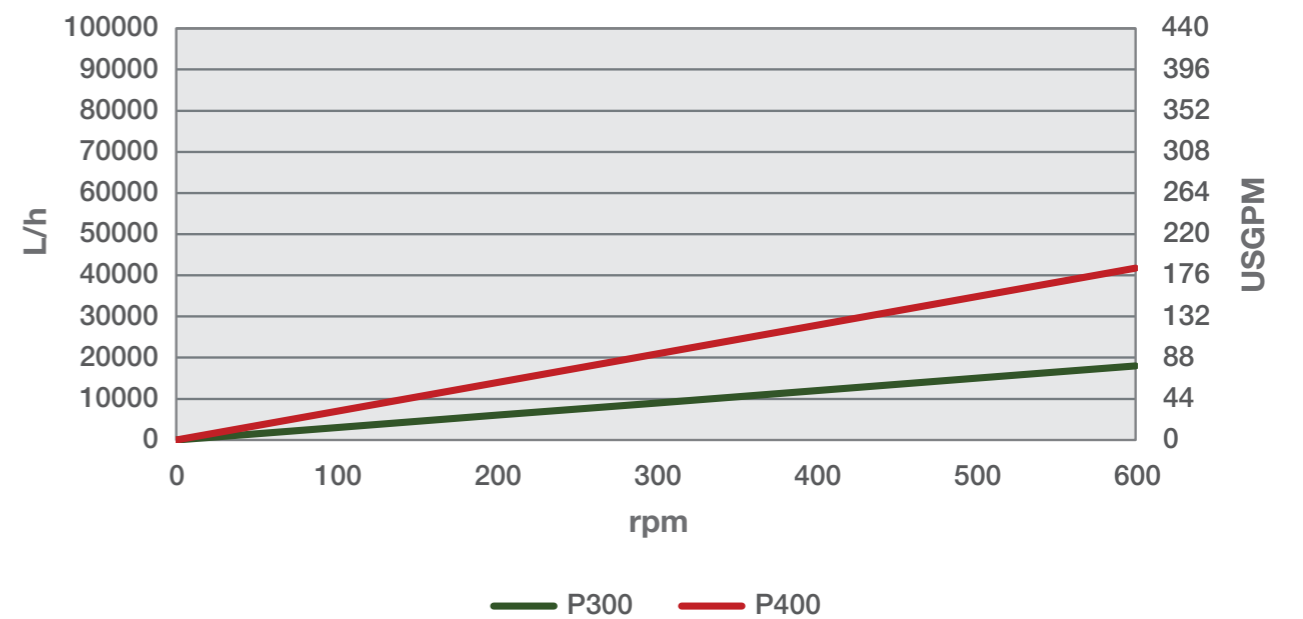



## Dimensions

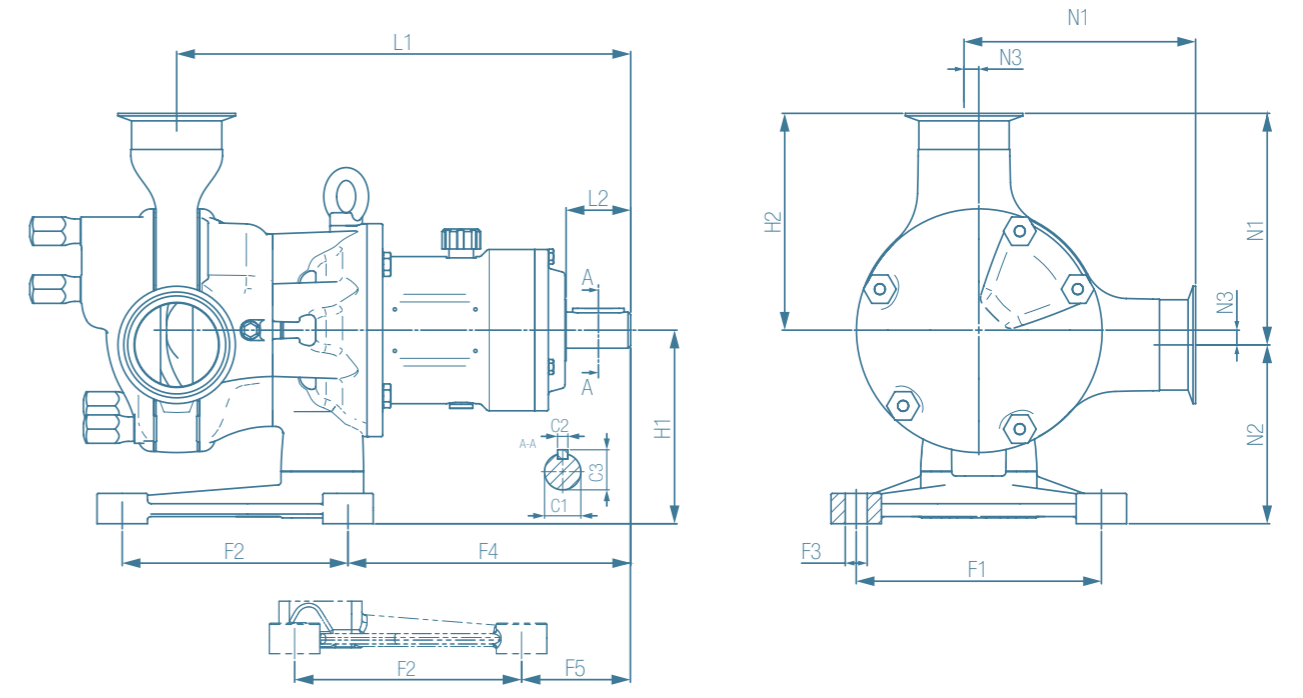

Model	Nozzles			Foot					Length		Height		Coupling		
	N1	N2	N3	F1	F2	F3	F4	F5	L1	L2	H1	H2	C1	C2	C3
	mm	mm	mm	mm	mm	mm	mm	mm	mm	mm	mm	mm	mm	mm	mm
Certa Plus 100	139	85	10	120	135	Ø12	143	57	265	50	95	129	Ø28	8	31
Certa Plus 200	155	99.5	10	120	135	Ø12	168	81.5	299	50	110	145	Ø28	8	31
Certa Plus 250	192	139	12	190	175	Ø17	219	84	352	50	150	180	Ø28	8	31
Certa Plus 300	238	153	18	250	215	Ø20	285	154	456	80	170	220	Ø50	14	54
Certa Plus 400	324	169	31	266.5	254	Ø21	301	169	514	77	200	293	Ø50	14	54

## Technical data

Model	Maximum particle size	Volume per revolution	Maximum Speed	Maximum flow	Maximum pressure	Maximum temperature	Shaft diameter	Shaft height
	mm	litre	rpm	l/h	bar	C	mm	mm
Certa Plus 100	13	0.08	1000	4,800	6 bar	100	28	95
Certa Plus 200	18	0.13	1000	7,800	6 bar	100	28	109.5
Certa Plus 250	22	0.24	800	11,520	6 bar	100	28	146
Certa Plus 300	30	0.50	600	18,000	6 bar	100	45	150
Certa Plus 400	38	1.16	600	41,760	6 bar	100	50	195

BIOTECHNOLOGY AND PHARMACEUTICAL SOLUTIONS



**Watson-Marlow Fluid Technology Solutions**

Watson-Marlow Fluid Technology Solutions supports its customers locally through an extensive global network of direct sales operations and distributors

[wmfts.com/global](http://wmfts.com/global)

